

1949-52 BRAKES



**1949-50 FRONT
BRAKE SHOES**
ORDER #5401

\$45⁰⁰ set

**1949-50 REAR
BRAKE SHOES**
ORDER #5402

\$45⁰⁰ set

BRAKE SHOES

Replace worn shoes with solid new shoes.

**1951-52 FRONT
BRAKE SHOES**
ORDER #1401

\$38⁰⁰ set

**1951-52 REAR
BRAKE SHOES**
ORDER #1402

\$38⁰⁰ set

BRAKE SHOE HOLD DOWN SPRING KIT



Each kit will do 2 wheels.
Need 2 sets per car.

1951-52 KIT
ORDER #1416

\$12⁰⁰ set



1951-52 BRAKE DRUM

New replacement.
Ready to install.
Fits all models.

ORDER #1427

\$67⁰⁰ ea.

BRAKE ADJUSTING HOLE PLUG

2 sets needed for
1949-50 cars.
1 set needed for
1951-52 cars.



ORDER #1429

\$5⁰⁰ set of 4

BRAKE SHOE RETURN SPRINGS



1949-50. Sold in pairs.
Requires 4 springs per car.

ORDER #5403

\$12⁰⁰ pr.



1951-52.
Sold in 4 per package.
Requires 8 per car.

ORDER #1423

\$11 set of 4

BRAKE ADJUSTING SCREW SPRING

Requires 4 per car for 1951-52 models.

ORDER #1430

\$7⁰⁰ ea.



BRAKE ADJUSTOR SCREW

1951-52 models. Sold separately. Requires 4 per car.



ORDER #1421

\$12⁰⁰ ea.

BRAKE BLEEDER SCREW

Requires 4
per car for
1949-52
models.



ORDER
#1447

\$2⁰⁰ ea

BRAKE PEDAL RETURN SPRING

Connects to frame and
brake pedal to return
brake after use.

ORDER #1456 **\$10⁰⁰**



1949-52 BRAKE AND CLUTCH PAD

Replace worn pads with
new pads.
Looks great!

ORDER #4702

\$6⁰⁰ ea.

BRAKE LIGHT SWITCH

Exact reproduction.

1949-50 SWITCH **\$22⁰⁰**
ORDER #5332

1951-52 SWITCH **\$22⁰⁰**
ORDER #1332



1949-52 EMERGENCY BRAKE HANDLE

ORDER #5407
\$28⁰⁰ ea.



1953-54 BRAKE SHOES / BRAKE DRUMS

BRAKES SHOES

Even brake shoes can be a difficult item to find for a forty-year-old car, but we supply top quality shoes for your car.

FRONT BRAKE SHOE SET (Both wheels)
ORDER #1401

\$38⁰⁰

REAR BRAKE SHOE SET (Both wheels)
ORDER #1402

\$38⁰⁰



BRAKE SHOE HOLD DOWN SPRING KIT

ORDER #1416

Sold by the set.
Need 2 sets per car.



\$12⁰⁰ set

BRAKE ADJUSTING SCREW SPRING

Requires 4 per car.

ORDER #1430 **\$7⁰⁰** ea.



BRAKE ADJUSTOR SCREW

Sold separately -
Requires 4 per car.



ORDER #1421
\$12⁰⁰ ea.

BRAKE ADJUSTING HOLE PLUG

Does all 4 wheels.



ORDER #1429
\$5⁰⁰ set of 4

1953-54 POWER BRAKE PEDAL PAD

Exact reproduction. Excellent quality.



ORDER #727
\$22

1953-54 BRAKE AND CLUTCH PAD

Replace worn pads with new pads.
Look great!



ORDER #702
\$6⁰⁰ ea.

CLUTCH AND BRAKE SHAFT SEAL SET

Seals where rods go thru floor.



ORDER #785
\$8⁰⁰ pr.

BRAKE BLEEDER SCREW

Requires 4 per car.



ORDER #1447
\$2 ea.

BRAKE SHOE RETURN SPRINGS

Sold in sets of 4.
Need 8 springs per car.



ORDER #1423
\$11⁰⁰ set of 4

CLUTCH PEDAL STOP RUBBER BUMPER

Mounts on clutch pedal rod to keep clutch pedal from going too far.



ORDER #784 **\$5⁰⁰** ea.

BRAKE DRUM

New replacement.
Ready to install.
Fits Front or Rear



ORDER #1427
\$67⁰⁰ ea.

BRAKE PEDAL RETURN SPRING

Connects to frame and brake pedal to return brake after use.

ORDER #1456 **\$9⁰⁰**



BRAKE LIGHT SWITCH

Just like original!



ORDER #1332 **\$22⁰⁰**

1953-54 CHROME EMERGENCY BRAKE HANDLE

ORDER #726

\$25⁰⁰ ea.



1953-54 EMERGENCY BRAKE HANDLE

Original black bakelite handle.

ORDER #726B



\$34⁰⁰ ea.

1949-52 BRAKE LINES

Don't take chances on old, rusty or bent brake lines. Our brake lines are reproduced with the original contours and fittings and end caps keep lines free of moisture and dust until you are ready to use them. The front lines have steel wrap just like the original. A small price to pay to protect a large investment!

SET 1: Includes front driver side line and front passenger side line
(2 clips required on this line - not included).

1949-50

- ORDER #5412 2- & 4-door sedan, coupe, station wagon, or sedan delivery stainless steel lines..... **\$60⁰⁰** pr.
- ORDER #5414 Hardtop stainless steel lines..... **\$58⁰⁰** pr.
- ORDER #5416 Convertible front stainless steel lines **\$60⁰⁰** pr.

1951-52

- ORDER #1432 2- & 4-door sedan, coupe, station wagon, or sedan delivery stainless steel lines..... **\$60⁰⁰** pr.
- ORDER #1442 Hardtop stainless steel lines..... **\$58⁰⁰** pr.
- ORDER #1434 Convertible front stainless steel lines **\$60⁰⁰** pr.

SET 2: Includes line that goes from master cylinder to passenger side and front to rear brake line (3 clips required on this line - not included)

1949-50

- ORDER #5418 2- & 4-door sedan, coupe, station wagon, or sedan delivery stainless steel lines..... **\$64⁰⁰** pr.
- ORDER #5420 Hardtop stainless steel lines..... **\$64⁰⁰** pr.
- ORDER #5422 Convertible stainless steel lines..... **\$64⁰⁰** pr.

1951-52

- ORDER #1436 2- or 4-door sedan, coupe, station wagon or sedan delivery stainless steel lines **\$62⁰⁰** pr.
- ORDER #1444 Hardtop stainless steel lines..... **\$62⁰⁰** pr.
- ORDER #1438 Convertible stainless steel lines **\$62⁰⁰** pr.

SET 3: Includes driver side rear line - all models, and passenger side rear line - all models.

1949-50

- ORDER #5424 All models stainless steel lines..... **\$42⁰⁰** pr.

1951-52

- ORDER #1440 All models stainless steel lines..... **\$42⁰⁰** pr.



BRAKE LINE PLACEMENT DIAGRAM

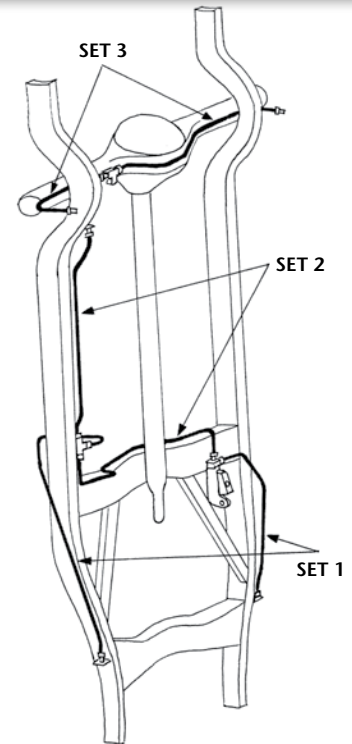

1953-54 BRAKE LINES



Don't take chances on old, rusty or bent brake lines. Our brake lines are reproduced with the original contours and fittings and includes end caps to keep lines free of moisture and dust until you are ready to use them. The front lines have steel wrap, just like the original.



1949-54 BRAKE LINE FRAME CLIP

Sold Separately.
Requires 5 per car

ORDER #1418
\$6⁰⁰ ea.

SET 1: Includes front driver side line and front passenger side line
(2 clips required on this line - **not included**)

- 2- & 4-door sedan, coupe, station wagon, or sedan delivery stainless steel lines ORDER #1432 **\$60.00** pr.
- Hardtop stainless steel lines ORDER #1442 **\$58.00** pr.
- Convertible front stainless steel lines ORDER #1434 **\$60.00** pr.

SET 2: Includes line that goes from master cylinder to passenger side and front to rear brake line (3 clips required on this line - **not included**)

- 2- or 4-door sedan, coupe, station wagon or sedan delivery stainless steel lines ORDER #1436 **\$62.00** pr.
- Hardtop stainless steel lines ORDER #1444 **\$62.00** pr.
- Convertible stainless steel lines ORDER #1438 **\$62.00** pr.

SET 3: Includes driver side rear line - all models, and passenger side rear line - all models.

- All models stainless steel lines ORDER #1440 **\$42.00** pr.