

# 1949-52 BRAKE LINES

Don't take chances on old, rusty or bent brake lines. Our brake lines are reproduced with the original contours and fittings and end caps keep lines free of moisture and dust until you are ready to use them. The front lines have steel wrap just like the original. A small price to pay to protect a large investment!

**SET 1:** Includes front driver side line and front passenger side line  
(2 clips required on this line - not included).

**1949-50**

- ORDER #5412 2- & 4-door sedan, coupe, station wagon, or sedan delivery stainless steel lines..... **\$60<sup>00</sup>** pr.
- ORDER #5414 Hardtop stainless steel lines..... **\$58<sup>00</sup>** pr.
- ORDER #5416 Convertible front stainless steel lines ..... **\$60<sup>00</sup>** pr.

**1951-52**

- ORDER #1432 2- & 4-door sedan, coupe, station wagon, or sedan delivery stainless steel lines..... **\$60<sup>00</sup>** pr.
- ORDER #1442 Hardtop stainless steel lines..... **\$58<sup>00</sup>** pr.
- ORDER #1434 Convertible front stainless steel lines ..... **\$60<sup>00</sup>** pr.

**SET 2:** Includes line that goes from master cylinder to passenger side and front to rear brake line (3 clips required on this line - not included)

**1949-50**

- ORDER #5418 2- & 4-door sedan, coupe, station wagon, or sedan delivery stainless steel lines..... **\$64<sup>00</sup>** pr.
- ORDER #5420 Hardtop stainless steel lines..... **\$64<sup>00</sup>** pr.
- ORDER #5422 Convertible stainless steel lines..... **\$64<sup>00</sup>** pr.

**1951-52**

- ORDER #1436 2- or 4-door sedan, coupe, station wagon or sedan delivery stainless steel lines ..... **\$62<sup>00</sup>** pr.
- ORDER #1444 Hardtop stainless steel lines..... **\$62<sup>00</sup>** pr.
- ORDER #1438 Convertible stainless steel lines ..... **\$62<sup>00</sup>** pr.

**SET 3:** Includes driver side rear line - all models, and passenger side rear line - all models.

**1949-50**

- ORDER #5424 All models stainless steel lines..... **\$42<sup>00</sup>** pr.

**1951-52**

- ORDER #1440 All models stainless steel lines..... **\$42<sup>00</sup>** pr.



**BRAKE LINE PLACEMENT DIAGRAM**

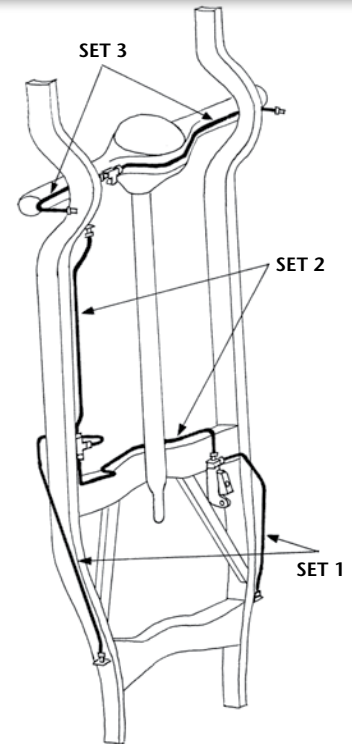

# 1953-54 BRAKE LINES



Don't take chances on old, rusty or bent brake lines. Our brake lines are reproduced with the original contours and fittings and includes end caps to keep lines free of moisture and dust until you are ready to use them. The front lines have steel wrap, just like the original.



**1949-54 BRAKE LINE FRAME CLIP**

Sold Separately.  
Requires 5 per car

ORDER #1418  
**\$6<sup>00</sup>** ea.

**SET 1:** Includes front driver side line and front passenger side line  
(2 clips required on this line - **not included**)

- 2- & 4-door sedan, coupe, station wagon, or sedan delivery stainless steel lines ORDER #1432 **\$60.00** pr.
- Hardtop stainless steel lines ORDER #1442 **\$58.00** pr.
- Convertible front stainless steel lines ORDER #1434 **\$60.00** pr.

**SET 2:** Includes line that goes from master cylinder to passenger side and front to rear brake line (3 clips required on this line - **not included**)

- 2- or 4-door sedan, coupe, station wagon or sedan delivery stainless steel lines ORDER #1436 **\$62.00** pr.
- Hardtop stainless steel lines ORDER #1444 **\$62.00** pr.
- Convertible stainless steel lines ORDER #1438 **\$62.00** pr.

**SET 3:** Includes driver side rear line - all models, and passenger side rear line - all models.

- All models stainless steel lines ORDER #1440 **\$42.00** pr.