

# *Cruisin'* **THE USA**

*Your #1 Source  
for '49 - '54  
Chevrolet Parts*

**\$8.00**  
**2022 Catalog No. 20**

947 Arcade  
St. Paul, MN 55106  
(651) 778-9522  
Fax 1-800-785-5354  
**www.49-54NCA.com**  
**www.nationalchevyassoc.com**

**GOLFATHAC STRAP VNEC 45/94**



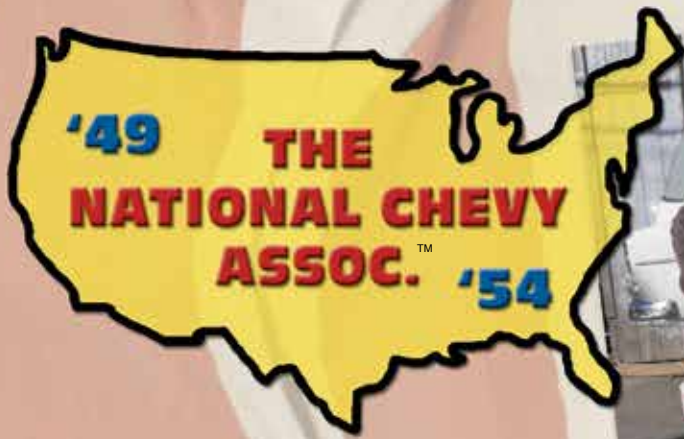

*Thousands of old car clubs are flourishing across America, but few have grown to the size of National Chevy. This success can be attributed mainly to our many loyal members and the popularity of the 1949-54 Chev. The club would not exist today if not for its founding members, Paul and Sharon Nimis, whose idea it was to form a car club dedicated to the Pleasure, Pride and Preservation of the '53 & '54 Chev. The rest is history.*

*Since 1985, the National Chevy Association has been the car club of choice for owners of Chevrolet's "Forgotten Classics." A few years back, the 49-52 Chevs were added to the Association base and growth continues as new generations discover that the car the "old man" drove to high school is kinda cool and affordable to own and restore.*

*Members can be found around the world. To keep in touch we publish a monthly newsletter called "Parts-Line." Each issue contains general news, technical help, nostalgia, classified ads, monthly specials, contests and most important, pictures and articles from members about their cars. "Mail Order Swap Meets" are a unique way we found to sell hard-to-find parts.*

*The success of the Association is based on the strength of its members. The newsletter is made up almost entirely of articles and cars sent in by members. We love cars! Cars are the reason we are all here — restorations, customs, daily drivers, long-term projects or anywhere in between. We are glad you are here to share our love of cars!*

*If you happen to be passing through Minnesota, stop in for a visit (bring your car). To find out a little more about our Association, visit us on the web at*

**[www.49-54nca.com](http://www.49-54nca.com)**



# MONTHLY ONLINE NEWSLETTER

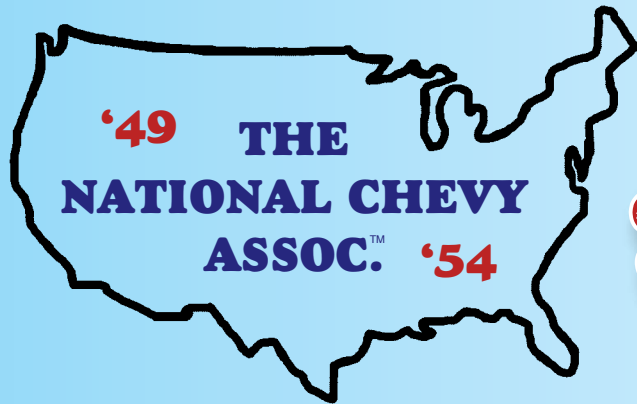

*Let the fun begin!*

*You don't want to miss a single issue of the "Parts-Line"!*

To our loyal members we are proud to have over the last 30 years offered you a high quality mailed monthly newsletter packed with great deals, super buys, members car builds and tech tips. We thank you for your years of support! But alas just like the times, we are changing and growing.

We will now offer the same great monthly newsletter free to everyone on our website! You will have access to each great monthly issue when ever you want! Catch up on the latest issues on your phone, tablet, computer or print it out! Each issue will still be packed with the same great content as always!

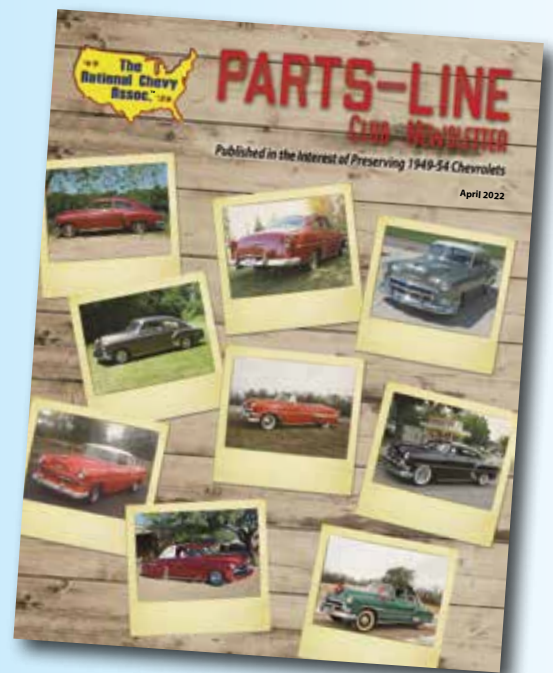

Head over to [www.nationalchevyassoc.com](http://www.nationalchevyassoc.com) and check it out!

*Join us online*  
**FREE**

*Download*  
*for a hard copy!!*



# QUICK INDEX

## INFORMATION

Shipping.....	4
Membership.....	1
Shirts / Hats.....	5
Gift Certificates.....	5
Quick Index.....	2, 3
Alphabetical Index.....	165-168

## LITERATURE

Shop Manual.....	18, 19, 23, 24
Accessory Installation Manuals...	21, 23, 24
Engine Paint and Decals.....	21-27

## TAIL LIGHTS

Lens Gaskets / Lens.....	31, 35
Chrome Tail Light Bezels.....	31, 35
Blue Dot Lens.....	31, 35

## HOOD EMBLEMS & BEZELS

Trunk Emblems and Bezels.....	36
Hood Birds.....	36
Dash / Exterior Script.....	37
Fender Markers.....	38
Fender Gravel Shields.....	38
Hub Caps / Trim Rings.....	38

## STAINLESS MOLDINGS

Fender / Door Moldings.....	42
Rocker Moldings.....	42
Molding Clip Kits.....	42, 47

## CONTINENTAL KITS

Continental Kit.....	12, 13
'53/54 BelAir Bloomers.....	17
Mirrors.....	40, 41
Headlight Covers.....	15
Car Covers.....	16

## INTERIOR PARTS

Headliners / Sunvisors.....	64, 65
Carpets / Windlace.....	65, 68, 69
Door Sill Plates.....	70, 71
Custom Interior Kits.....	76-89
Ignition Parts / Keys.....	164
Radio Parts / Knobs.....	56, 60
Horn Parts / Glove Boxes.....	56-60
Dome Lights / Door Handles.....	62, 63

## TRUNK

Trunk Mats / Carpet.....	98, 99
Cardboard Sets.....	96
Weatherstrip.....	97
Spare Tire Covers.....	97
Trunk Grommets / Tags.....	98, 99

## WIRING

6V to 12V Conversion Kits.....	140
6 Volt Bulbs.....	141
Turn Signal Harness.....	138
Body / Tail Light / Dash / Engine.....	139
Headlight Harness.....	138
Brake Light Switch.....	129, 130
6V Flasher / Dimmer Switch.....	141
Tools.....	163

## GLASS/RUBBER GASKETS

Windshield / Rear Window.....	103, 105
Side Glass - Clear, Tint, Gray.....	102-104
Channel Kits.....	108, 109
Chrome HT/Conv. Glass Frames.....	105
Vent Window Gaskets..	111, 112, 113, 114
Convertible Tops.....	115
Wiper Blades / Arms.....	117
12V Electrical Wiper Motor.....	117
6V/12V Outside Sunvisor.....	115



# QUICK INDEX

## EXHAUST

Stock Exhaust All Models .....	151
Complete Dual Exhaust Kit .....	152
Mufflers / Clamps .....	152, 153
Exhaust Deflectors / Chrome Tips .....	152

## GRILL PARTS/BUMPERS

Bumpers / Bumper Bolts .....	49, 50
Bumper Assembly Kits.....	49, 50
Grill Bars / Corners / Teeth.....	52, 53
Grill Assembly Kits .....	48
Park Light Assemblies / Lens .....	51
Headlight Buckets / Bezels / Bulbs / Grommets / Seals..	141

## FIREWALL/UNDERHOOD

Firewall / Underhood Pads .....	145-146
Body to Frame Pads .....	149
Anti-Squeak Kits.....	149
Radiator Saddle Cushions / Shims .....	135
Assorted Grommets .....	143, 144
Hood Springs / Tools / Bolts .....	148
Battery Tray .....	128

## GAS TANKS/FUEL RELATED

Poly Tanks / Steel Tanks .....	118
Fuel Lines / Sending Units.....	118, 119
Tank Straps / Fuel Pumps.....	118, 120
Stainless Gas Door Guards .....	121
Accelerator Pedal .....	120

## METAL PANELS

Rocker Panels.....	156, 160
Floor Pans / Trunk Panels .....	155
Wheel Opening Panels.....	156, 160
Behind Tire Panels .....	155, 159
Spare Tire Wells .....	154
Fender Skirts.....	55

## DOOR WEATHERSTRIP

Door Grommets .....	93, 94
Outside Door Handles.....	39
Stainless Door Handle Shields .....	39

## BRAKES/WHEEL CYLINDERS

Brake Shoes / Lines .....	129, 130, 131
Master Cylinder .....	133
Brake Drums / Brake Hose.....	129, 133
Emergency Brake Cable / Handle .....	132
Retaining Clips / Rebuild Kits .....	131
Brake Pedal Pads / Springs .....	129, 130

## FRONT/REAR SUSPENSION

Shocks / Leaf Springs .....	143, 144
Tie Rod Ends / King Pin Kits .....	142
Coil Springs / Idler Arm Kit .....	142, 143
Assorted Pins / Bushings .....	142
Lowering Blocks / U Bolts.....	144

## RADIATOR/WATER RELATED

Radiator / Radiator Hose .....	135
Heater Control Valve.....	136
Water Pump / Heater Hose .....	136
Thermostat / Gaskets.....	135
Electric Fan .....	135

## MOTOR/TRANSMISSION

Tune-up Kits / Gaskets .....	125
Vacuum Advance.....	125
Chrome Valve Covers .....	124
Oil Filters / Lines / Caps .....	124
Plug Wires .....	125
Transmission Rebuild Kit .....	127
Clutch Kit / U-Joint Gasket .....	126
Transmission Lines .....	126
Speedometer Cable .....	126
3-Speed Floor Shift Kit .....	127
Rear End Seals / Gaskets.....	122



# ORDERING & SHIPPING INFORMATION

## ORDERING

National Chevy Parts will gladly accept your order by mail, phone or fax. It's also possible to place your order over the internet by visiting our online catalog at [www.49-54nca.com](http://www.49-54nca.com) or [www.nationalchevyassoc.com](http://www.nationalchevyassoc.com).

**MAIL** If possible, please use the order forms enclosed in the catalog. **Complete all necessary information** to insure that your order will be processed as quickly as possible. Use catalog part numbers, provide a description of the item, and specify color, size, etc. when required. (Provide vehicle information to guarantee that we will have all the information we need to fill your order with accuracy.)

**PHONE** Orders are accepted by phone Monday-Friday 8:30-5:00 (central time). We would appreciate it if you would **use catalog part numbers when ordering**, but our courteous sales representatives will aid you in ordering the parts you need however you describe them (651) 778-9522.

**FAX** Use our toll-free fax number in the Continental United States (800) 785-5354. Worldwide fax (651) 778-9686. Provide all the necessary information, as if you were mailing in the order.

**ONLINE ORDERING** [www.49-54NCA.com](http://www.49-54NCA.com) or [www.nationalchevyassoc.com](http://www.nationalchevyassoc.com) All information sent to us over the internet will remain strictly confidential, as our online catalog is hosted by a secure provider.

## METHOD OF PAYMENT

**CREDIT CARD** National Chevy Parts accepts **Visa, MasterCard, American Express** and **Discover**. Mail orders require a cardholder's signature.

**CHECKS OR MONEY ORDERS** Your personal check is welcome.

**C.O.D. ORDERS** A collection charge of \$10.00 will be added to every C.O.D. order. C.O.D. orders are shipped to the Continental United States, Hawaii, and Puerto Rico only. (No C.O.D. shipments to Canada or foreign countries.) Orders shipped C.O.D. with **UPS** will require a certified check or money order or personal check. (UPS no longer accepts cash.) **FedEx** C.O.D. orders will require cash, certified check/money order or personal checks on any C.O.D. orders.

## SHIPPING

All orders are shipped via **UPS** or **FED EX**.

**FASTER DELIVERY** Faster delivery (Continental US only) can be obtained by using **Next Day, Two Day** or **Three Day** shipping. These services cost more than regular ground shipping, but are valuable if you need the part fast. All optional shipping charges are calculated by the combination of **weight of package** and **distance to ship**, therefore it is impossible to calculate exact cost until package is ready to ship. We'd be happy to contact you with exact shipping charges before shipping, if requested.

**FOREIGN COUNTRY SHIPMENTS** All orders to foreign countries must be prepaid in U.S. Funds or charged to a credit card. No C.O.D.'s accepted. Orders to overseas locations can be shipped via Express or Expedited Services. (No ground service available.)

A - Express service usually arrives at location in about 2 days.

B - Expedited Services usually arrives at location in about 4 days. No ground service is available.

**CANADIAN SHIPMENTS** Shipments must be prepaid in U.S. Funds or charged to credit card. No. C.O.D. service is available. All orders will be shipped via UPS Ground Service unless air service is requested. Some mail service is available. UPS now serves all addresses in Canada.

**DAMAGED SHIPMENTS** Please check all parts immediately upon receipt. If an item has been damaged in shipment, call the carrier. UPS (800) 742-5877  
FED EX (800) 448-9961

Keep the package, all packing material, and all of the items together. The carrier will come out to your location and inspect the package and its contents, and will return the damaged item(s) to us. **Then call us** and let us know what was damaged so we can get a replacement part to you.

## SERVICE

**NOT IN STOCK** National Chevy maintains an extensive inventory of parts to provide you with the fastest possible service. Due to the unique nature of our business, certain items periodically outsell our best inventory estimates. We try not to let this happen but when it does we will backorder the part if we think it will be back in stock soon. If it will be a long delay we will instead refund your money on the item. As soon as any item that has been out of stock is back in stock we will send you a postcard.

**INQUIRIES** Please check your order as soon as it is received for errors or shortages. All orders are double checked before shipping but we are human and do make an occasional mistake. If you have a problem please notify us at once. Problems not reported in **one week** from order receipt **will not** be replaced at our expense.

**RETURNS** Any part that is not satisfactory may be returned within **30 days** for a **full refund**. Shipping charges will not be refunded. **ALL RETURNS must be accompanied by a copy of the invoice or item will be sent back to you. All parts must be returned in original package in resalable condition.** If an item is defective or we made an error on your order we will reimburse your return shipping at regular ground rates. (If you order a part shipped by air, you will not be refunded the **extra** shipping cost.) If you return a part because you decided not to use it, you're responsible for the shipping charges. **NO RETURNS AFTER 30 DAYS. NO RETURNS WITHOUT A COPY OF THE INVOICE.** Any returns after 30 days will have serious penalties and must be accompanied by a receipt. **CALL FIRST! 651-778-9522.**

# HATS

Our hats are available in 3 colors. The simple embroidered design looks great!



**Black Hat**  
ORDER #94



**Navy Blue Hat  
Beige Brim**  
ORDER #95

**Beige Hat  
Navy Blue Brim**  
ORDER #96



*Only \$20 ea.*

# SHIRTS

100% cotton pique polo shirt with pocket.

Navy only  
L, XL, XXL

Specify size or we'll send you an XL

**Polo Shirt**

ORDER #20

**\$20<sup>00</sup>**



**SPECIFY SIZE**

**If no size is specified - we'll send you an XL**

Available in L, XL, XXL

Specify size or we'll send you an XL

**Sweatshirt**

ORDER #6

**\$18<sup>00</sup>**

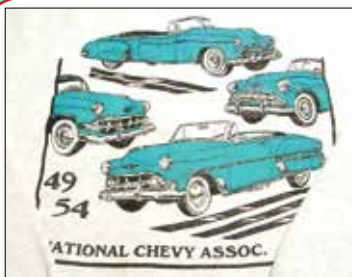

## T-Shirts

Patterned after our best selling "1953-54 National Chevy Association" T-Shirts. These shirts are ash in color with turquoise and black cars and lettering. Printed on top quality shirts. Now you can proudly display your affiliation to the "National Chevy Association," no matter what year of car you own.

All shirts available in S, M, L, XL and XXL. (Specify size or we'll send you an XL!)

*Wear a National Chevy Association T-shirt! A great way to locate and meet fellow members at car shows.*

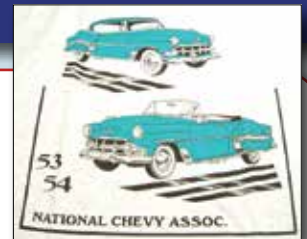

**1953-54 T-shirt**  
ORDER #1



**1949-50 T-shirt**  
ORDER #4001

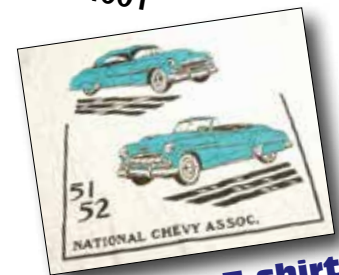

**1951-52 T-shirt**  
ORDER #4002

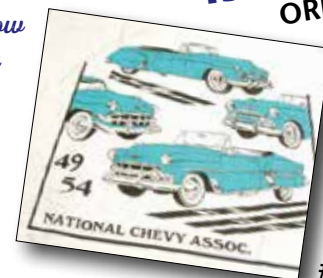

**1949-54 T-shirt**  
ORDER #4003

*Only \$12 Each*

## Give a Gift Certificate

With so many items to choose from you can be sure that special someone will find exactly what he or she needs. Certificates are redeemable by mail or in person at our store.



*New*

**National Chevy T-Shirts**

Newly designed Chevie "Custom" cars T-shirt.

White ORDER #4005

Black ORDER #4006



**\$15 Each**







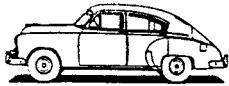

*Specify Size*

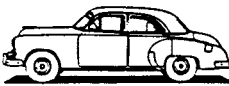

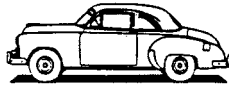
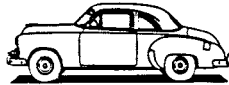

# 1949 MODEL IDENTIFICATION

De Luxe - Series 2100		FLEETLINE		
Vehicle Type	Model	Name and Description	Model	Special - Series 1500 Vehicle Type
	2153 49-1008 *	4-DOOR SEDAN 5-passenger, 5-window sedan with luggage compartment in rear.	1553 49-1208 *	
	2152 49-1007 *	2-DOOR SEDAN 5-passenger, 5-window sedan with luggage compartment in rear.	1552 49-1207 *	

De Luxe - Series 2100		STYLELINE		
Vehicle Type	Model	Name and Description	Model	Special - Series 1500 Vehicle Type
	2103 49-1069 *	4-DOOR SEDAN 6-passenger, 5-window sedan with luggage compartment in rear.	1503 49-1269 *	
	2102 49-1011 *	2-DOOR SEDAN 6-passenger, 5-window sedan with luggage compartment in rear.	1502 49-1211 *	
	2124 49-1027 *	SPORT COUPE 6-passenger, 2-door, 5-window coupe with luggage compartment in rear.	1524 49-1227 *	
		BUSINESS COUPE 5-passenger, 2-door 5-window coupe with luggage compartments behind seat and in rear.	1504 49-1227B *	
	2134 49-1067X *	CONVERTIBLE COUPE 5-passenger, 2-door, 5-window coupe with luggage compartment in rear and folding top.		
	2119 49-1062 *	STEEL STATION WAGON 8-passenger, 4-door, 7-window, all-steel body with drop and lift gates in rear.		
	2109 49-1061 *	WOOD STATION WAGON 8-passenger, 4-door, 7-window, wood body with drop and lift gates in rear.		
		SEDAN DELIVERY 2-passenger, 3-door, 3-window, panel delivery.	1508 49-1271 *	

\* - Flamer Body style number.

## 1949 DELUXE CHEVROLET DATA



MODEL	MODEL #	BODY/ STYLE #	PROD. FIGURES	BODY TYPE & SEATING	FACTORY PRICE	WEIGHT
Style Convertible	2134	1067x	32,392	2 dr/Conv/5P	1875	3375
4-dr. Style Sport Sedan	2103	1069	191,352	4 dr/6P	1539	3125
2-dr. Style Town Sedan	2102	1011	147,437	2 dr/6P	1492	3100
2-dr. Style Sport Coupe	2124	1027	78,785	2 dr/6P	1508	3065
4-dr. Wood bodied Wgn.	2109	1061	3,342	4 dr/8P	2267	3485
4-dr. Steel bodied Wgn.	2119	1062	2,664	4 dr/8P	2267	3465
Fleet 2-dr. Sedan	2152	1007	180,251	2 dr/6P	1492	3100
Fleet 4-dr. Sedan	2153	1008	130,323	4 dr/6P	1539	3135







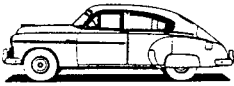
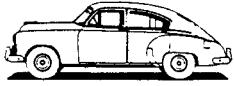

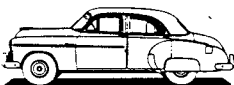

## 1949 SPECIAL CHEVROLET DATA

MODEL	MODEL #	BODY/ STYLE #	PROD. FIGURES	BODY TYPE & SEATING	FACTORY PRICE	WEIGHT
4-dr. Style Sport Sedan	1503	1209	46,334	4 dr/6P	1460	3090
2 dr. Style Town Sedan	1502	1211	69,398	2 dr/6P	1413	3070
2-dr. Style Sport Coupe	1524	1227	27,497	2 dr/6P	1418	3030
2-dr. Style Bus. Coupe	1504	1227B	20,337	2 dr/3P	1339	3105
4-dr. Fleet 4-dr. Sedan	1553	1208	36,317	4 dr/6P	1460	3095
2-dr. Fleet 2 dr. Sedan	1552	1207	58,514	2 dr/6P	1413	3060
Sedan Delivery	1508	1271	9,310	2 dr/2P	—	4100

# 1950 MODEL IDENTIFICATION

## 1949-50 Chevrolet

De Luxe - Series 2100		FLEETLINE		Special - Series 1500	
Vehicle Type	Model	Name and Description	Model	Vehicle Type	
	2153 50-1008 *	<u>4-DOOR SEDAN</u> 6-passenger, 5-window sedan with luggage compartment in rear	1553 50-1208 *		
	2152 50-1007 *	<u>2-DOOR SEDAN</u> 6-passenger, 5-window sedan with luggage compartment in rear	1552 50-1207 *		

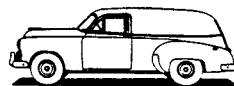
De Luxe - Series 2100		STYLELINE		Special - Series 1500	
Vehicle Type	Model	Name and Description	Model	Vehicle Type	
	2103 50-1069 *	<u>4-DOOR SEDAN</u> 6-passenger, 5-window sedan with luggage compartment in rear	1503 50-1269 *		
	2102 50-1011 *	<u>2-DOOR SEDAN</u> 6-passenger, 5-window sedan with luggage compartment in rear	1502 50-1211 *		
	2124 50-1027 *	<u>SPORT COUPE</u> 6-passenger, 2-door, 5-window coupe with luggage compartment in rear	1524 50-1227 *		
		<u>BUSINESS COUPE</u> 3-passenger, 2-door, 5-window coupe with luggage compartments behind seat and in rear	1504 50-1227B *		
	2134 50-1067X *	<u>CONVERTIBLE COUPE</u> 5-passenger, 2-door, 5-window coupe with folding top; luggage compartment in rear			
	2154 50-1037 *	<u>BEL AIR COUPE</u> 6-passenger, 2-door, 5-window coupe with hard top; luggage compartment in rear			
	2119 50-1062 *	<u>STATION WAGON</u> 8-passenger, 4-door, 7-window, all-steel body with drop and lift gates in rear			
		<u>SEDAN DELIVERY</u> 2-passenger, 3-door, 3-window, panel delivery	1508 50-1271 *		

\* - Fisher Body style number

### DID YOU KNOW? ...

- The wheelbase of the 1949 Chev was shortened 1" to 115" but looked longer than previous models.
- In 1949 Chevrolet had 2 Station Wagons - a conventional wooden bodied model and an all-steel version which looked almost identical from a short distance away.
- 1950 brought a real winner - Powerglide - the first automatic transmission to appear in the low price field.
- In 1950 the car length was increased to 197.5" but the wheelbase remained 115".

### 1950 DELUXE CHEVROLET DATA





MODEL	MODEL #	BODY/STYLE #	PROD. FIGURES	BODY TYPE & SEATING	FACTORY PRICE	WEIGHT
Styleline BelAir	2154	1037	76,662	2 dr/5P	1741	3225
Styleline Conv.	2134	1067x	32,810	2 dr/5P	1847	3380
4-dr. Styleline Sport Sedan	2103	1069	316,412	4 dr/6P	1529	3150
2-dr. Styleline Town Sedan	2102	1011	248,567	2 dr/6P	1482	3100
2-dr. Styleline Sport Coupe	2124	1027	81,536	2 dr/6P	1498	3090
4-dr. Styleline Station Wgn.	2119	1062	166,995	4 dr/8P	1994	3460
Fleetline 2-dr. Sedan	2152	1007	189,509	2 dr/6P	1482	3115
Fleetline 4-dr. Sedan	2153	1008	124,187	4 dr/6P	1529	3145









### 1950 SPECIAL CHEVROLET DATA

MODEL	MODEL #	BODY/STYLE #	PROD. FIGURES	BODY TYPE & SEATING	FACTORY PRICE	WEIGHT
4-dr. Styleline Sport Sedan	1503	1269	55,644	4 dr/6P	1450	3120
2-dr. Styleline Town Sedan	1502	1211	89,897	2 dr/6P	1403	3085
2 dr. Styleline Sport Coupe	1524	1227	28,328	2 dr/6P	1408	3050
2 dr. Styleline Bus. Coupe	1504	1227B	20,984	2 dr/3P	1329	3025
4-dr. Fleetline Sedan	1553	1208	23,277	4 dr/6P	1450	3115
2-dr. Fleetline Sedan	1552	1207	43,682	2 dr/6P	1403	3080
Sedan Delivery	1508	1271	23,045	3 dr/2P	—	3100

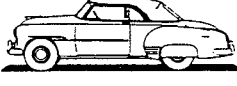

# 1951 MODEL IDENTIFICATION

De Luxe - Series 2100		FLEETLINE		
Vehicle Type	Model	Name and Description	Model	Special - Series 1500 Vehicle Type
	2153 51-1008 *	<u>4-DOOR SEDAN</u> 6-passenger, 5-window sedan with luggage compartment in rear	1553 51-1208 *	
	2152 51-1007 *	<u>2-DOOR SEDAN</u> 6-passenger, 5-window sedan with luggage compartment in rear	1552 51-1207 *	

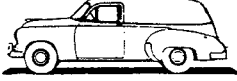
De Luxe - Series 2100		STYLELINE		
Vehicle Type	Model	Name and Description	Model	Special - Series 1500 Vehicle Type
	2103 51-1069 *	<u>4-DOOR SEDAN</u> 6-passenger, 5-window sedan with luggage compartment in rear	1503 51-1269 *	
	2102 51-1011 *	<u>2-DOOR SEDAN</u> 6-passenger, 5-window sedan with luggage compartment in rear	1502 51-1211 *	
	2124 51-1027 *	<u>SPORT COUPE</u> 6-passenger, 2-door, 5-window coupe with luggage compartment in rear	1524 51-1227 *	
		<u>BUSINESS COUPE</u> 3-passenger, 2-door, 5-window coupe with luggage compartments behind seat and in rear	1524 51-1227B *	
	2134 51-1067TX *	<u>CONVERTIBLE COUPE</u> 5-passenger, 2-door, 5-window coupe with folding top; luggage compartment in rear		
	2154 51-1037 *	<u>BEL AIR COUPE</u> 6-passenger, 2-door, 5-window coupe with hard top; luggage compartment in rear		
	2119 51-1062 *	<u>STATION WAGON</u> 8-passenger, 4-door, 7-window, all-steel body with drop and lift gates in rear		
		<u>SEDAN DELIVERY</u> 2-passenger, 3-door 3-window, panel delivery	1508 51-1271 *	

\* - Fisher Body style number.

## 1951 DELUXE CHEVROLET DATA

MODEL	MODEL #	BODY/ STYLE #	PROD. FIGURES	BODY TYPE & SEATING	FACTORY PRICE	WEIGHT
BelAir Hardtop Coupe	2154	1037	103,356	2 dr/6P	1914	3225
Convertible	2134	1067TX	20,172	2 dr/5P	2030	3380
4-dr. Styleline Sedan	2103	1069	380,270	4 dr/6P	1680	3150
2-dr. Styleline Sedan	2102	1011	262,933	2 dr/6P	1629	3110
Styleline Sport Coupe	2124	1027	64,976	2 dr/6P	1647	3115
Styleline Station Wagon	2119	1062	23,586	4 dr/8P	2191	3470
2-dr. Fleetline Sedan	2152	1007	131,910	2 dr/6P	1629	3125
4-dr. Fleetline Sedan	2153	1008	57,693	4 dr/6P	1680	3155

## 1951 SPECIAL CHEVROLET DATA



MODEL	MODEL #	BODY/ STYLE #	PROD. FIGURES	BODY TYPE & SEATING	FACTORY PRICE	WEIGHT
4-dr. Styleline Sedan	1503	1269	63,718	4 dr/6P	1594	3130
2-dr. Styleline Sedan	1502	1211	75,566	2 dr/6P	1540	3095
Styleline Sport Coupe	1524	1227	18,981	2 dr/6P	1545	3060
Styleline Bus. Coupe	1504	1227B	17,020	2 dr/3P	1460	3040
4-dr. Fleetline Sedan	1553	1208	3,364	4 dr/6P	1594	3130
2 dr. Fleetline Sedan	1552	1207	6,441	2 dr/6P	1540	3090
Sedan Delivery	1508	1271	20,817	3 dr/2P	1648	3100







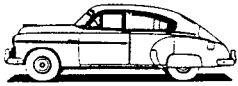
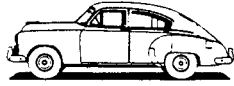

# 1952 MODEL IDENTIFICATION

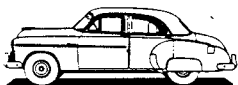
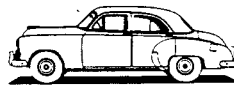
## 1951-52 Chevrolet

### DID YOU KNOW? ...

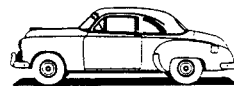
- 1951 brought few changes to Chevrolet - it grew again to 197.8" but the wheelbase remained 115".
- Bendix brakes replaced Huck brakes and after an absence of 1 year Carter Carbs were used along with Stromberg and Rochester's.
- 1952 changes were primarily the new but similar horizontal grill with five perssed "teeth" in the central bar.
- Adding to the cosmetic appeal of the new grill this year's Chevrolet had the largest selection of body colors and two-tone combinations ever in a low price line of car with a choice of 129 colors and two-tone exterior and interior variations.

De Luxe - Series 2100		FLEETLINE		Special - Series 1500	
Vehicle Type	Model	Name and Description	Model	Vehicle Type	
	2153 50-1008 *	4-DOOR SEDAN 6-passenger, 5-window sedan with luggage compartment in rear	1553 50-1208 *		
	2152 50-1007 *	2-DOOR SEDAN 6-passenger, 5-window sedan with luggage compartment in rear	1552 50-1207 *		

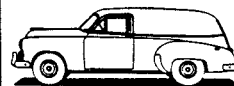
De Luxe - Series 2100		STYLELINE		Special - Series 1500	
Vehicle Type	Model	Name and Description	Model	Vehicle Type	
	2103 50-1069 *	4-DOOR SEDAN 6-passenger, 5-window sedan with luggage compartment in rear	1503 50-1269 *		
	2102 50-1011 *	2-DOOR SEDAN 6-passenger, 5-window sedan with luggage compartment in rear	1502 50-1211 *		
	2124 50-1027 *	SPORT COUPE 6-passenger, 2-door, 5-window coupe with luggage compartment in rear	1524 50-1227 *		
		BUSINESS COUPE 3-passenger, 2-door, 5-window coupe with luggage compartments behind seat and in rear	1504 50-1227B *		
	2134 50-1067X *	CONVERTIBLE COUPE 5-passenger, 2-door, 5-window coupe with folding top; luggage compartment in rear			
	2154 50-1037 *	BEL AIR COUPE 6-passenger, 2-door, 5-window coupe with hard top; luggage compartment in rear			
	2119 50-1062 *	STATION WAGON 8-passenger, 4-door, 7-window, all-steel body with drop and lift gates in rear			
		SEDAN DELIVERY 2-passenger, 3-door, 3-window, panel delivery	1508 50-1271 *		

\* - Fisher Body style number

### 1952 DELUXE CHEVROLET DATA

MODEL	MODEL #	BODY/ STYLE #	PROD. FIGURES	BODY TYPE & SEATING	FACTORY PRICE	WEIGHT
BelAir Hardtop Coupe	2154	1037	74,634	2 dr/6P	2006	3215
Convertible	2134	1067TX	11,975	2 dr/5P	2128	3380
4-dr. Styleline Sedan	2103	1069	319,736	4 dr/6P	1761	3145
2 dr. Styleline Sedan	2102	1011	215,417	2 dr/6P	1707	3110
Styleline Sport Coupe	2124	1027	36,954	2 dr/6P	1726	3100
Styleline Station Wagon	2119	1062	12,756	4 dr/8P	2297	3475
2-dr. Fleetline Sedan	2152	1007	37,164	2 dr/6P	1707	3110

### 1952 SPECIAL CHEVROLET DATA

MODEL	MODEL #	BODY/ STYLE #	PROD. FIGURES	BODY TYPE & SEATING	FACTORY PRICE	WEIGHT
4-dr. Styleline Sedan	1503	1269	35,460	4 dr/6P	1670	3115
2-dr. Styleline Sedan	1502	1211	54,781	2 dr/6P	1614	3085
2 dr. Styleline Sport Coupe	1524	1227	8,906	2 dr/6P	1620	3050
2 dr. Styleline Bus. Coupe	1504	1227B	10,359	2 dr/3P	1530	3045
Sedan Delivery	1508	1271	9,175	3 dr/2P	1648	3100



















# 1953 MODEL IDENTIFICATION

## 1953 Chevrolet

### DID YOU KNOW? ...

- '53 was the first year for a one-piece wrap-around windshield and all models except the 150 Series had a wrap-around rear window as well.
- In 1953 seventeen models were available — the most ever offered by Chevrolet.
- '53 was the first year for Chevrolet power steering.
- '53 was the first year the BelAir Model was available in Sedans. The BelAir Hardtop became known as the Sport Coupe in 1953.
- In 1953, Chevrolet's theme in their advertising campaign was "Mister Chevrolet," a top hatted tuxedoed image of a well-to-do man-about-town whose good taste brought him to Chevrolet to buy a new car.
- More than 1,300,000 1953 Chevrolets were produced and over 400,000 were equipped with a powerglide transmission.

Name and Description	One-Fifty - Series 1500	Two-Ten - Series 2100	Bel Air - Series 2400
4-DOOR SEDAN 6-passenger, 5-window sedan with luggage compartment in rear			
MODEL	1503; 53-1269 *	2103; 53-1069W *	2403; 53-1069WD *
2-DOOR SEDAN 6-passenger, 5-window sedan with luggage compartment in rear			
MODEL	1502; 53-1211 *	2102; 53-1011W *	2402; 53-1011WD *
CLUB COUPE 6-passenger, 2-door, 5-window coupe with luggage compartment in rear			
MODEL	1524; 53-1227 *	2124; 53-1027 *	
BUSINESS COUPE 3-passenger, 2-door, 5-window coupe with luggage compartments behind seat and in rear			
MODEL	1504; 53-1227B *		
SPORT COUPE 6-passenger, 2-door, 5-window coupe with hardtop; luggage compartment in rear			
MODEL		2154; 53-1037 *	2454; 53-1037D *
CONVERTIBLE 5-passenger, 2-door, 5-window coupe with folding top; luggage compartment in rear			
MODEL		2134; 53-1067TX *	2434; 53-1067DTX *
STATION WAGON (HANDYMAN) 6-passenger, 4-door, 7-window, all-steel body with drop and lift gates in rear			
MODEL	1509; 53-1262F *	2109; 53-1062F *	
STATION WAGON (TOWNSMAN) 8-passenger, 4-door, 7-window, all-steel body with drop and lift gates in rear			
MODEL		2119; 53-1062 *	
SEDAN DELIVERY 2-passenger, 3-door, 3-window panel delivery			
MODEL	1508; 53-1271 *		















\* - Fisher Body style number  
3-16-53

#### 8 - MODEL IDENTIFICATION

#### CHEVROLET 1953 SPECIFICATIONS—PASSENGER

1953 MODEL	MODEL #	BODY/STYLE #	PRODUCTION FIGURES	BODY TYPE & SEATING	FACTORY PRICE	WEIGHT
<b>BEL AIR SERIES</b>						
Convertible	2434	1067D	24,047	2-dr. Conv./5P	\$2175	3470
2-Door Hardtop	2454	1037D	99,028	2-dr. Sp. Cpe./6P	\$2051	3310
2-Door Sedan	2402	1011WD	144,401	2-dr. Sedan/6P	\$1820	3230
4-Door Sedan	2403	1069WD	247,284	4-dr. Sedan/6P	\$1874	3275
<b>DELUXE 210 SERIES</b>						
Convertible	2134	1067	5,167	2-dr. Conv./5P	\$2093	3470
2-Door Hardtop	2154	1037	14,045	2-dr. Sp. Cpe./6P	\$1967	3275
2-Door Sedan	2102	1011W	247,455	2-dr. Sedan/6P	\$1707	3215
4-Door Sedan	2103	1069W	332,497	4-dr. Sedan/6P	\$1761	3250
Club Coupe	2124	1027	23,961	2-dr. Clb. Cpe./6P	\$1726	3190
210 Station Wagon	2109	1062F	18,258	4-dr. Wagon/6P	\$2123	3450
210 Townsman Wagon	2119	1062	7,988	4-dr. Wagon/8P	\$2273	3495
<b>SPECIAL 150 SERIES</b>						
2-Door Sedan	1502	1211	79,416	2-dr. Sedan/6P	\$1613	3180
4-Door Sedan	1503	1269	54,207	4-dr. Sedan/6P	\$1670	3215
Business Coupe	1504	1227B	13,555	2-dr. Bus. Cpe./6P	\$1524	3140
Club Coupe	1524	1227	6,993	2-dr. Clb. Cpe./6P	\$1620	3140
Station Wagon	1509	1262F	22,408	4-dr. Wagon/6P	\$2010	3420
Sedan Delivery	1508		15,523	1 or 2 P	\$1648	3160

# 1954 MODEL IDENTIFICATION

Name and Description	One-Fifty-Series 1500	Two-Ten-Series 2100	Bel Air-Series 2400
<b>4-DOOR SEDAN</b> 6-passenger, 5-window sedan with luggage compartment in rear			
MODEL	1503; 54-1269W*	2103; 54-1069W*	2403; 54-1069WD*
<b>2-DOOR SEDAN</b> 6-passenger, 5-window sedan with luggage compartment in rear			
MODEL	1502; 54-1211W*	2102; 54-1011W*	2402; 54-1011WD*
<b>CLUB COUPE</b> 6-passenger, 2-door, 5-window coupe with luggage compartment in rear			
MODEL		2124; 54-1011WA*	
<b>UTILITY SEDAN</b> 3-passenger, 5-window sedan with luggage compartment in rear			
MODEL	1512; 54-1211WB*		
<b>SPORT COUPE</b> 6-passenger, 2-door 5-window coupe with hard top; luggage compartment in rear			
MODEL			2454; 54-1037D*
<b>CONVERTIBLE</b> 5-passenger, 2-door, 5-window coupe with folding top; luggage compartment in rear			
MODEL			2434; 54-1067DTX*
<b>STATION WAGON (HANDYMAN)</b> 6-passenger, 4-door, 7-window, all-steel body with drop and lift gates in rear			
MODEL	1509; 54-1262F*	2109; 54-1062F*	
<b>STATION WAGON (TOWNSMAN)</b> 8-passenger, 4-door, 7-window, all-steel body with drop and lift gates in rear			
MODEL			2419; 54-1062D*
<b>SEDAN DELIVERY</b> 2-passenger, 3-door, 3-window panel delivery			
MODEL	1508; 54-1271*		

\*-Fisher body style number  
12-18-53

## 8 - MODEL IDENTIFICATION

## CHEVROLET 1954 SPECIFICATIONS—PASSENGER

# 1954 Chevrolet

## DID YOU KNOW? ...

- 1954 was the first year the automatic transmission was available in all Chevrolet models.
- 1954 was the last year for the exclusive use of the 6 cylinder engine, and the last year for 6 volt electrical systems in Chevrolets.
- The 1954 grill teeth are the number one choice of street rodders to customize their grill. '54 Chev grill teeth are found in a lot of customized ... Mercurys!
- 1954 was the first year for power brakes, power seats and power windows.
- 1954 was the first year that a coupe body style was not available. Business Coupes were a 2 door Sedan without a back seat.
- The 1954 Townsman Wagon was the last Chevrolet Station Wagon to use the imitation wood decor until the 1966 Caprice came along.
- Calendar year sales for the 1954 Chevrolet totaled 1,414,352.

1954 MODEL	MODEL #	BODY/STYLE #	PRODUCTION FIGURES	BODY TYPE & SEATING	FACTORY PRICE	WEIGHT
<b>BEL AIR SERIES</b>						
Convertible	2434	1067D	19,383	2-dr. Conv./5P	\$2185	3445
2-Door Hardtop	2454	1037D	66,378	2-dr. Sp. Cpe./6P	\$2061	3300
2-Door Sedan	2402	1011WD	143,573	2-dr. Sedan/6P	\$1830	3220
4-Door Sedan	2403	1069WD	248,750	4-dr. Sedan/6P	\$1884	3255
Station Wagon	2419	1062D	8,156	4-dr. Wagon/8P	\$2283	3540
<b>DELUXE 210 SERIES</b>						
2-Door Sedan	2102	1011W	194,498	2-dr. Sedan/6P	\$1717	3185
4-Door Sedan	2103	1069W	235,146	4-dr. Sedan/6P	\$1771	3230
2-Door Delray	2124	1011WA	66,403	2-dr. Delray/6P	\$1782	3185
Station Wagon	2109	1062F	27,175	4-dr. Wagon/6P	\$2133	3470
<b>SPECIAL 150 SERIES</b>						
2-Door Sedan	1502	1211W	64,855	2-dr. Sedan/6P	\$1623	3165
4-Door Sedan	1503	1269W	32,430	4-dr. Sedan/6P	\$1680	3210
Utility Sedan (Business Coupe)	1512	1211WB	10,770	2-dr. Sedan/3P	\$1539	3145
Station Wagon	1509	1262F	21,404	4-dr. Wagon/6P	\$2020	3455
Sedan Delivery	1508		8,255	1 or 2 P	\$1632	3195



# 1949-50 CHEV CONTINENTAL KIT



National Chevy's Basic Continental Kit is an affordable way to "customize" your 1949 to 1950 Chevy, but don't let the low price fool you. It is a complete quality kit **proudly made in the USA!** Any backyard mechanic can install it over a weekend. Paint to match your car. The tire ring is heavy gauge polished stainless steel and the face plate is solid plastic. **All hardware and instructions included.** A great kit at a great price!

ORDER #CK-9

**\$ 1 195<sup>00</sup>**

# 1951-52 CHEV CONTINENTAL KIT



National Chevy's Basic Continental Kit is an affordable way to "customize" your 1951 to 1952 Chevy, but don't let the low price fool you. It is a complete quality kit **proudly made in the USA!** Any backyard mechanic can install it over a weekend. Paint to match your car. The tire ring is heavy gauge polished stainless steel and the face plate is solid plastic. **All hardware and instructions included.** A great kit at a great price!

ORDER #CK-10

**\$ 1 195<sup>00</sup>**

# 1953-54 CHEV CONTINENTAL KIT



National Chevy's Basic Continental Kit is an affordable way to "customize" your 1953 or 1954 Chevy, but don't let the low price fool you. It is a complete quality kit proudly made in the USA! Any backyard mechanic can install it over a weekend. Paint to match your car. The tire ring is heavy gauge polished stainless and the face plate is solid plastic. All hardware and instructions included. A great kit at a great price!

ORDER #CK-1

**\$1 195<sup>00</sup>**

## CONTINENTAL KIT OPTIONS



Upgrade your Kit!  
Display your hubcap with this open  
fiberglass face plate.

ORDER #CK-3  
**\$99<sup>00</sup>**



Stainless steel tire ring.

ORDER #2147SS  
**\$195<sup>00</sup>**



*Flat Faceplate available separately – Call for price*



# the ADVENTURES of **Barnie**

YOU EVER FIND IT MUCH OF A PROBLEM TO PARK THIS RIG?

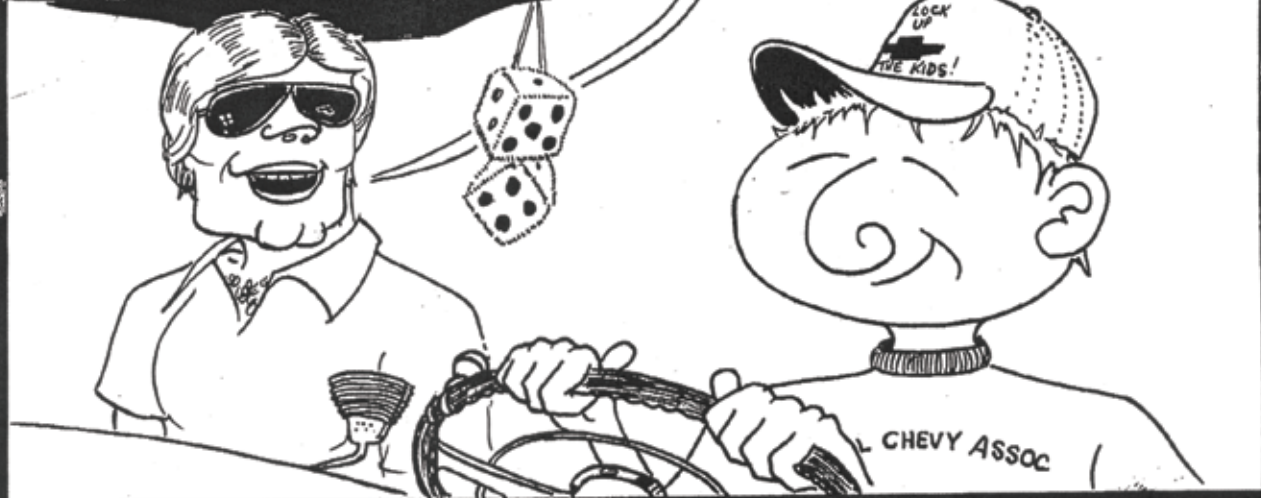

NAH.... NOT REALLY.

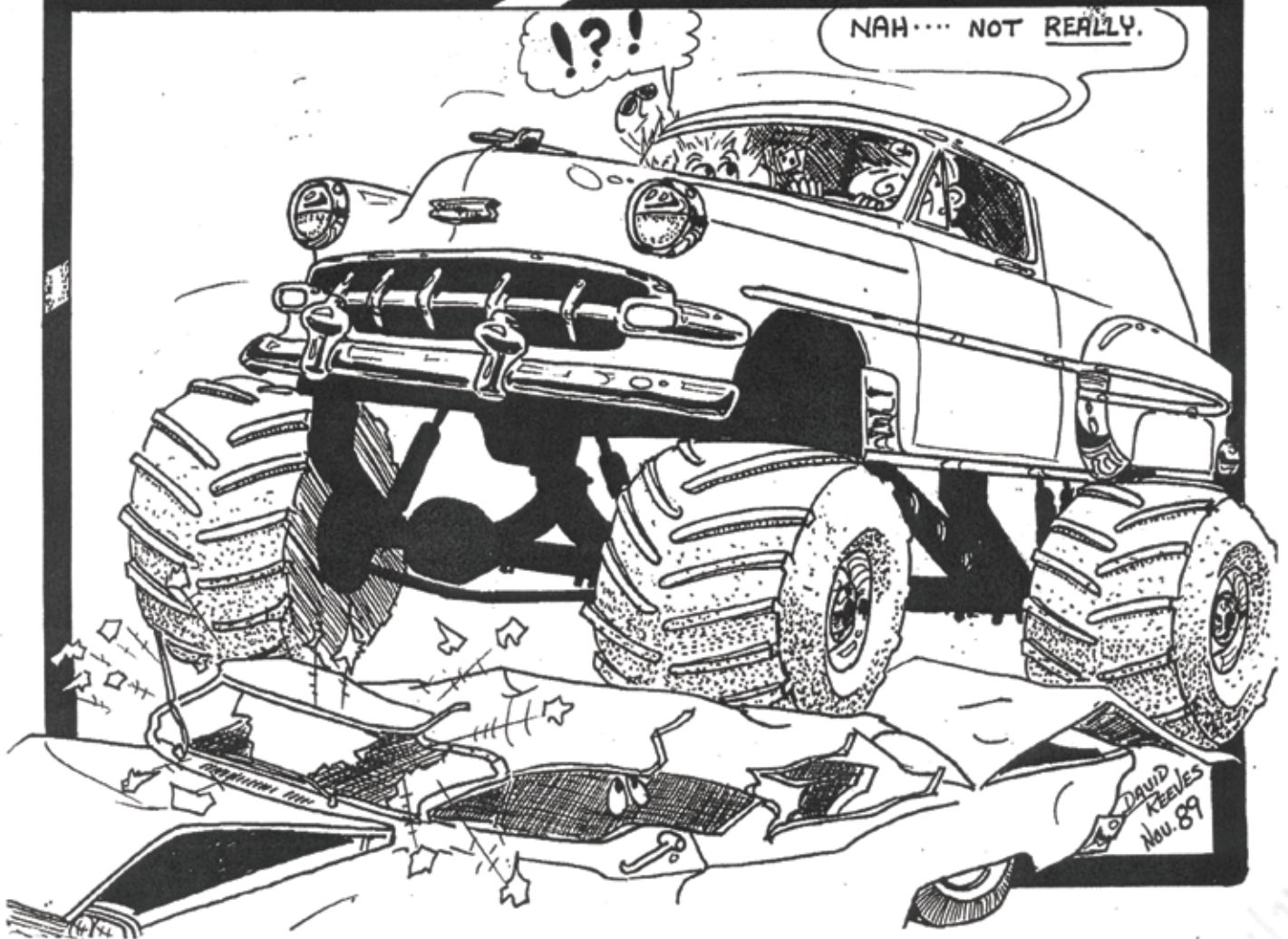

# CUSTOM HUBCAPS/HEADLIGHT ACCESSORIES

## "BULLET" HEADLIGHT COVERS

Make your point, or points!  
Nicknamed the "Madonna" headlight covers  
(for obvious reasons.)

ORDER #2127 **\$27<sup>00</sup>**



## HALF MOON HEADLIGHT COVERS

Excellent chrome

ORDER #2103

**\$17<sup>00</sup>** pr.



## BLUE DOT HEADLIGHT COVERS

Chrome plated headlight covers with blue dot  
installed in center. Very custom!

ORDER #2128 **\$19<sup>00</sup>** pr.



## BASEBALL CAP HEADLIGHT VISOR

Excellent chrome.  
Mounts under  
headlight rim.

ORDER #2112

**\$21<sup>00</sup>** pr.



## "CAT EYE" HEADLIGHT COVERS

Great chrome

ORDER #2102

**\$16<sup>00</sup>** pr.



## 3 BAR SPINNER HUBCAP

Styled after some of the  
50's hubcaps.  
These are a  
nice chrome with  
white in squares.

ORDER #2136

**\$135<sup>00</sup>** set of 4



## 4 BAR SPINNER HUBCAP

Another nice custom  
50's style hubcap.  
Chrome with white in squares.

ORDER #2137

**\$260<sup>00</sup>** set of 4



Shown at right is  
1954 Chev with Blue Dot  
Covers (#2128)







## CAR CARE ACCESSORIES

### BATTERY TENDER

Lightweight and compact. Keeps batteries constantly ready to go. Great for stored vehicles.



6V  
ORDER #2161  
**\$55<sup>00</sup>**

12V  
ORDER #2162  
**\$55<sup>00</sup>**



### CALIFORNIA WATER BLADE

Whether you wash it or want to remove rain, these work great!



ORDER #2160  
**\$29<sup>00</sup>**

### CALIFORNIA CAR DUSTER

Everyone needs a duster! Keeps dust off your car. Works great!



ORDER #2158  
**\$33<sup>00</sup>**

# 1953-54 "BELAIR BLOOMERS"

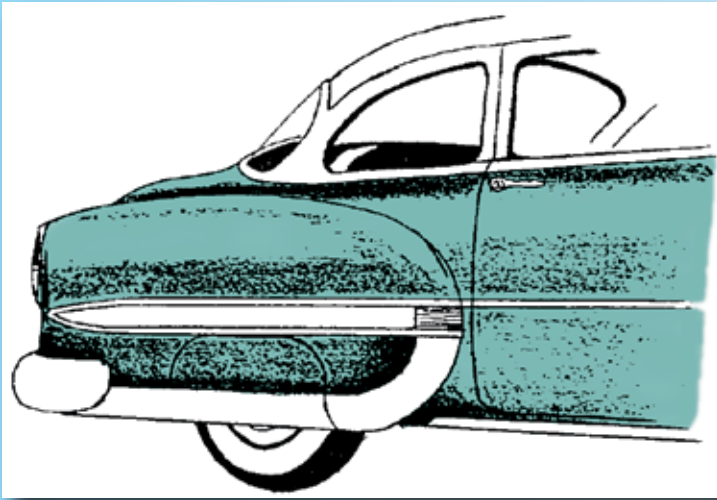

*Only*  
**\$169<sup>00</sup>** pr.  
 ORDER #557

*Beautiful stainless reproductions of the original BelAir Bloomers.*

*These fit on the bottom of the fender skirt and complete the lower body line.*

- LONGER:** Lengthens appearance of car.
- LOWER:** Car looks low and sleek
- STYLE:** Completes natural style of body.

## FITS ALL MODELS WITH FENDERSKIRTS! 2 OR 4 DOORS

Includes hardware and installation instructions.

*ALTHOUGH ORIGINALLY CALLED THE BELAIR BLOOMERS, THESE BLOOMERS LOOK FANTASTIC ON YOUR 210 MODEL. ADDS A LOT OF "SPARKLE" TO THE SIDE OF YOUR 210 AT AN AFFORDABLE PRICE.*



### BULL NOSE HOOD STRIP

For that "smooth hood" custom look. Remove old hood molding and emblems and install new strip.

**Easy as 1, 2, 3.**

Includes instructions and hardware. Looks good!

1949-52 ORDER #2114-1

1953-54 ORDER #2114

**\$79<sup>95</sup>**



### CAL CUSTOM "DUMMY" SPOTLIGHTS

**For decoration use only,** these really are just "dummies." Nice chrome finish adds a nice touch to your mild or wild custom.

ORDER #2125

**\$135<sup>00</sup>** pr.





# 1949-50 LITERATURE



*A must have*

## SHOP MANUAL

ORDER #104 **\$25<sup>00</sup>**

The shop manual is the best investment you can make if you own a collectible car. Fully explained is operation, overhaul, removal, electrical, glass installation, etc., in easy-to-understand language.

Covers 1949-1954 Chevs.



## 1949 OWNERS MANUAL

ORDER #4105  
**\$14<sup>00</sup>**

Explains operation of car, tire pressure, maintenance and more.



## 1949 CHEV OWNERS MANUAL SET

Includes owners manual, envelope and accessory list.

ORDER #4166  
**\$25<sup>00</sup>**

## 1949 CHEV SALES BROCHURE

Excellent quality color brochure. Approximately 15x21

ORDER #4113  
**\$12<sup>00</sup>**



## 1950 CHEV OWNERS MANUAL



Explains car operation, tire pressure, and more.

ORDER #4106  
**\$14<sup>00</sup>**

## 1950 CHEV OWNERS MANUAL SET



Includes owners manual, envelope, accessory price list.

ORDER #4167  
**\$26<sup>00</sup>**

## 1950 CHEV SALES BROCHURE



ORDER #4114  
**\$12<sup>00</sup>**

# 1951-52 LITERATURE

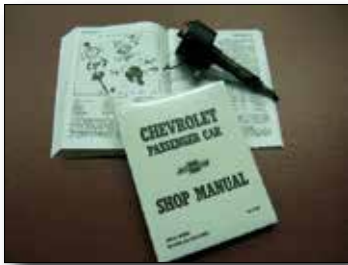

## SHOP MANUAL

The shop manual is the best investment you can make if you own a collectible car. Manual explains operation, overhaul, removal, electrical, glass installation, headliner installation and much more in easy-to-understand language. **Covers 1949-54 Chevs.**

ORDER #104

**\$25<sup>00</sup>**

## 1952 OWNERS MANUAL



Explains operation of the car, tire pressure, proper maintenance & more.

ORDER #4108

**\$14<sup>00</sup>**



## 1951 CHEV OWNERS MANUAL

ORDER #4107

**\$14<sup>00</sup>**

Explains operation of the car and much more.

## 1952 CHEV OWNERS MANUAL SET

Includes owners manual, envelope and accessory price list.

ORDER #4169

**\$22<sup>00</sup>**

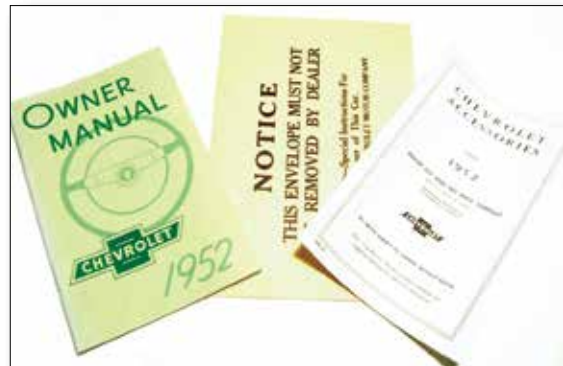

## 1951 CHEV OWNERS MANUAL SET



Includes owners manual, envelope and accessory price list.

ORDER #4168

**\$26<sup>00</sup>**

## 1951 SALES BROCHURE

Color brochure. Approximately 15x21

ORDER #4115

**\$12<sup>00</sup>**



## 1952 SALES BROCHURE

Color brochure approximately 15x21.

ORDER #4116

**\$12<sup>00</sup>**





# 1949-52 LITERATURE

## BOOKLETS

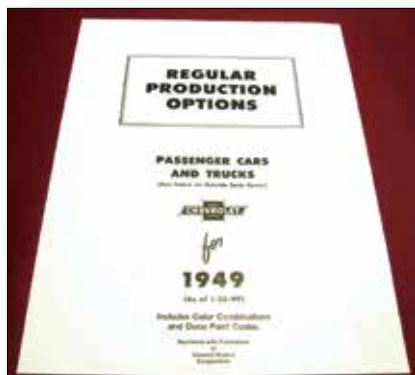

### 1949 CHEV REGULAR PRODUCTION OPTIONS

ORDER #4131  
**\$9<sup>00</sup>**



### CONVERTIBLE FOLDING TOP OPERATION MANUAL

ORDER #4132 **\$8<sup>00</sup>**

## SERVICE BULLETINS

Sent monthly by Chevrolet to update dealers on maintenance and changes. Sold by the calendar year, 12 issues per set.



**1949 CHEV** ORDER #4162  
**1950 CHEV** ORDER #4163  
**1951 CHEV** ORDER #4164  
**1952 CHEV** ORDER #4165

*Only* **\$20<sup>00</sup>** set

## VISOR SLEEVE

One side explains operation of powerglide transmission, opposite side has maintenance guides.



ORDER #4161 **\$8<sup>00</sup>**



# 1949-52 LITERATURE



**1949 CHEV**  
ORDER #4118



**1950 CHEV**  
ORDER #4119



**1951 CHEV**  
ORDER #4120



**1952 CHEV**  
ORDER #4121

## ACCESSORY INSTALLATION MANUALS

This manual explains how to install Chevrolet accessories such as radio, antenna, rear seat speaker, etc.

Only **\$24** ea.

## 1949 SERVICE AND CONSTRUCTION MANUAL

All we can find is '49 but may be helpful for other years.

ORDER #4117  
**\$14.00**



## 1950 CHEV RADIO INSTALLATION AND OPERATION MANUAL (PUSH BUTTON)

ORDER #4112  
**\$7.00**



# FACTORY INFORMATION TAGS



**BATTERY WARRANTY CERTIFICATE**  
ORDER #216  
**\$6.00**



**COMPASS INSTRUCTION DECAL**  
ORDER #219  
**\$6.00**



**CASCO LIGHTER TAG**  
ORDER #221  
**\$6.00**



**CHEVROLET FACTORY QUALITY CONTROL CHECK CARD**  
ORDER #224  
**\$7.00**



**CHEVROLET OWNER SERVICE POLICY**  
ORDER #223  
**\$7.00**



**1949/50 HEATER CONTROL TAG**  
ORDER #4237  
**\$7.00**



**SERVICE POLICY**  
ORDER #4235  
**\$7.00**



**FACTORY BUILD SHEET**  
ORDER #4239  
**\$7.00**



**1951/52 HEATER CONTROL TAG**  
ORDER #4240  
**\$6.00**



**HEATER BLOWER TUBE DECAL**  
ORDER #4241  
**\$7.00**



**DEFROSTER DECAL**  
ORDER #4242  
**\$6.00**



**HARRISON HEATER DECAL**  
ORDER #4243  
**\$6.00**



# 1949-52 DECALS



**AIR CLEANER OIL BATH DECAL**

ORDER #201 **\$6<sup>00</sup>**



**TRICO WASHER DECAL**

ORDER #4236 **\$6<sup>00</sup>**



**ELEMENT TYPE AIR CLEANER DECAL**

ORDER #205 **\$6<sup>00</sup>**



**RADIATOR OVERFLOW**

ORDER #231 **\$8<sup>00</sup>**



**BLUE FLAME**

ORDER #4238 **\$8<sup>00</sup>**

*Prices in catalog are subject to change without notice.*

*Prices at [www.nationalchevyassoc.com](http://www.nationalchevyassoc.com) are always current.*



# 1953 LITERATURE



*A must  
have*

## SHOP MANUAL

ORDER #104

**\$25<sup>00</sup>**

The shop manual is the best investment you can make if you own a collectible car. Fully explained is operation, overhaul, removal, electrical, glass installation, etc., in easy-to-understand language.  
Covers 1953 and contains 1954 supplement.

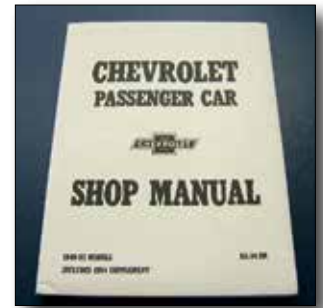

## 1953 OWNERS MANUAL

ORDER #101 **\$12**

This exact reproduction explains operation, maintenance, controls, weights, tire pressure, etc. Every car had one of these in the glove box when new. High quality, display with your car.

## 1953 OWNERS MANUAL SET



This set includes owners manual, accessory list-price sheet and printed envelope.

ORDER #139  
**\$18<sup>00</sup>**

## 1953 SALES BROCHURE

Color brochure features all models available in 1953. Foldout is 15" x 21"

ORDER #102  
**\$12<sup>00</sup>**



## 1953 ACCESSORY INSTALLATION MANUAL



Detail illustration of all accessories with part numbers and how they are installed. Great for installing accessories from other cars.

ORDER #129  
**\$20<sup>00</sup>**

## 1953 SERVICE BULLETINS



Sent monthly by Chevrolet to update dealers on maintenance and changes. Sold by calendar year. 12 issues per set

ORDER #120 **\$23<sup>00</sup>**



# 1954 LITERATURE



## SHOP MANUAL

The shop manual is the best investment you can make if you own a collectible car. Fully explained is operation, overhaul, removal, electrical, glass installation, etc., in easy-to-understand language.

Covers 1953 and contains 1954 supplement.

ORDER #104

**\$25<sup>00</sup>**



## 1954 OWNERS MANUAL

ORDER #105

**\$12<sup>00</sup>**

This booklet explains operation, maintenance, controls, tire pressure, etc. Designed to acquaint you with your new car. Every car had a manual in the glove box when new.

## 1954 OWNERS MANUAL SET



This set includes owners manual, accessory list and printed envelope. Store it in your glove box.

ORDER #140

**\$18<sup>00</sup>**

## SALES BROCHURE

Color brochure features all models available in 1954. 15" x 21" in size. Excellent quality.

ORDER #106

**\$12<sup>00</sup>**



## 1954 ACCESSORY INSTALLATION MANUAL

Detailed instructions for installing accessories such as outside sunvisor, radio, autronic eye, vent shades, back-up lamps, windshield washer. Good investment

ORDER #107



**\$22**

## 1954 SERVICE BULLETINS

Sent monthly by Chevrolet to update dealers on maintenance and changes.

Sold by calendar year. 12 issues per set.

ORDER #121

**\$18<sup>00</sup>**



## 1954 TOP OPERATION MANUAL

Reproduction booklet for 1954 convertible that contains information on top operation care, and maintenance of your car's top. A quality reproduction.

ORDER #135

**\$9<sup>00</sup>**



# 1954 LITERATURE

## 1954 REGULAR PRODUCTION OPTION BOOKLET



Covers options on 150, 210, BelAir Series such as color options, trim options and some misc. information such as cost of some options.

ORDER #159  
**\$9<sup>00</sup>**

## CHROME CARE BOOKLET

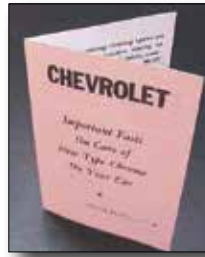

Chevrolet provided this handy booklet explaining how to maintain that "Showroom Shine"

ORDER #166  
**\$6<sup>00</sup>**

## "BODY BY FISHER" SERVICE NEWS FOR CONVERTIBLE TOP



Reprint that covers operation and care of top.

A must have for convertible owners.

ORDER #165  
**\$8<sup>00</sup>**

## TAGS



### ENGINE BREAK-IN CARD

ORDER #220  
**\$6<sup>00</sup>**

### CASCO LIGHTER TAG

ORDER #221  
**\$5<sup>00</sup>**



### BATTERY WARRANTY CERTIFICATE

ORDER #216  
**\$5<sup>00</sup>**

### AUTRONIC EYE INSTRUCTION

ORDER #222  
**\$7<sup>00</sup>**



### CHEVROLET OWNER SERVICE POLICY

ORDER #223  
**\$7<sup>00</sup>**

### HEATER INSTRUCTION

ORDER #226  
**\$6<sup>00</sup>**

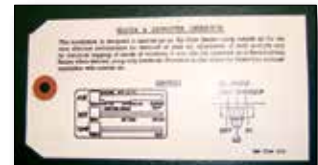

### CHEVROLET FACTORY QUALITY CONTROL CHECK CARD

ORDER #224  
**\$7<sup>00</sup>**

### 1954 CHEV WARRANTY CARD

ORDER #218  
**\$6<sup>00</sup>**



### KEY SLUG DECAL

ORDER #209  
**\$5<sup>00</sup>**



### 1954 ROCHESTER LIGHTER TAG

ORDER #217  
**\$5<sup>00</sup>**

### COMPASS INSTRUCTION DECAL

ORDER #219  
**\$5<sup>00</sup>**



### LACQUER PAINT INSTRUCTION CARD

ORDER #215  
**\$6<sup>00</sup>**





# 1949-54 LITERATURE

## USEFUL ACCESSORIES FOR 1953

Full color 1953 accessory brochure.



ORDER  
#127

**\$13**

## THE SPARKLING NEW LINE OF GENUINE CHEVROLET ACCESSORIES FOR '51

Booklet showing accessories for 1951 Chev. In Color

*New*

ORDER  
#4171

**\$14<sup>00</sup>**



## THE BEAUTIFUL BEL AIR

Full color brochure showing interior & exterior of 1950 hardtop.



ORDER  
#4170

**\$13<sup>00</sup>**

## USEFUL ACCESSORIES FOR 1954

Booklet shows pictures of accessories available in 1954 such as vanity mirror, floor mats, grill guards, shaver, tissue dispenser and more.

Very useful! Full color.



ORDER #111

**\$13<sup>00</sup>**

## USEFUL PASSENGER CAR ACCESSORIES FOR 1953

Reproduction full color booklet features accessories available for your 1953 Chev such as seat covers, deluxe hood bird, hubcaps, etc. Useful at swap meets for identifying correct accessory items.



ORDER  
#110

**\$14<sup>00</sup>**

## CHEVROLET ACCESSORIES

Printed like original in blue & white. Shows accessories available for 1950 Chev.



ORDER #4172

**\$14<sup>00</sup>**

## GENUINE CHEVROLET ACCESSORIES FOR 1952

Full color booklet showing accessories for 1952 Chev. Excellent reproduction.

ORDER #4173 **\$14<sup>00</sup>**



# 1953-54 FACTORY DECALS



**ELEMENT TYPE AIR CLEANER DECAL**  
ORDER #205 **\$4<sup>00</sup>**



**POWER STEERING RESERVOIR DECAL**  
ORDER #208 **\$4<sup>00</sup>**



**BLUE FLAME DECAL**  
For pass. side of valve cover.  
Use with #213 or #214.  
ORDER #207 **\$5<sup>00</sup>**



**AIR CLEANER OIL BATH DECAL**  
ORDER #201 **\$4<sup>00</sup>**



**HEATER BLOWER TUBE DECAL**  
ORDER #227 **\$5<sup>00</sup>**



**CHEV 115 HP DECAL STANDARD TRANSMISSION**  
Use with #207  
ORDER #213 **\$4<sup>00</sup>**



**CHEV 125 HP DECAL POWERGLIDE**  
Use with #207  
ORDER #214 **\$4<sup>00</sup>**



**POWER STEERING PULLEY DECAL**  
ORDER #202 **\$4<sup>00</sup>**



**RADIATOR TAG**  
ORDER #203 **\$4<sup>00</sup>**



**OIL FILTER DECAL**  
ORDER #206 **\$4<sup>00</sup>**

**GENERATOR FIELD TAG**



ORDER #204 **\$4<sup>00</sup>**

**OIL FILTER CANISTER RING**



ORDER #225 **\$5<sup>00</sup>**



**RADIATOR OVERFLOW CANISTER DECAL**  
ORDER #231 **\$5<sup>00</sup>**

**CHEVY BLUE**

Engine looking kind of sad? Freshen it up with a coat of this engine paint to make it look just like new and original.

ORDER #1313 **\$11<sup>00</sup>**



**ORANGE**

For top of Oil Filter Canister

ORDER #1382 **\$11<sup>00</sup>**



**CAST IRON ENGINE COATING**

Hi-temp paint is ideal for engine and items such as water pumps, heads and brackets. Resists heat, gas and degreaser solvents

ORDER #1383 **\$11<sup>00</sup>**

**TRIM PAINT**

Excellent for painting inner fenders, air cleaner, grill support bars, vent tubes.

ORDER #1377 **\$17<sup>00</sup>**



## PAINT





## IDENTIFY YOUR ENGINE

Ever wanted to know if the motor in your car is the original? ...  
Or just wanted to know how to identify when it was made?

Chevrolet cast the date of manufacture just above the starter, right on the engine block. (This is not the stamped numbers by the distributor, which is the engine serial number.) The cast "boss" is halfway between the pan flange and the pushrod cover, and consists of an initial (A-L = January-December) followed by three or four digits. Example: B154 equals - February 15, 1954.

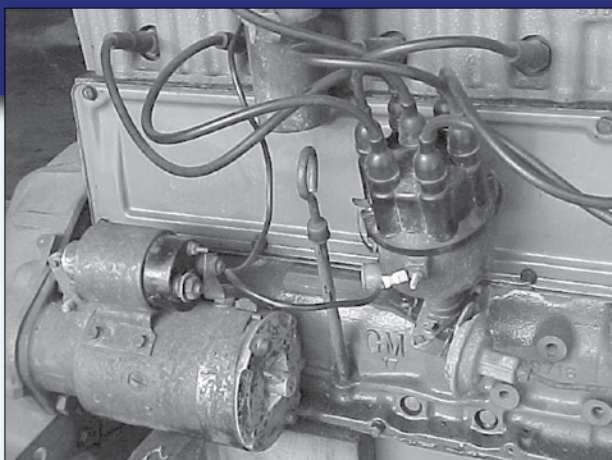

*“The Beginning”  
Our first Jefferson Show  
Spring of 1987*



## **RETURN POLICY**

Any part that is not satisfactory may be returned within **30 days** for a **full refund**. Shipping charges will not be refunded.

**ALL RETURNS** must be accompanied by a copy of the invoice or item will be sent back to you. All parts must be returned in original package in resalable condition.

If an item is defective or we made an error on your order we will reimburse your return shipping at regular ground rates. (If you order a part shipped by air, you will not be refunded the **extra** shipping cost.) If you return a part because you decided not to use it, you're responsible for the shipping charges.

**NO RETURNS AFTER 30 DAYS.**

**NO RETURNS WITHOUT A COPY OF THE INVOICE.**

Any returns after 30 days will have serious penalties and must be accompanied by a receipt.  
**CALL FIRST! 651-778-9522.**

**TECH HELP** *is available most days from 3:30 - 5:00 p.m. CST*





SEPT 1960



SEPT 1960



# 1949-50 TAIL LIGHT LENS, BEZELS, GASKETS



*Total Production  
1949 and 1950  
Approximately 2,555,698  
Average Weight 3188 lbs.*

## 1949-50 TAIL LIGHT PACKAGE



### PACKAGE INCLUDES:

- Tail Light Bezels
  - Glass Lens
  - Tail Light Gaskets
  - Tail Light Mounting Pad
- ORDER #4413-1

**SAVE \$\$**

**Only \$70<sup>00</sup>**

## 1949-50 TAIL LIGHT PACKAGE WITH BLUE DOT LENS



### PACKAGE INCLUDES:

- Tail Light Bezels
  - Blue Dot Lens
  - Tail Light Gaskets
  - Tail Light Mounting Pad
- ORDER #4413-2

**SAVE \$\$**

**Only \$104<sup>00</sup>**

## GLASS BLUE DOT TAIL LIGHT LENS

For that "custom purple glow" look.



ORDER #4406  
**\$34<sup>00</sup>** pr.

## 1950 GLASS TAIL LIGHT LENS

Not original but looks good.  
Glass lens will resist fading. While not correct, will also fit 1949.



ORDER #4405  
**\$10<sup>00</sup>**

## 1949-50 TAIL LIGHT REFLECTOR

ORDER #4407

**\$15** pr.



## 1949-50 TAIL LIGHT BEZEL

A beautiful reproduction that also includes reflector.



ORDER #4413  
**\$60<sup>00</sup>** pr.

## 1949-50 TAIL LIGHT MOUNTING PAD

ORDER #4402

**\$15<sup>00</sup>** pr.

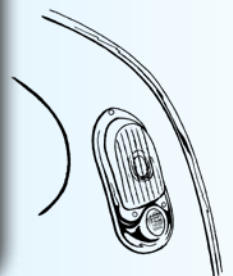



# 1951-52 TAIL LIGHT LENS, BEZELS, GASKETS



Jackson, Boise, Idaho

*Total Production  
1951 and 1952  
Approximately  
2,078,120*

## 1950-52 BACKUP LENS



Just like original.

ORDER #4416

**\$15** ea.

## 1951-52 TAIL LIGHT PACKAGE



### PACKAGE INCLUDES:

- Tail Light Bezels with Reflectors
- Tail Light Lens
- Tail Light Gaskets
- Tail Light Bezel Mounting Pads

ORDER #4431-2

SAVE \$\$

**Only \$129<sup>00</sup>**

## 1951-52 BLUE DOT TAIL LIGHT PACKAGE



### PACKAGE INCLUDES:

- Tail Light Bezels with Reflectors
- Tail Light Lens
- Tail Light Gaskets
- Blue Dot Lens

ORDER #4431-3

SAVE \$\$

**Only \$135<sup>00</sup>**

## 1951-52 TAIL LIGHT GASKET

ORDER #4429

**\$4<sup>00</sup>** ea.



## 1951-52 TAIL LIGHT REFLECTOR



ORDER #4428

**\$15<sup>00</sup>** pr.

## 1951-52 TAIL MOUNTING PAD

ORDER #4430

**\$14<sup>00</sup>** pr.



## 1951-52 GLASS BLUE DOT TAIL LIGHT LENS

For that "Purple Glo" look.

Not original.

ORDER #4435

**\$33<sup>00</sup>** pr.



## 1951-52 TAIL LIGHT BEZEL

Very nice reproduction with reflector.

ORDER #4431

**\$90<sup>00</sup>** pr.

1 only ORDER #4431-1

**\$48<sup>00</sup>**

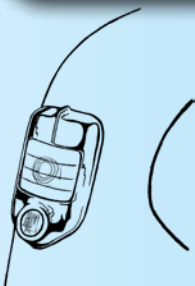

## 1951-52 GLASS TAIL LIGHT LENS

Not original but will work on both years.

ORDER #4426

**\$10<sup>00</sup>** ea.



# 1953 TAIL LIGHTS



*Total Production*  
**1953**  
*Approximately 1,356,233*  
*Richard Massey, Memphis, Tennessee*



## 1953 TAIL LIGHT PACKAGE

### PACKAGE INCLUDES:

Tail Light Bezels • Upper Lens • Center Lens  
 Back Up Lens • All Lens Gaskets • Body to Bezel Gaskets  
 ORDER #413-3

**SAVE \$\$**

**Only \$184<sup>00</sup>**



## 1953 TAIL LIGHT PACKAGE WITH BLUE DOT LENS

### PACKAGE INCLUDES:

Tail Light Bezels • Upper Lens • Blue Dot Center Lens  
 Back Up Lens • All Lens Gaskets • Body to Bezel Gaskets  
 ORDER #413-4

**SAVE \$\$**

**Only \$189<sup>00</sup>**



## TAIL LIGHT BEZELS

Beautiful reproduction chrome piece that is ready to use. Also includes installation screws.

ORDER #413-2 **\$125<sup>00</sup>** pr. #413-1 1 ONLY **\$65<sup>00</sup>**

## BLUE DOT LENS

Has best quality American dot installed.  
 Light up nice for that "purple glow".



ORDER #410

**\$28** pr.

## 1953 TAIL LIGHT LENS PACKAGE

### SET INCLUDES:

- 2 Upper Lens
- 2 Center Lens
- 2 Back-up Lens
- 4 Upper/Lower Lens Gasket
- 2 Center Lens Gasket
- 2 Body to Bezel Gasket

*All items sold separately - see list below*

REGULAR PRICE \$66.00

**PACKAGE PRICE**  
**\$71<sup>00</sup>**

Order #465



### A. UPPER LENS

Correct color - guide imprint - requires two per car. ORDER #404 **\$10<sup>00</sup>** ea.

### B. CENTER (STOP) LENS

Correct color with guide imprint. Requires two per car. ORDER #406 **\$10<sup>00</sup>** ea.

### C. BACK-UP LENS

Proper frost shade with guide imprint. Requires two per car. ORDER #408 **\$11<sup>00</sup>** ea.

### D. TAIL LIGHT AND BACK-UP LIGHT GASKET

Requires 4 per car. ORDER #401 **\$4<sup>00</sup>** ea.

### E. STOP (CENTER) LENS GASKET

Requires 2 per car. ORDER #402 **\$4<sup>00</sup>** ea.

### F. BODY TO BEZEL GASKET

Fits between tail light bezel and body of car. ORDER #414 **\$4<sup>00</sup>** ea.

## '53 INNER UPPER LENS

Replacement for broken or missing lens.  
 Excellent quality.



ORDER #415

**\$12** ea.



# 1954 TAIL LIGHTS



Wayne R. - Pennsylvania

1954 Total Production Approximately 1,147,176



**New**

## 1954 COMPLETE TAIL LIGHT ASSEMBLY

Fits right or left and includes tail light bezels, all lenses, lens divider, reflexor rings, all gaskets, 12V bulbs, sockets and backing slate.

ORDER #1947 **\$200** pr.

## 1954 TAIL LIGHT PACKAGE WITH BLUE DOT LENS



### PACKAGE INCLUDES:

- Tail Light Bezels • Upper Blue Dot Lens • Back Up Lens • Lens Dividers • Reflexor Rings • All Lens Gaskets • Body to Bezel Gaskets

ORDER #466-1

**SAVE**  
**\$\$ Only \$219<sup>00</sup>**

## 1954 TAIL LIGHT LENS PACKAGE

### PACKAGE INCLUDES:

- 2 Best Quality Upper Lens
- 2 Reflector Ring Gaskets
- 2 Best Quality Back-up Lens
- 2 Tail Light Gaskets
- 2 Reflector Rings
- 2 Body-to-Bezel Gaskets

*All lens also sold individually*

REGULAR PRICE \$80.00

**PACKAGE PRICE \$94<sup>00</sup>**  
Order #466



### A. UPPER LENS

Requires two per car.

ORDER #452ER **\$10<sup>00</sup>** ea.

### B. BACK-UP LENS

Requires two per car.

ORDER #453ER **\$10<sup>00</sup>** ea.

### C. REFLECTOR RING

Exact reproduction and excellent quality. Goes around outside of upper and lower lens. Requires two per car.

ORDER #459 **\$18<sup>00</sup>** ea.

### D. REFLECTOR RING GASKET

Goes behind ring. Requires 2 per car.

ORDER #451 **\$4<sup>00</sup>** ea.

### E. TAIL LIGHT GASKET

Goes behind lens. Requires 2 per car.

ORDER #450 **\$4<sup>00</sup>** ea.

### F. BODY TO BEZEL GASKET

Fits between tail light bezel and body of car. Requires 2 per car.

ORDER #414 **\$4<sup>00</sup>** ea.

## 1954 TAIL LIGHT BEZEL

Reproduction chrome tail light housings look great. Ready to go on your car. Just add the lens. Includes installation screws.

ORDER #458-2 **\$130** pr.  
1 ONLY #458-1 **\$67<sup>00</sup>**



# 1954 TAIL LIGHTS



## 1954 BLUE DOT LENS

For that custom "purple glow" look.

ORDER #457

**\$29<sup>00</sup>** pr.

## 1954 STAINLESS TAIL LIGHT DIVIDER



ORDER #469

**\$14<sup>00</sup>** ea.



## LEE CUSTOM FLAT LENS

One-piece custom lens that lights up in diamond pattern when brakes are applied. Looks great. Only gasket you need is body to bezel gasket. Includes installation instructions.

ORDER #460

**\$73<sup>00</sup>** pr.

## LEE CUSTOM BUBBLE LENS

Just like the other Lee Custom Lens except that it bubbles out instead of being slightly curved. Includes installation instructions.



ORDER #463

**\$80<sup>00</sup>** pr.



## REPLACEMENT LAMP PLUG

Fits 1954 upper lens and has 6" attaching wire.

ORDER #464

**\$28<sup>00</sup>** pr.

## BLUE DOTS



## BLUE DOTS

Glass blue dots you can install in your lens. For that "purple glo" custom look.

ORDER #411A

**\$9** pr.

## BOWTIE BLUE DOTS

Blue dot with a stainless cover that has a "Bow Tie" cutout. Good quality American dot used.



ORDER #2126

**\$24** pr.

*Check out our free monthly newsletter online!!!*

[www.nationalchevyassoc.com](http://www.nationalchevyassoc.com)



*Enjoy Cool Cars*

*Articles*

*Monthly Specials for Members Only*

*Monthly Contests*

*Free Classified Ads*

*New Product Updates*

*We're proud to do the newsletter for you.*

*You can also be a part of the newsletter – send pictures/stories of your car.*

*The newsletter is made up of what you, the members, send in.*

*National Chevy — still dedicated to the preservation of 1949-54 Chevys after 28 years.*



# HOOD BIRDS

## 1949 HOOD EMBLEM

Great reproduction.



ORDER #4303

**\$120<sup>00</sup>** ea.

## 1950 ACCESSORY HOOD BIRD

Quality reproduction is authentic on 1950 but fits all 1949-52 models.



ORDER #4302

**\$150<sup>00</sup>**

## 1954 HOOD BIRD

Even if you don't have a show car you still need one of these. Will make a world of difference in the appearance of your car.



ORDER #515

**\$120<sup>00</sup>**

# HOOD/TRUNK EMBLEMS & BEZELS

## 1953 HOOD EMBLEM

Replace that faded plastic with new correctly-painted plastic of excellent quality.



ORDER #301

**\$65<sup>00</sup>**

## 1950 HOOD EMBLEM

Nicely chromed, properly painted.



ORDER #4304

**\$120<sup>00</sup>**

## 1954 HOOD EMBLEM

This is a quality reproduction and correct in all ways.



ORDER #303

**\$72<sup>00</sup>**

## 1953 TRUNK EMBLEM

Excellent quality and correct in all ways.



ORDER #302

**\$68<sup>00</sup>**

## 1954 TRUNK EMBLEM

Your car will look much better with a new plastic emblem.



ORDER #304

**\$72<sup>00</sup>**

## 1954 HOOD EMBLEM AND BEZEL

This combination of plastic emblem and new metal bezel is preassembled and ready to install. If you need both pieces this is the way to do it!



ORDER #321

**\$160<sup>00</sup>**

## 1954 TRUNK EMBLEM AND BEZEL

This combination of plastic emblem metal is also preassembled and ready to install. All you need to do is bolt on this excellent quality reproduction.



ORDER #322

**\$140<sup>00</sup>**

### 1950 TRUNK WINGS FOR STD. TRANS.



Stainless replacements for those old ugly ones.

ORDER #4321

**\$48<sup>00</sup>** pr.  
*Get yours today!*

### 1949 HOOD EMBLEM RED PLASTIC INSERT



Fits 1949 accessory hood ornament.

ORDER #4301

Please call for availability

**\$90<sup>00</sup>**

## SCRIPTS

### BEL AIR SCRIPT

For '53 and '54 BelAir Models

ORDER #308-1 **\$27** ea. or #308-2 **\$50** pr.  
**'54 CHEVROLET TRUNK SCRIPT**

Fits on trunk of '54 models with standard transmission  
Not for the dash area on car.

ORDER #309 **\$30** ea.

### '54 CHEVROLET POWERGLIDE TRUNK SCRIPT

Fits on trunk of '54 models with powerglide.

ORDER #310 **\$30** ea.



### 1949-50 DELUXE FENDER SCRIPT

Chrome script for Deluxe model. Includes clips.



ORDER #4306

**\$55<sup>00</sup>** pr.

### 1952 DELUXE FENDER SCRIPT



ORDER #4323 **\$49<sup>00</sup>** pr.



### 1949-52 CHEVROLET DASH SCRIPT

ORDER #4309 **\$39<sup>00</sup>**



### 1953-54 CHEVROLET DASH SCRIPT

Fits on dash inside car. Includes fasteners

ORDER #325 **\$25<sup>00</sup>** ea.



# FRONT FENDER GRAVEL SHIELDS/MARKERS



## 1949-50 FRONT FENDER GRAVEL SHIELD

Nice stainless accessory that looks good on your car.

ORDER #4512

**\$73<sup>00</sup>** pr.



## 1951-52 FRONT FENDER GRAVEL SHIELDS

A nice stainless reproduction.

ORDER #4513

**\$110<sup>00</sup>**



## 1953-54 FRONT FENDER GRAVEL SHIELD

Nice stainless accessory. Looks good on your car!  
Includes installation instructions.

ORDER #506

**\$92<sup>00</sup>** pr.

*They're Back!*

## 1954 FRONT FENDER MARKERS



Excellent reproduction!

ORDER #508

**\$72<sup>00</sup>** pr.

# HUBCAPS/TRIM RINGS

## 1949-54 WHEEL TRIM RING UNIT



Highly polished stainless steel, 15 inches in diameter. Quick & easy to install without tools. Concave shape. Used with '53 150 or 210 series.

ORDER #538-4 **\$110** Set of 4  
ORDER #538-1 **\$35** One  
ORDER #538-2 **\$60** Pair



## 1950 SMALL HUBCAP

Stainless like original with gold paint in center.

SET OF 4  
ORDER #4535-4

**\$265<sup>00</sup>**

PAIR  
ORDER #4535-2

**\$150<sup>00</sup>**

SINGLE  
ORDER #4535-1

**\$90<sup>00</sup>**

## 1954 SMALL HUBCAP



Stainless with blue bowtie.

Fits 210 and 150 Series.

ORDER #558-4 **\$265** Set of 4

ORDER #558-1 **\$90** One

ORDER #558-2 **\$150** Pair

## 1949 SMALL HUBCAP

Stainless cap like the original with proper red paint in center.



SET OF 4  
ORDER #4524-4

**\$265<sup>00</sup>**

PAIR  
ORDER #4524-2 **\$150<sup>00</sup>**

SINGLE  
ORDER #4524-1 **\$90<sup>00</sup>**

## 1951-53 HUBCAP

Just like original.



SET OF 4  
ORDER #524-4

**\$265**

PAIR  
ORDER #524-2 **\$150**

SINGLE  
ORDER #524-1 **\$90**



## 1954 FULL DISC HUBCAP CENTER

Excellent reproduction to freshen up those original hubcaps.

ORDER #305-1

**\$25** ea.

ORDER #305-4

**\$95** Set of 4

# WHEEL HARDWARE

## METAL VALVE STEM CAP

Like the original valve stem caps.

ORDER #553

**\$8<sup>00</sup>**

Set of 4



## METAL VALVE STEM CAP (WITH CORE EXTRACTOR HEAD)

For use on spare in trunk.

ORDER #552

**\$5<sup>00</sup>** ea.



## LUG NUTS

ORDER #554

**\$6<sup>00</sup>**

Set of 5



## WHEEL STUDS

Front or rear wheel.

ORDER #555

**\$4<sup>00</sup>** ea.



## BULLET VALVE STEM COVERS

These have a sleek bullet shape and are about 1 1/4" high with a chrome finish.

ORDER #2115

**\$8<sup>00</sup>** set of 4



## TIRE VALVE STEM

With black plastic cap.

ORDER #551

**\$14**

set of 4



# DOOR HANDLES, SHIELDS, LOCK PADS

## 1949-54 DOOR HANDLE LOCK PADS

Fits between outside door handle and body of car.



2-DR. SEDAN

ORDER #1101 **\$8** set

4-DR. SEDAN

ORDER #1101-4 **\$13** set

## 1949-52 OUTSIDE DOOR HANDLES

Fits all models front or rear except rear doors on Fleetline.

ORDER #4504 **\$80<sup>00</sup>** pr.



## 1953-54 OUTSIDE DOOR HANDLES

Beautiful chrome, ready to install.

Use your lock button.

2 & 4 DOOR SEDAN ORDER #504

HARDTOP & CONVERTIBLE ORDER #504-HC

**\$100<sup>00</sup>** pr.



## 1949-54 STAINLESS DOOR HANDLE SHIELDS

Fits all '49-52 models.

ORDER #505 **\$23<sup>00</sup>** pr.



## OUTSIDE DOOR HANDLE RETAINERS

1949-52 SEDAN FRONT DOORS ORDER #4505 **\$34<sup>00</sup>** pr.

1953-54 SEDAN FRONT DOORS ORDER #572

(1953-54 retainers pictured)



## 1949-54 EXTERIOR DOOR LOCK SET

Exterior door lock set includes 2 matching keys.

2 DOOR SEDAN ORDER #583

4 DOOR SEDAN ORDER #583-4

Includes push buttons for rear doors.

**\$100<sup>00</sup>**  
**\$137<sup>00</sup>**



2 DOOR



4 DOOR



# OUTSIDE MIRRORS

Originally regarded as accessory items, mirrors are recognized today as driving essentials. These reproduction side mirrors enable you to upgrade your car to today's safety standards. The following mirrors are styled like the mirrors from the 50's and will be a nice looking addition to your car.

## DOOR EDGE MIRROR

- Die cast chrome arm — 4" stainless backed mirror.
- Fits left or right side.
- Mounts on leading edge of door, right below belt molding.

ORDER #522

**\$24<sup>00</sup>** ea.



## CHEVY STYLE MIRROR

- Die cast chrome arm 4" stainless backed mirror.
- Mounts on rain deflector on wing window.
- Left side only.
- Will not work on hardtop models.



ORDER #531  
**\$21<sup>00</sup>** ea.

## PEEP MIRROR

- Die cast chrome arm with 4" stainless backed mirror.
- Fits on top edge of door. Not for Bel Air models or hardtops and convertibles. Fits left or right side.

ORDER #532

**\$24<sup>00</sup>** ea.

## SMALL HEAD PEEP MIRROR

- A favorite of street rodders this 3" mirror has a die cast chrome arm and stainless backed mirrors.
- Fits left or right side on top edge of door.

ORDER #532SM

**\$24<sup>00</sup>** ea.



## VENT WINDOW BREEZIES

"Old fashioned air conditioning." Attach to outside of vent window and actually draw air into the car.

- |                   |              |
|-------------------|--------------|
| Red Plastic       | ORDER #2108R |
| Amber Plastic     | ORDER #2108A |
| Green Plastic     | ORDER #2108G |
| Blue Plastic      | ORDER #2108B |
| Stainless (Metal) | ORDER #2108S |
| Smoke (Gray)      | ORDER #2108K |



All priced at  
**\$16<sup>00</sup>** pr.

## BODY MOUNT MIRROR

While not a correct or original mirror, this is an excellent quality mirror that will look good on your car. Fits left or right side. Original Chevrolet mirror that was not available until 1955.

ORDER #556

**\$38<sup>00</sup>** ea.



# INSIDE MIRRORS

## 1951-52 ACCESSORY DAY/NIGHT MIRROR

Exact reproduction with chrome back, non-glare flip lever.

ORDER #4773  
**\$74<sup>00</sup>**



## 1949-50 ACCESSORY DAY/NIGHT MIRROR

Nice reproduction of GM #985994 with flip tab.

ORDER #4772 **\$69<sup>00</sup>**



## 1953-54 HARDTOP INSIDE REAR VIEW MIRROR BRACKET

Dash mount, looks great, works with day/night mirror.

ORDER #527  
**\$40<sup>00</sup>**



## 1953-54 ACCESSORY DAY/NIGHT MIRROR

Chrome back with "guide" imprint on flip knob. Fits all models.

ORDER #521  
**\$69<sup>00</sup>**



## ACCESSORY VANITY MIRROR

Clips on sunvisor. Fits all cars.

Nice reproduction.

ORDER #771  
**\$45<sup>00</sup>**



## 1949-52 INSIDE REAR VIEW MIRROR



ORDER #4771  
**\$39<sup>00</sup>**

## 1953-54 INSIDE REAR VIEW MIRROR

Has chrome back for BelAir models, but will fit all models.

Excellent quality. Bracket not included.



ORDER #728  
**\$45<sup>00</sup> ea.**



# STAINLESS MOLDING STRIPS/GRAVEL SHIELDS



## 1949-50 FRONT FENDER TRIM STRIP

Nice reproduction stainless trim strip.

Fits both sides of car. For deluxe models only.

ORDER #4517 **\$70<sup>00</sup>** ea.

## 1949-52 ROCKER MOLDING TRIM STRIP



Excellent reproduction sold in pairs only. Used on special and Deluxe models.

ORDER #4518  
\*Oversize Shipping

**\$234<sup>00</sup>** pr.

## 1951-52 DOOR MOLDING TRIM STRIP



Reproduction trim strip for Deluxe models. Fits both sides on all doors.

ORDER #4542 **\$41<sup>00</sup>**

## 1949-50 DOOR MOLDING TRIM STRIP



Stainless reproduction trim strip. Used on Deluxe models. Fits both sides of car.

ORDER #4541 **\$44** ea.

## 1949-52 ROCKER MOLDING CLIP SET



Complete set of clips to install moldings on both sides of car.

ORDER #4519 **\$53** set

## 1953-54 FRONT FENDER TRIM STRIP



Real nice reproduction, looks great on your car!

Passenger side ORDER #517-R  
Driver side ORDER #517-L

**\$60<sup>00</sup>** ea.

Fits all 210 and Bel Air Models 2- or 4-door Models

## 1953-54 DOOR MOLDING TRIM STRIP



Again an excellent reproduction that fits either side of all 210 or Bel Air 2-door models

ORDER #541

**\$50<sup>00</sup>** ea.

## 1953-54 ROCKER MOLDING TRIM STRIP



Excellent stainless reproduction! Sold in pairs only - Fits all models.

ORDER #518  
\*Oversize Shipping

**\$190<sup>00</sup>** pr.

## BELAIR PAINT DIVIDER CLIPS



Fits behind metal piece that separates rear quarter moldings on all BelAir models. Need 2 per car. 1953-54 Cars.

ORDER #1200-33 **\$14** ea.

## 1953-54 ROCKER MOLDING CLIP KIT



ORDER #617

PKG. OF 5  
**\$10<sup>00</sup>**

Not original style but will work fine. Comes with instructions and installation template. Requires 10 per car

## 1953-54 REAR GRAVEL SHIELD

Looks and fits great. Stainless like original. Includes clips.



ORDER #1946  
**\$320<sup>00</sup>** pr.

*New*

## 1953-54 "TEARDROP"

Fits 210 2 or 4 dr. Sedan. Goes above gravel shield in front of rear tire. Nice reproduction. With clips.

ORDER #1946-1  
**\$90<sup>00</sup>** pr.



# BELT MOLDING CLIP KITS

## 1949-52 2-DOOR FLEETLINE

Under windshield belt molding clip kit - driver and passenger side.

ORDER #5200-15

**\$10<sup>95</sup>**

Door belt molding clip kit

ORDER #5200-16

**\$19<sup>95</sup>**

Rear quarter belt molding clip kit - one side only

ORDER #5200-26

**\$10<sup>95</sup>**

Upper door molding clips (above glass) - does both sides

ORDER #5200-33

**\$29<sup>95</sup>**

## 1949-52 2-DOOR STYLELINE

Under windshield belt molding clip kit - driver and passenger side.

ORDER #5200-15

**\$10<sup>95</sup>**

Door belt molding clip kit

ORDER #5200-16

**\$19<sup>95</sup>**

Under rear window belt molding clip kit - driver and passenger side

ORDER #5200-27

**\$24<sup>95</sup>**

Upper door molding clips (above glass) - does both sides

ORDER #5200-33

**\$29<sup>95</sup>**

## 1950-52 HARDTOP

Under windshield belt molding clip kit - driver and passenger side.

ORDER #5200-15

**\$10<sup>95</sup>**

Door belt molding clip kit

ORDER #5200-16

**\$19<sup>95</sup>**

Under rear window belt molding clip kit - driver and passenger side

ORDER #5200-30

**\$22<sup>95</sup>**

## 1949-52 CONVERTIBLE

Under windshield belt molding clip kit - driver and passenger side.

ORDER #5200-15

**\$10<sup>95</sup>**

Door belt molding clip kit

ORDER #5200-16

**\$19<sup>95</sup>**

Under rear window belt molding clip kit - driver and passenger side

ORDER #5200-31

**\$24<sup>95</sup>**

## 1949-52 COUPE

Under windshield belt molding clip kit

ORDER #5200-15

**\$10<sup>95</sup>**

Door belt molding clip kit

ORDER #5200-16

**\$19<sup>95</sup>**

Under rear window belt molding clip kit - driver and passenger side

ORDER #5200-32

**\$22<sup>95</sup>**

Upper door molding clips (above glass) - does both sides

ORDER #5200-33

**\$29<sup>95</sup>**

## 1949-51 4-DOOR FLEETLINE

Under windshield belt molding clip kit - driver and passenger side.

ORDER #5200-15

**\$10<sup>95</sup>**

Front door belt molding clip kit

ORDER #5200-17

**\$19<sup>95</sup>**

Rear door belt molding clip kit

ORDER #5200-18

**\$19<sup>95</sup>**

Rear quarter belt molding clip kit

ORDER #5200-28

**\$8<sup>95</sup>**

Upper door molding clips (above glass) - does both sides

ORDER #5200-33

**\$29<sup>95</sup>**

## 1949-52 4-DOOR STYLELINE

Under windshield belt molding clip kit - driver and passenger side.

ORDER #5200-15

**\$10<sup>95</sup>**

Front door belt molding clip kit

ORDER #5200-17

**\$19<sup>95</sup>**

Rear door belt molding clip kit

ORDER #5200-18

**\$19<sup>95</sup>**

Under rear window belt molding clip kit - driver and passenger side

ORDER #5200-29

**\$19<sup>95</sup>**

Upper door molding clips (above glass) - does both sides

ORDER #5200-33

**\$29<sup>95</sup>**

## 1949-52 4-DOOR STATION WAGON

Under windshield belt molding clip kit - driver and passenger side.

ORDER #5200-15

**\$10<sup>95</sup>**

Front door belt molding clip kit

ORDER #5200-19

**\$19<sup>95</sup>**

Upper door molding clips (above glass) - does both sides

ORDER #5200-33

**\$29<sup>95</sup>**

## 1949-52 SEDAN DELIVERY

Under windshield belt molding clip kit - driver and passenger side.

ORDER #5200-15

**\$10<sup>95</sup>**

Front door belt molding clip kit

ORDER #5200-23

**\$19<sup>95</sup>**

Side quarter belt molding clip kit

ORDER #5200-24

**\$16<sup>95</sup>**

Rear door belt molding clip kit

ORDER #5200-25

**\$14<sup>95</sup>**

Upper door molding clips (above glass) - does both sides

ORDER #5200-33

**\$29<sup>95</sup>**

**NOTE: All clips are for one side of car unless noted. All other kits require 2 kits per door. Some clips are not reproduced exactly as originals, so we have substituted reproduction clips that work as well as originals. Instructions are included when necessary.**



# BELT MOLDING CLIP KITS

ORDER #1200 + KIT NUMBER

## 1953-1954 2 DOOR SEDAN

- Under windshield belt molding clip kit — driver and pass. side
- Door belt molding clip kit
- Under rear window belt molding clip kit — driver and pass. side

Kit #16	<b>\$16<sup>95</sup></b>
Kit #17	<b>\$13<sup>95</sup></b>
Kit #18	<b>\$32<sup>95</sup></b>

## 1953-1954 2 DOOR HARDTOP

- Under windshield belt molding clip kit — driver and pass. side
- Door belt molding clip kit
- Under rear window belt molding clip kit — driver and pass. side

Kit #16	<b>\$16<sup>95</sup></b>
Kit #19	<b>\$12<sup>95</sup></b>
Kit #20	<b>\$29<sup>95</sup></b>

## 1953-1954 2 DOOR CONVERTIBLE

- Under windshield belt molding clip kit — driver and pass. side
- Door belt molding clip kit
- Under rear window belt molding clip kit — driver and pass. side

Kit #16	<b>\$16<sup>95</sup></b>
Kit #19	<b>\$13<sup>95</sup></b>
Kit #21	<b>\$29<sup>95</sup></b>

## 1953-1954 2 DOOR COUPE

- Under windshield belt molding clip kit — driver and pass. side
- Door belt molding clip kit
- Under rear window belt molding clip kit — driver and pass. side

Kit #16	<b>\$16<sup>95</sup></b>
Kit #17	<b>\$13<sup>95</sup></b>
Kit #18	<b>\$32<sup>95</sup></b>

## 1953-1954 4 DOOR SEDAN

- Under windshield belt molding clip kit — driver and pass. side
- Front door belt molding clip kit
- Back door belt molding clip kit
- Under rear window belt molding clip kit — driver and pass. side

Kit #16	<b>\$16<sup>95</sup></b>
Kit #17	<b>\$12<sup>95</sup></b>
Kit #17	<b>\$12<sup>95</sup></b>
Kit #22	<b>\$24<sup>95</sup></b>

## 1953-1954 4 DOOR STATION WAGON

- Under windshield belt molding clip kit — driver and pass. side
- Front door belt molding clip kit
- Back door belt molding clip kit
- Back 1/4 belt molding clip kit
- Rear door belt molding clip kit

Kit #16	<b>\$16<sup>95</sup></b>
Kit #17	<b>\$13<sup>95</sup></b>
Kit #17	<b>\$13<sup>95</sup></b>
Kit #23	<b>\$13<sup>95</sup></b>
Kit #24	<b>\$13<sup>95</sup></b>

## 1953-1954 SEDAN DELIVERY

- Under windshield belt molding clip kit — driver and pass. side
- Front door belt molding clip kit
- Side 1/4 belt molding clip kit
- Rear door belt molding clip kit

Kit #16	<b>\$16<sup>95</sup></b>
Kit #17	<b>\$13<sup>95</sup></b>
Kit #25	<b>\$18<sup>95</sup></b>
Kit #26	<b>\$14<sup>95</sup></b>



## 1953-54 210 OR BELAIR REAR WINDOW UPPER CORNER STAINLESS CLIP

Fits 2 and 4 door Sedans.



ORDER  
#1200-34

**\$18** pr.



*Paul J  
Colorado*

# SIDE MOLDING CLIP KITS

## 1949-52 STATION WAGON

1949-50 Front fender molding clip kit	ORDER #5200-1	<b>\$12<sup>95</sup></b>
1951 Front fender molding clip kit	ORDER #5200-7	<b>\$14<sup>95</sup></b>
1952 Front fender molding clip kit	ORDER #5200-8	<b>\$12<sup>95</sup></b>
1949-50 Door molding clip kit	ORDER #5200-2	<b>\$10<sup>95</sup></b>
1951-52 Front door molding clip kit	ORDER #5200-10	<b>\$10<sup>95</sup></b>
1951-52 Rear door molding clip kit	ORDER #5200-11	<b>\$6<sup>95</sup></b>
1949-52 Gravel shield clip kit	ORDER #5200-6	<b>\$10<sup>95</sup></b>
1949-52 Crown molding clip kit	ORDER #5200-4	<b>\$16<sup>95</sup></b>

## 1949-50 2-DOOR FLEETLINE, STYLELINE, COUPE, HARDTOP, CONVERTIBLE

Front fender molding clip kit	ORDER #5200-1	<b>\$12<sup>95</sup></b>
Door molding clip kit	ORDER #5200-2	<b>\$10<sup>95</sup></b>
Crown molding clip kit	ORDER #5200-3	<b>\$14<sup>95</sup></b>
Gravel shield clip kit	ORDER #5200-5	<b>\$12<sup>95</sup></b>

## 1949-50 4-DOOR FLEETLINE, STYLELINE, STATION WAGON

Front fender molding clip kit	ORDER #5200-1	<b>\$12<sup>95</sup></b>
Door molding clip kit	ORDER #5200-2	<b>\$10<sup>95</sup></b>
Crown molding clip kit	ORDER #5200-4	<b>\$16<sup>95</sup></b>
Gravel shield clip kit	ORDER #5200-6	<b>\$10<sup>95</sup></b>

## 1951 2-DOOR FLEETLINE, STYLELINE, COUPE, HARDTOP, CONVERTIBLE

Front fender molding clip kit	ORDER #5200-7	<b>\$14<sup>95</sup></b>
Door molding clip kit	ORDER #5200-9	<b>\$8<sup>95</sup></b>
Gravel shield clip kit	ORDER #5200-12	<b>\$10<sup>95</sup></b>

## 1951 4-DOOR FLEETLINE, STYLELINE

Front fender molding clip kit	ORDER #5200-7	<b>\$14<sup>95</sup></b>
Front door molding clip kit	ORDER #5200-10	<b>\$10<sup>95</sup></b>
Rear door molding clip kit	ORDER #5200-11	<b>\$6<sup>95</sup></b>
Gravel shield clip kit	ORDER #5200-13	<b>\$12<sup>95</sup></b>

## 1952 2-DOOR FLEETLINE, STYLELINE, COUPE, HARDTOP, CONVERTIBLE

Front fender molding clip kit	ORDER #5200-8	<b>\$12<sup>95</sup></b>
Door molding clip kit	ORDER #5200-9	<b>\$8<sup>95</sup></b>
Gravel shield clip kit	ORDER #5200-12	<b>\$10<sup>95</sup></b>
Quarter panel molding clip kit (includes clips for short and long moldings.)	ORDER #5200-14	<b>\$14<sup>95</sup></b>

## 1952 4-DOOR STYLELINE

Front fender molding clip kit	ORDER #5200-8	<b>\$12<sup>95</sup></b>
Front door molding clip kit	ORDER #5200-10	<b>\$10<sup>95</sup></b>
Rear door molding clip kit	ORDER #5200-11	<b>\$6<sup>95</sup></b>
Gravel shield clip kit	ORDER #5200-13	<b>\$12<sup>95</sup></b>
Quarter panel molding clip kit (includes clips for short and long moldings.)	ORDER #5200-20	<b>\$14<sup>95</sup></b>

**NOTE:** All of our clip kits will install one piece of stainless. (Unless otherwise specified.) Some clips are not reproduced exactly as originals, so we have substituted reproduction clips that work as well as originals. Instructions are included when necessary.



# SIDE MOLDING CLIP PACKAGES

## **1949-50 2-DR. FLEETLINE, STYLELINE, COUPE, HARDTOP, CONVERTIBLE**

Package contains front fender clips, door molding clips, crown molding clips, gravel shield clips for both sides of car.

ORDER #5200-35

**\$74<sup>95</sup>**

## **1949-50 4-DR. FLEETLINE, STYLELINE, STATION WAGON**

Package contains front fender clips, door molding clip kits, crown molding clips, gravel shield clips for both sides of car.

ORDER #5200-36

**\$74<sup>95</sup>**

## **1951 2-DR. FLEETLINE, STYLELINE, COUPE, HARDTOP, CONVERTIBLE**

Package contains clips for front fenders, doors, gravel shields for both sides of car.

ORDER #5200-37

**\$47<sup>95</sup>**

## **1951 4-DR. FLEETLINE, STYLELINE**

Package contains door clips, fender clips, gravel shield clips for both sides of car.

ORDER #5200-38

**\$66<sup>95</sup>**

## **1952 2-DR. FLEETLINE, STYLELINE, COUPE, HARDTOP, CONVERTIBLE**

Package contains clips for front fenders, doors, gravel shield, quarter panel for both sides of car.

ORDER #5200-39

**\$70<sup>95</sup>**

## **1952 4-DR. FLEETLINE, STYLELINE**

Package includes clips for front fender, all doors, gravel shield and quarter panels for both sides of car.

ORDER #5200-40

**\$88<sup>95</sup>**

## **1953-1954 210 2-DR. SEDAN, HARDTOP, CONVERTIBLE**

Package includes front fender, door, rear quarter, gravel shield & teardrop above gravel shield.

Does complete side molding on car.

ORDER #1200-28

**\$156<sup>95</sup>**

## **1953-1954 210 4-DR. SEDAN & 4-DR. WAGON**

Package includes front fender, door, rear door, rear quarter, gravel shield and teardrop above gravel shield.

Complete package - All side molding - Both sides of car.

ORDER #1200-29

**\$145<sup>95</sup>**

## **1953-1954 BELAIR 2-DR. SEDAN, HARDTOP, CONVERTIBLE**

Package includes front fender, door, upper and lower rear quarter, V-shaped piece and gravel shield.

Clips for both sides of car.

ORDER #1200-30

**\$192<sup>95</sup>**

## **1953-1954 BELAIR 4-DR. SEDAN, 4-DR. WAGON**

Package includes front fender, front and rear doors, upper and lower rear quarter strips, gravel shields,

and "V" shaped piece for both sides of car.

ORDER #1200-31

**\$195<sup>95</sup>**

*Note: Good used stainless available.  
Check the website.*

# SIDE MOLDING CLIP KITS

ORDER #1200 + KIT NUMBER

## 1953-1954 210 2 DOOR SEDAN, HARDTOP AND CONVERTIBLE

Front fender molding clip kit	Kit #1	<b>\$16<sup>95</sup></b>
Door molding clip kit	Kit #2	<b>\$18<sup>95</sup></b>
Quarter panel molding clip kit	Kit #3	<b>\$18<sup>95</sup></b>
Trim piece above gravel shield	Kit #13	<b>\$8<sup>95</sup></b>
Gravel shield clip kit — does both sides	Kit #14	<b>\$29<sup>95</sup></b>

## 1953-1954 210 4 DOOR SEDAN AND 4 DOOR WAGON

Front fender molding clip kit	Kit #1	<b>\$16<sup>95</sup></b>
Front door molding clip kit	Kit #4	<b>\$16<sup>95</sup></b>
Rear door molding clip kit	Kit #5	<b>\$14<sup>95</sup></b>
Quarter panel molding clip kit	Kit #6	<b>\$14<sup>95</sup></b>
Trim piece above gravel shield	Kit #13	<b>\$8<sup>95</sup></b>
Gravel shield clip kit/both sides	Kit #14	<b>\$29<sup>95</sup></b>

## 1953-1954 BEL AIR 2 DOOR SEDAN, HARDTOP AND CONVERTIBLE

Front fender molding clip kit	Kit #1	<b>\$16<sup>95</sup></b>
Door molding clip kit	Kit #2	<b>\$18<sup>95</sup></b>
Quarter panel molding clip kit — top strip	Kit #7	<b>\$19<sup>95</sup></b>
Quarter panel molding clip kit — bottom strip	Kit #8	<b>\$16<sup>95</sup></b>
Quarter panel molding end piece	Kit #9	<b>\$8<sup>95</sup></b>
Gravel shield clip kit — does both sides	Kit #14	<b>\$29<sup>95</sup></b>

## 1953-1954 BEL AIR 4-DOOR SEDAN AND 4 DOOR WAGON

Front fender molding clip kit	Kit #1	<b>\$16<sup>95</sup></b>
Front door molding clip kit	Kit #4	<b>\$16<sup>95</sup></b>
Rear door molding clip kit — top and bottom strip	Kit #10	<b>\$18<sup>95</sup></b>
Quarter panel molding clip kit — top strip	Kit #11	<b>\$13<sup>95</sup></b>
Quarter panel molding clip kit — bottom strip	Kit #12	<b>\$14<sup>95</sup></b>
Quarter panel molding end piece	Kit #9	<b>\$8<sup>95</sup></b>
Gravel shield clip kit/both sides	Kit #14	<b>\$29<sup>95</sup></b>





# GRILL HARDWARE KITS



## 1949-50 GRILL ASSEMBLY KIT

Rivets are replaced with stainless steel nuts and bolts.

ORDER #5901 **\$30<sup>00</sup>**

## 1951-52 GRILL ASSEMBLY KIT

Rivets are replaced with steel nuts and bolts.

ORDER #5903 **\$20<sup>00</sup>**



## 1949-50 GRILL TO CAR INSTALLATION KIT

ORDER #5902 **\$17<sup>00</sup>**

## 1951-52 GRILL TO CAR INSTALLATION KIT

ORDER #5904 **\$12<sup>00</sup>**



## 1953 GRILL ASSEMBLY KIT

(Rivets are replaced with stainless nuts and bolts)

ORDER #1908 **\$30<sup>00</sup>**



## 1954 GRILL ASSEMBLY KIT

(Rivets are replaced with stainless nuts and bolts)

ORDER #1907 **\$30<sup>00</sup>**



## GRILL TO CAR INSTALLATION KIT

1953 ORDER #1910 **\$16**

1954 ORDER #1909 **\$16**



## 1953 SPLASH PAN ANTI RATTLE U-SEAL CAP

(Fits on front bumper braces under front splash pan of '53 Chev)

ORDER #601-20 **\$8<sup>00</sup>**

## Questions

- 1) How much did a gallon of milk cost in 1953?
- 2) How much did a gallon of gas cost in 1953?
- 3) What new innovation makes a gross profit \$1.25 billion in just the United States?

## Answers

- 1) 94 cents/gallon
- 2) 20 cents/gallon
- 3) Vending Machine



*Camba  
Scene  
from  
Florida*

# 1949-52 BUMPERS, BUMPER BOLTS, BUMPER BOLT KITS

## 1949-52 FRONT 1-PIECE BUMPER



Chromed and ready to install!

ORDER #6482  
\*Oversize Shipping

**\$425<sup>00</sup>**

## 1949-52 REAR 1-PIECE BUMPER

Just like the front — ready to go



ORDER #6483  
\*Oversize Shipping

**\$425<sup>00</sup>**

## HIGH DOME BUMPER BOLT

Original bumper bolt used on cars.  
Chrome finish.

ORDER #520HD

**\$5<sup>00</sup>** ea.



## 1/2" POLISHED STAINLESS CAP BUMPER BOLT

ORDER #520 **\$4<sup>00</sup>** ea.



## FRONT OR REAR BUMPER BOLT KIT

Uses replacement 1/2" stainless capped bolt.  
Bolt is not stainless.

ORDER #1917

**\$14<sup>00</sup>** ea.



## FRONT OR REAR BUMPER BOLT KIT

Uses original high dome bolt.

ORDER #1904

**\$22<sup>00</sup>**



## 1949-52 FRONT BUMPER ASSEMBLY KIT

ORDER #5905

**\$29<sup>00</sup>**

## 1949-52 REAR BUMPER ASSEMBLY KIT

ORDER #1902

**\$29<sup>00</sup>**



## 1949-52 FRONT BUMPER ASSEMBLY KIT

Uses replacement 1/2" steel bolt with stainless cap.

ORDER #5905-1

**\$24<sup>00</sup>**

## REAR BUMPER ASSEMBLY KIT

ORDER #1919

**\$24<sup>00</sup>**



## REAR BUMPER ARM GROMMETS

ORDER #4601-9

**\$11<sup>00</sup>** pr.



## FRONT SPLASH PAN PLUG

ORDER #4601-10

**\$8<sup>00</sup>** pr.



## 1949-50 FRONT LICENSE POCKET GUARD

Excellent reproduction.



ORDER #4540

**\$160<sup>00</sup>**



# 1953-54 BUMPERS, BUMPER BOLTS, BUMPER BOLT KITS

## 1953 1-PIECE FRONT BUMPER

Chrome plated, excellent quality  
- ready to install.

ORDER #482



**\$425<sup>00</sup>**

\*Oversize Shipping

## 1954 1-PIECE FRONT BUMPER

Ready to install.

ORDER #483

**\$425<sup>00</sup>**

\*Oversize Shipping



## 1953 or 1954 1-PIECE REAR BUMPER

Chromed and ready to install.

ORDER #484



**\$425<sup>00</sup>**

\*Oversize Shipping



## 1/2" HIGH DOME CHROME BUMPER BOLT

Original bumper bolt used on cars.  
Chrome finish.

ORDER #520 HD

**\$5<sup>00</sup>** ea.



## 1/2" POLISHED STAINLESS CAP BUMPER BOLT

ORDER #520 **\$4<sup>00</sup>** ea.



## FRONT OR REAR BUMPER BOLT KIT

Uses original high dome bolt.

ORDER #1904

**\$24<sup>00</sup>**



## FRONT OR REAR BUMPER BOLT KIT

Uses replacement 1/2" stainless capped bolt. Bolt is not stainless.

ORDER #1917

**\$14<sup>00</sup>**

## 1953 OR 1954 FRONT BUMPER ASSEMBLY KIT

ORDER #1902

**\$29<sup>00</sup>**



## 1953 - 1954 REAR BUMPER ASSEMBLY KIT

ORDER #1901

**\$29<sup>00</sup>**

## 1953-1954 FRONT CLIP ASSEMBLY KIT

Contains all bolts, nuts, washers, etc. to reassemble front clip. (Fenders, inner fenders)

ORDER #1905

**\$29<sup>00</sup>**



## 1953 OR 1954 FRONT BUMPER ASSEMBLY KIT

Uses replacement 1/2" stainless capped bolt. Bolt is not stainless.

ORDER #1918

**\$24<sup>00</sup>**



## 1953 OR 1954 REAR BUMPER ASSEMBLY KIT

Cap only assembly kit.

ORDER #1919

**\$24<sup>00</sup>**



Jim Iowa

# FRONT LICENSE PLATE BRACKETS

## 1949-50 FRONT LICENSE PLATE BRACKET

Excellent reproduction with glossy black finish.

ORDER #4501 **\$20<sup>00</sup>**

Fits 1949s with pocket guard, and all 1950s.



## 1951-52 FRONT LICENSE PLATE BRACKET

Another excellent reproduction!

ORDER #4502 **\$19<sup>00</sup>**



## 1953-54 FRONT LICENSE PLATE BRACKET

Excellent Reproduction with glossy black finish.

ORDER #501 **\$16<sup>00</sup>**



# PARK LIGHT LENS & GASKETS

## 1951 PARK LIGHT ASSEMBLY



with 12V bulb and housing. Park and flasher circuit. Includes lens.

ORDER #4446 **\$140<sup>00</sup>** Ea.



## 1951 PARK LIGHT LENS

ORDER #4441 **\$11<sup>00</sup>** ea.

## 1952 PARK LIGHT LENS

ORDER #4442 **\$12<sup>00</sup>** ea.



## 1951 PARK LIGHT LENS GASKET

ORDER #4443 **\$5<sup>00</sup>** ea.

## 1952 PARK LIGHT LENS GASKET

ORDER #4444 **\$5<sup>00</sup>** ea.

# LICENSE LIGHT PAD / GASKETS

## 1949-50 LICENSE LIGHT MOUNTING PAD

ORDER #4411



**\$10** pr.

## 1949-50 LICENSE LIGHT LENS GASKET

ORDER #4412



**\$5<sup>00</sup>** ea.

## 1951-52 LICENSE LIGHT LENS GASKET

ORDER #4432



**\$5<sup>00</sup>** ea.



# PARK LIGHT LENS AND GASKETS

## 1953 PARK LIGHT LENS



Nice glass reproduction.

Requires 2 per car.

ORDER #412

**\$11<sup>00</sup>** ea.

## 1953 PARK LENS BEZEL

Great stainless reproduction to replace those old dented ones.

ORDER #430

**\$14<sup>00</sup>**



## 1953 PARK LIGHT GASKET



Use with new park light lens.

Requires 2 per car.

ORDER #409

**\$4<sup>00</sup>** ea.

## 1954 PARK LIGHT BEZEL

New bezels to compliment those new or re-chromed housings.

ORDER #514

**\$50<sup>00</sup>** pr.



## 1954 PARK LIGHT LENS

Excellent reproduction in proper white frost shade.

Requires 2 per car.

ORDER #454

**\$12<sup>00</sup>** ea.



## AMBER 1954 PARK LIGHT LENS

For a mild custom look.

ORDER #455

**\$11<sup>00</sup>** ea.



## 1954 PARK LIGHT GASKET

To be used behind new lens.

Requires 2 per car.

ORDER #456

**\$4<sup>00</sup>** ea.

# GRILL PARTS

## 1954 PARK LIGHT HOUSING

Compliment that newly-plated grill with these excellent looking housings.



ORDER #513

**\$255<sup>00</sup>** pr.

## 1953 GRILL EXTENSION

Beautiful reproduction of the original. Chromed and ready to install.

ORDER #418

**\$239<sup>00</sup>**



# GRILL PARTS

## 1949 UPPER GRILL BAR



Very nice reproduction.  
Ready to install.

ORDER #1951 **\$299<sup>00</sup>**

## 1949 LOWER GRILL BAR



Very nice.  
Ready to install.

ORDER #1954 **\$299<sup>00</sup>**

## 1949 CENTER GRILL BAR

Nice and ready to install.

ORDER #1954L  
**\$299**

## 1953 GRILL BARS

**\$299<sup>00</sup>** ea.



**Upper Grill Bar**  
ORDER #1942



**Center Grill Bar**  
ORDER #1942C



**Lower Grill Bar**  
ORDER #1942L

## 1954 GRILL TEETH

Very nice reproduction.

ORDER #1937  
*Only* **\$375** set



## 1954 GRILL BARS

**Center Grill Bar**  
ORDER #1936

**\$299** ea.



**Upper Grill Bar**  
ORDER #1943

**\$299** ea.



## 1953 GRILL TEETH

Excellent reproduction.

Set of 3  
ORDER #1941  
*Only* **\$375** set





# LICENSE PLATE FRAMES AND FASTENERS

## CHROME LICENSE PLATE BULLETS

ORDER #2104



**\$8<sup>00</sup>** set of 4

Used to hold on license plate frames.

## LICENSE PLATE REFLECTORS

American-made,  
excellent quality.



BLUE ORDER #2105B  
GREEN ORDER #2105G  
AMBER ORDER #2105A

**\$2<sup>00</sup>** ea.

## CHROME LICENSE PLATE FRAME

Just plain chrome, good finish, looks good.



ORDER #560

**\$8<sup>00</sup>** ea.

## Phone Us

651-778-9522

## Fax Us

1-800-785-5354

## Mail Us

National Chevy Association  
947 Arcade  
St. Paul, MN 55106

## Website

[www.nationalchevyassoc.com](http://www.nationalchevyassoc.com)

## Email Us

[info@nationalchevyassoc.com](mailto:info@nationalchevyassoc.com)

NOTE: Tech questions must be phoned in.  
They will not be answered by email.

*Don't forget to check  
out our website for  
used parts at  
[www.nationalchevyassoc.com](http://www.nationalchevyassoc.com)*

# 1949-54 FENDER SKIRTS

## 1949-50 FENDER SKIRTS

Excellent reproduction of original.  
Fits good and new skirt rubber is also included.

ORDER #6498



## 1951-52 FENDER SKIRTS

Another excellent metal fender skirt.  
Also includes fender skirt rubber seal.

ORDER #6498-1



## 1949-54 FENDER SKIRT RUBBER

ORDER #813 **\$14<sup>00</sup>** pr.



## 1949-54 FENDER SKIRT BRACKETS

Required for metal skirts. For front opening of rear wheel well.

ORDER #543 **\$19<sup>00</sup>** pr.



### NOTE

We have some good used metal skirts.  
Call for price and availability.



## 1953-54 FENDER SKIRTS

Metal fits well and  
includes rubber seals.

\* Metal skirts require brackets which  
are sold separately.

Metal (original)  
ORDER #542



### NOTE

Please call for availability on all fender skirts.



# HORN PARTS

## 1953-54 HORN BUTTONS

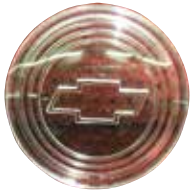

Clear plastic with bowtie.  
Can be painted to match your car.

**1953 ORDER #317**

**\$25<sup>00</sup>**



Clear plastic with insignia. Can be painted to match your car.

**1954 ORDER #318**

**\$25<sup>00</sup>**

## 1951 HORN BUTTON



ORDER #4324

**\$36<sup>00</sup>**

## 1949-50 HORN RING

*New & Nice*



ORDER #4317

**\$129<sup>00</sup>**

# SHIFT KNOBS / DASH KNOBS

## GEAR SHIFT KNOBS



**1949 STD. TRANSMISSION**

Tan

ORDER #4754

**\$20<sup>00</sup>**



**1950 STD. TRANSMISSION**

Gray

ORDER #4754-1

**\$20<sup>00</sup>**



**1951-52 STD. TRANSMISSION**

Ivory

ORDER #4754-2

**\$20<sup>00</sup>**



**1950-52 POWERGLIDE TRANSMISSION**

ORDER #4754-3

**\$23<sup>00</sup>**

## 1953-54 STANDARD TRANSMISSION SHIFT LEVER KNOB

ORDER #754

**\$23<sup>00</sup>**



# TURN SIGNAL/SHIFT COLLAR

## 1949-54 GEAR SHIFT COLLAR

ORDER #718

**\$21<sup>00</sup>**



## 1949-54 STEERING COLUMN TO DASH SEAL

ORDER #601-22

**\$8<sup>00</sup>**



# HORN AND STEERING WHEEL PARTS



## 1953-54 MOUNTING SCREW INSULATORS

Insulates mounting screws and spaces horn ring. Set of 3 required.

ORDER #324 **\$12<sup>00</sup>** set

## 1953-54 HORN RING

Chrome plated and ready to install. Much nicer than that bent, pitted one



ORDER #316 **\$79<sup>00</sup>**

## 1949-54 HORN CONTACT SPRING

Fits in center of horn



ORDER #319 **\$15<sup>00</sup>**

## 1949-52 PLASTIC HORN RING SPACER

ORDER #4328 **\$28<sup>00</sup>**



# HORN PARTS

### NOTE:

Horn Plastic Ring Spacer (goes under ring) and Horn Ring Spring (large metal ring that goes under plastic ring spacer) are available used.

Call for availability and price.

## 1949-54 HORN CONTACT INSULATING SLEEVE



Spring goes inside of this sleeve.

ORDER #320 **\$9<sup>00</sup>**

## 1949-54 UPPER STEERING COLUMN BEARING

ORDER #1469

**\$60** ea.



## 1949-54 HORN RELAY

Even these wear out after 40 years. Replace it with a new one.

ORDER #1317

**\$40<sup>00</sup>**





# TURN SIGNAL



## 1949-52 TURN SIGNAL ASSEMBLY

Not original but this heavy duty unit works good.  
Nice chrome finish with instructions.

ORDER #4758 **\$35<sup>00</sup>**

## 1949-54 TURN SIGNAL SWITCH HOUSING WEDGE



ORDER #786

**\$9<sup>00</sup>**

## 1949-54 COLUMN SHIFT LEVER RETAINER KIT

ORDER #709  
**\$28<sup>00</sup>**



## 6V TURN SIGNAL FLASHER

Turn signal problems? Try a new flasher.



1949-54 Cars  
ORDER #1358

**\$19<sup>00</sup>**

# DASH KNOBS

## HEADLIGHT SWITCH KNOB

Nice reproduction. Correct color.



1949  
ORDER #4737-49

1950  
ORDER #4737-50

1951-52  
ORDER #4737-1

**\$20<sup>00</sup>** ea.

Charles Stephenson  
1950 Chevy Deluxe Coupe



*Charles  
1950 Chevy  
Deluxe Coupe*

# RADIOS/RADIO PARTS

## 12 VOLT RADIO

Looks just like the original, but plays much better and offers more music choices. Also includes speakers.

1951-52 - ORDER #6499

1953-54 - ORDER #6499-1

**\$748<sup>00</sup>**



## RADIO ANTENNA

Excellent reproduction that is just like original. Comes complete with mounting parts and antenna wire.

1949-52 ORDER

#5544

1953-54 ORDER

#544

**\$110<sup>00</sup>**



## 1949-54 VIBRATOR TUBE

This is the tube most often asked for. The original mechanical vibrator tube used points similar to what was used in ignition system. These are subject to wear, pitting and oxidation. Vibrator gets its name from metal armature that vibrates to open and close points. The hum you hear when you turn on the radio is a result of this action. Solid state vibrator has no moving parts so it is silent in operation and lasts for years.

ORDER #794

**\$50<sup>00</sup>**





# RADIO GLASS

## 1953-'54 MANUAL TUNE RADIO GLASS



ORDER #736

**\$28<sup>00</sup>**

## 1953-'54 PUSH BUTTON RADIO GLASS



ORDER #735

**\$28<sup>00</sup>**

# GLOVE BOX

## 1949-54 GLOVE BOX LOCK



ORDER #323

**\$37<sup>00</sup>**

## 1949-54 GLOVE BOX GROMMET



This is the little rubber bumper for the glove box door to close against.

ORDER #601-8

**\$3<sup>00</sup>** pr.

## 1953-54 GLOVE BOX

Great Reproduction - Just Like Original. Includes hardware.

ORDER #314

**\$28<sup>00</sup>**



## 1949-50 GLOVE BOX

Excellent reproduction.

ORDER #4314

**\$28<sup>00</sup>**



## 1951-52 GLOVE BOX

Excellent!

ORDER #4314-1

**\$28<sup>00</sup>**



## TRAFFIC LIGHT VIEWER



Optically clear prism viewer is mounted to dash board and lets driver see overhead traffic lights especially when blocked by outside sunvisor.

Great accessory.

ORDER #510

**\$55<sup>00</sup>**

## 1953-54 TISSUE DISPENSER

Has a beautiful chrome front panel with Chevy Bowtie in center. Easily mounts under dash and comes with tissues.

Great accessory!

ORDER #519

**\$90<sup>00</sup>**



# INTERIOR PARTS



## 1953-54 REAR ASHTRAY INSERT

(HARDTOP/CONVERTIBLE)  
ORDER #730

**\$30<sup>00</sup>** pr.

## 1950-54 ASHTRAY SLIDE COVER

Fits in rear qtr. armrests of hardtops and convertibles. Use with ashtray inserts.

ORDER #732 **\$60<sup>00</sup>** pr.



## 1949-52 SEAT KNOB

Beautiful American-made reproduction.

ORDER #4759

**\$32<sup>00</sup>**

## 1953-54 CHEVROLET DASH SCRIPT

This is the script that goes on the dash. Very nice reproduction that is ready to install. Installation instructions included.

ORDER #325

**\$24<sup>00</sup>**



## 1949-50 SPEEDO GLASS

ORDER #4329

**\$44<sup>00</sup>**

## GEAR INDICATOR NEEDLE FOR POWERGLIDE TRANSMISSION

Includes installation instructions.

ORDER #326

**\$35<sup>00</sup>**



## DASH GLASS

30# for all 1953 standard transmissions. Excellent reproduction.

ORDER #734

**\$39<sup>00</sup>**



## 1949-50 DASH SCRIPT

"CHEVROLET"

ORDER #4309

**\$33<sup>00</sup>** ea.



## DASH GLASS

60# for all 1954 and 1953 powerglide.

ORDER #733

**\$39<sup>00</sup>**



*Rick & Sue, Illinois*

*Dedicated to the  
Preservation, Pleasure and Pride in  
1949-54 Chevrolets*



# INTERIOR PARTS



**1953-54 WING WINDOW CRANK HANDLE**  
Same quality as other handles and includes mounting clip.

ORDER #723  
**\$10<sup>00</sup>** ea.

**1953-54 WINDOW CRANK HANDLE**

Original design with glossy black plastic knob and excellent chrome plating. Mounting clip included.

ORDER #724 **\$10<sup>00</sup>** ea.

**1953-54 INSIDE DOOR HANDLE**

Excellent reproduction. Just like original and comes with mounting clip

ORDER #725 **\$10<sup>00</sup>** ea.

**1949-52 INSIDE DOOR HANDLE**

Excellent reproduction that is just like original.  
Includes mounting clip.



ORDER #725  
**\$10<sup>00</sup>** ea.

**1949-52 VENT WINDOW HANDLE**

Fits front or rear doors on all Styleline or Fleetline 2 or 4 door Sedans.

Dr. Side Door  
ORDER #4607L  
Pass. Side Door

ORDER #4607R  
**\$29<sup>00</sup>** ea.



**WINDOW AND VENT WINDOW CRANKS**

Custom knob - good for use in custom or original.



WINDOW CRANK  
ORDER #2152  
WING WINDOW CRANK  
ORDER #2153  
**\$10<sup>00</sup>** ea.

**1953-54 INSIDE DOOR HANDLE REMOVAL TOOL**



Removes horseshoe-shaped handle clip.  
Makes handle removal a snap.  
Fits many other makes also.

ORDER #713  
**\$14<sup>00</sup>** ea.

**RETAINER WASHER**

Fits between door handle and door panel. Original was metal, reproduction is plastic.

ORDER #751  
**\$3<sup>00</sup>** ea.



**1949-52 INSIDE DOOR HANDLE REMOVAL PLIER**



Removes horseshoe-shaped handle clip.  
Makes handle removal a snap.

ORDER #4713  
**\$18<sup>00</sup>**

**TENSION SPRING**

Used to maintain a firm seal between inside door handle and door panel.

ORDER #715 **\$2<sup>00</sup>** ea.



**HORSESHOE CLIP**

Metal retainer that holds inside door handles on.

ORDER #714 10 for **\$3<sup>00</sup>**



# INTERIOR PARTS

## 1949-54 SEDAN DOME LIGHT RIM



Beautiful chrome just like original for use with sedan dome lens.

ORDER #315  
**\$24<sup>00</sup>**

## 1949-54 SEDAN DOME LIGHT COVER



Excellent quality reproduction in correct color.

Fits 1949-52 Sedans - 2- or 4-dr., wagons.

ORDER #311  
**\$19<sup>00</sup>**

## 1949-52 CONVERTIBLE DOME LIGHT LENS



Excellent quality, correct color.

ORDER #4520  
**\$22<sup>00</sup>**

## 1950-52 HARDTOP DOME LIGHT LENS



Excellent quality, correct color. Requires 2 per car.

ORDER #4516  
**\$20<sup>00</sup> ea.**

## 1949-52 CONVERTIBLE DOME LIGHT RIM



Just like the original

ORDER #4521  
**\$20<sup>00</sup>**

## 1953-54 HARDTOP DOME LIGHT HOUSING



Replace those old pitted housings with these nice new ones. Requires 2 per car.

ORDER #787 **\$49<sup>00</sup> ea.**

## 1953-54 HARDTOP DOME LIGHT LENS



Just like original in correct color. Requires 2 per car.

ORDER #313  
**\$5<sup>00</sup> ea.**

## 1949-54 COAT HOOKS



Add detail to your car with these excellent new coat hooks.

ORDER #729  
**\$15<sup>00</sup> pr.**

## 1949-54 DOME LIGHT SWITCH



Replace broken dome light switches. Fits all models.

ORDER #753  
**\$28<sup>00</sup> ea.**

## DOOR LOCK BUTTONS

Just like original quality. Fits both years.

BLACK	#722-1
RED	#722-2
TURQUOISE	#722-3
GREEN	#722-4
YELLOW	#722-5
BLUE	#722-6
BROWN	#722-7
DK. GRAY	#722-8



**\$12<sup>00</sup> pr.**

## 1949-54 DOME LIGHT SWITCH GASKET

Rubber gasket that fits between body and switch.



ORDER #1006

**\$4<sup>00</sup> pr.**



# HARDTOP/CONVERTIBLE WINDLACE CORES

## 1953-54 WINDLACE INNER CORE WITH END STOPS



This is used on hardtop & convertible and needs to be covered with vinyl

ORDER #1036  
**\$23<sup>00</sup>** pr.

## 1953-54 HARDTOP AND CONVERTIBLE WINDLACE

In original vinyl - ready to use.



Color samples available.

ORDER #744  
**\$125<sup>00</sup>** set

## 1953-54 WINDLACE END STOPS



If your windlace is in good shape and you just need to replace the end stops - this is what you need. Also includes installation instructions.

ORDER #1037  
**\$11<sup>00</sup>** pr.

## HEADLINER TOOL



Pushes headlining in channel above doors. Easy to use around curves and corners.

ORDER #770  
**\$19<sup>00</sup>**

## 1949-54 TACK STRIP

Some tack strip may be needed when installing a new headliner and windlace. Sold by the foot. Measure what you need and order it.



ORDER #752  
**\$4<sup>00</sup>** ft.  
3/16" x 1/2"



ORDER #765  
**\$4<sup>00</sup>** ft.  
1/8" x 5/8"

# SUNVISORS

## 1949-54 CUSTOM SUNVISOR

These are included in custom interior kit, but can be purchased separately. Send your cores for recovering. Be sure to let us know what color you want.

ORDER #797  
**\$139<sup>95</sup>** pr.



## 1949-54 SEDAN SUNVISORS

All New Sunvisor — Board, rod and cloth. Excellent quality replacement. Should be ordered with headliner so all fabric matches. Specify color.

1949-52 ORDER #5740  
1953-54 ORDER #782

**\$190<sup>00</sup>** pr.



# HEADLINERS

## HEADLINERS

For 2 and 4 door sedans, sedan delivery, station wagons, business, club coupes and hardtops. Available in original brushed cotton style fabric. All pre-sewn and ready to install. Includes sunvisor fabric and installation instructions. Sold by year and model (ex. 53 210 4 dr. sedan). Color samples available. Available in tan, light blue, light green, light gray, turquoise, black, red, maroon and taupe.

When ordering headliner we need YEAR, MODEL, BODY STYLE AND COLOR.

HARDTOP HEADLINER AVAILABLE IN VINYL.

### 1949-52

2 dr. Fleetline	ORDER #5739-2F	\$399 <sup>00</sup>
2 dr. Styleline	ORDER #5739-2S	\$399 <sup>00</sup>
4 dr. Fleetline	ORDER #5739-4F	\$399 <sup>00</sup>
4 dr. Styleline	ORDER #5739-4S	\$399 <sup>00</sup>
Coupe	ORDER #5739-2C	\$399 <sup>00</sup>
Hardtop	ORDER #5739-H	\$428 <sup>00</sup>
Sedan Delivery	ORDER #5739-SD	\$419 <sup>00</sup>
Station Wagon	ORDER #5739-SW	\$419 <sup>00</sup>

### 1953-54

2 dr. Sedan, BA, 210, 150	ORDER #739-2	\$399 <sup>00</sup>
4 dr. Sedan, BA, 210, 150	ORDER #739-4	\$399 <sup>00</sup>
Club Coupe	ORDER #739-CC	\$399 <sup>00</sup>
Business Coupe	ORDER #739-BC	\$399 <sup>00</sup>
Hardtop	ORDER #739-H	\$425 <sup>00</sup>
Station Wagon	ORDER #739-SW	\$419 <sup>00</sup>
Sedan Delivery	ORDER #739-SD	\$419 <sup>00</sup>



PLEASE NOTE: We try to stock all headliners but may run out. Please allow 2 weeks for delivery.

## WINDLACE

### 1949-54 SEDAN

Cloth covered replacement for use in sedan models. Windlace should be replaced when new headliner is installed. Color samples available. Sold in sets.

2 dr. sedan, sedan delivery,  
business or club coupe

4 dr. sedan

ORDER #741

ORDER #742

\$100 set

\$189 set



## WINDLACE SEWING SERVICE

Windlace is pre-sewn to factory specs for easy installation.

Available in tan, light blue, light green, light gray, turquoise, black, red, maroon and taupe.

<b>1949-52 2 DR. SEDAN</b>	\$179 <sup>00</sup>
ORDER #5741-PS	
<b>1949-52 2-DR. COUPE</b>	\$179 <sup>00</sup>
ORDER #5744-PS	
<b>1949-52 4 DR. SEDAN</b>	\$219 <sup>00</sup>
ORDER #5742-PS	
<b>1950-52 HARDTOP</b>	\$119 <sup>00</sup>
ORDER #744-2 Cloth or Vinyl	
<b>1953-54 2 DR. SEDAN</b>	\$179 <sup>00</sup>
ORDER #741 PS	
<b>1953-54 SEDAN DELIVERY</b>	\$179 <sup>00</sup>
ORDER #741 PS-SED. DEL.	
<b>1953-54 HARDTOP</b>	\$119 <sup>00</sup>
ORDER #744 Cloth or Vinyl	
<b>1953-54 4 DR. SEDAN</b>	\$219 <sup>00</sup>
ORDER #742 PS	





# CARPET MATS & ACCESSORIES

## 1949-54 CARPET MATS

Loop or cut pile carpet mats that will match your carpet set. Can also be used in any car as a mat. All colors above available. Sold in sets of 4.

ORDER #707-24

**\$49<sup>00</sup>** SET OF 4

*Specify color and carpet style.*



## SPRAY ADHESIVE

Large 18-oz. can of spray adhesive.

ORDER #721

**\$14<sup>00</sup>**



## ACCELERATOR PEDAL AND DIMMER SWITCH GROMMET

1949-54 Cars

ORDER #710 **\$15<sup>00</sup>**



*Bob R., Minnesota*

# GARNISH MOLDING SCREW KITS

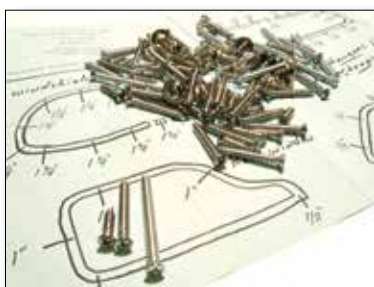

## 1949-52

- 2 Door Styleline Sedan ORDER #4701-1
- 4 Door Styleline Sedan ORDER #4701-2
- 2 Door Fleetline Sedan ORDER #4701-3
- 4 Door Fleetline Sedan ORDER #4701-4
- 2 Door Coupe ORDER #4701-5
- 2 Door Hardtop ORDER #4701-6
- Convertible ORDER #4701-7
- Sedan Delivery ORDER #4701-8

## 1953-54

- 2 Door Sedan Trim Kit ORDER #701-1
- 2 Door Hardtop Trim Kit ORDER #701-2
- Convertible Trim Kit ORDER #701-3
- 4 Door Sedan Trim Kit ORDER #701-4
- Station Wagon Trim Kit ORDER #701-5
- Business Coupe Trim Kit ORDER #701-6
- Sedan Delivery Trim Kit ORDER #701-7

Enhance those freshly-painted garnish moldings with bright new chrome-plated screws. Includes screws for door panels, seats and coat hangers too. Placement diagram included.

**\$19<sup>00</sup>** ea.

**NOTE:** Used interior garnish moldings are available for most models. Call for price and availability.

# MEET THE NCA CREW

Continued from Page 14



## MEET ADAM

Adam has been at NCA for about 16 years. He takes phone orders, pulls orders and ships packages when at work. In his free time, Adam plays an upright bass in a band called "The Reckless Ones" and they perform Rockabilly. Last summer they did some shows in Europe. He also works on his '52 Chevy 4-door, which has a 350 Chevy engine in it.



## MEET THERESE

Therese has worked for NCA for 6 years. She works in our Interior Dept. Sewing has been a life long skill with many years of reupholstering furniture and seamstress work. In her off time, she enjoys golfing and loves spoiling her grandchildren.

## MEET JEFF

Jeff has been at NCA for about 20 years, first as part-time, now as full-time. He is our jack-of-all-trades. In his spare time, Jeff works on his '29 Model A and his '29 Ford Roadster. He also enjoys auctions, especially if they have old car parts and a few antiques.



Not shown are Vic, Bonifacio, Joe, Butch, Julian, Joe from our warehouse and Interior Staff.



# CARPET

## ORIGINAL CARPET

Carpet is sewn just like original carpet with sewn hump binding and vinyl heel pad. Open on sides for easy installation up to sill plates. Pad is also cut for easy installation. Carpet and pad should be glued down for a nicer look. Available in red, black, brown, tan, gray, green, maroon. **Please call for samples.**

### 1949-52 CARS

**1949-52 COUPE** - ORDER # 4707-24

**1949-52 2-DR. SEDAN** - ORDER # 4707-20

**1949-52 4-DR. SEDAN** - ORDER # 4707-21

**1949-52 CONVERTIBLE** - ORDER # 4707-22

**1949-52 HARDTOP** - ORDER # 4707-23

### 1953-54 CARS

**1953-54 2-DR. SEDAN** - ORDER # 707-20

**1953-54 4-DR. SEDAN** - ORDER # 707-21

**1953-54 CONVERTIBLE** - ORDER # 707-22

**1953-54 HARDTOP** - ORDER # 707-23

*Cut Pile* **\$249<sup>00</sup>** Set

*Samples Available*



## ORIGINAL STYLE REPLACEMENT CARPET

Carpet is sewn just like original carpet with sewn hump binding and vinyl heel pad. Open on sides for easy installation up to sill plates. Pad is also cut for easy installation. Carpet and pad should be glued down for a nicer look. Available in red, black, brown, maroon. **Please call for samples.**

### 1949-52 CARS

**1949-52 COUPE** - ORDER # 4707-26

**1949-52 2-DR. SEDAN** - ORDER # 4707-27

**1949-52 4-DR. SEDAN** - ORDER # 4707-28

**1949-52 CONVERTIBLE** - ORDER # 4707-29

**1949-52 HARDTOP** - ORDER # 4707-30

### 1953-54 CARS

**1953-54 2-DR. SEDAN** - ORDER # 707-25

**1953-54 4-DR. SEDAN** - ORDER # 707-26

**1953-54 CONVERTIBLE** - ORDER # 707-27

**1953-54 HARDTOP** - ORDER # 707-28

*Loop* **\$249<sup>00</sup>** Set

*Samples Available*

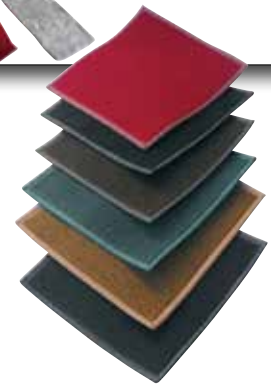

# CARPET

## CUSTOM CARPET SET

This carpet set is sewn like the original carpet with sewn hump binding and vinyl heel pad. Open on sides for easy installation under sill plates. Pad also cut for easy simple installation. Carpet is bound where needed. Available in red, black, brown, tan, gray, green, maroon. Carpet and pad should be glued down for a nicer look.

- 1949-52 COUPE** - ORDER # 4707-5
- 1949-52 2-DR. SEDAN** - ORDER # 4707-2
- 1949-52 4-DR. SEDAN** - ORDER # 4707-4
- 1949-52 CONVERTIBLE** - ORDER # 4707-6
- 1949-52 HARDTOP** - ORDER # 4707-7

- 1953-54 2-DR. SEDAN** - ORDER # 707-2
- 1953-54 4-DR. SEDAN** - ORDER # 707-4
- 1953-54 CONVERTIBLE** - ORDER # 707-C
- 1953-54 HARDTOP** - ORDER # 707-H

*Samples Available*

*Cut Pile*

**\$219<sup>00</sup>** Set



## CUSTOM CARPET SET

This carpet set is sewn like the original carpet with sewn hump binding and vinyl heel pad. Open on sides for easy installation under sill plates. Pad also cut for easy simple installation. Carpet is bound where needed. Available in red, black, brown, blue, maroon. Carpet and pad should be glued down for a nicer look. Please call for color samples.

- 1949-52 2-DR. SEDAN** - ORDER # 4706-2
- 1949-52 4-DR. SEDAN** - ORDER # 4706-4
- 1949-52 CONVERTIBLE** - ORDER # 4706-6
- 1949-52 HARDTOP** - ORDER # 4706-7
- 1949-52 COUPE** - ORDER # 4706-5

- 1953-54 2-DR. SEDAN** - ORDER # 706-2
- 1953-54 4-DR. SEDAN** - ORDER # 706-4
- 1953-54 CONVERTIBLE** - ORDER # 706-C
- 1953-54 HARDTOP** - ORDER # 706-H

*Call for Color Samples*

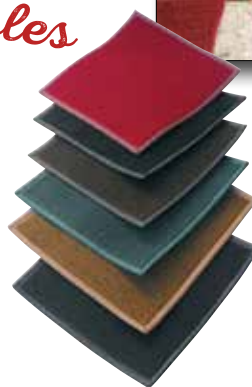

*Loop*  
**\$219<sup>00</sup>** Set





# DOOR SILL PLATES

## 1949-52 REPLACEMENT DOOR SILL PLATES

"Replacement" sill plates are now made of heavy gauge aluminum and are available in two finishes. The polished model has a bright shiny chrome look finish and the brushed have a more subdued satiny finish. Also includes tags. They are not stamped like original. *Polished sill plates have a "P" behind the order number.*

### 1949-52

**2-DR. SEDAN** ..... ORDER #4706

**\$80<sup>00</sup>**

ORDER #4706-P

**\$105<sup>00</sup>**

**4-DR. SEDAN** ..... ORDER #4708

**\$155<sup>00</sup>**

ORDER #4708-P

**\$200<sup>00</sup>**

**SEDAN DELIVERY** ..... ORDER #4709

**\$80<sup>00</sup>**

ORDER #4709-P

**\$105<sup>00</sup>**

**HARDTOP/CONV.** ..... ORDER #4710

**\$80<sup>00</sup>**

ORDER #4710-P

**\$105<sup>00</sup>**

### 1953-54

**2-DR. SEDAN OR  
2-DR. HARDTOP** ..... ORDER #703

**\$80<sup>00</sup>** pr.

ORDER #703-P

**\$105<sup>00</sup>** pr.

**CONVERTIBLE** ..... ORDER #780R

**\$80<sup>00</sup>** pr.

ORDER #780R-P

**\$105<sup>00</sup>** pr.

**4-DR. SEDAN** ..... ORDER #704-4

**\$155<sup>00</sup>** set

ORDER #704-4P

**\$200<sup>00</sup>** set

**SEDAN DELIVERY** ..... ORDER #704D

**\$80<sup>00</sup>** pr.

ORDER #704D-P

**\$105<sup>00</sup>** pr.



### SILL PLATE TAG

Fits 1949-54 cars.



ORDER #791  
**\$5** pr.

### RETURN POLICY

Any part that is not satisfactory may be returned within **30 days** for a **full refund**. Shipping charges will not be refunded.

**ALL RETURNS must be accompanied by a copy of the invoice or item will be sent back to you. All parts must be returned in original package in resalable condition.**

If an item is defective or we made an error on your order we will reimburse your return shipping at regular ground rates. (If you order a part shipped by air, you will not be refunded the **extra** shipping cost.) If you return a part because you decided not to use it, you're responsible for the shipping charges.

**NO RETURNS AFTER 30 DAYS.**  
**NO RETURNS WITHOUT A COPY OF THE INVOICE.**  
 Any returns after 30 days will have serious penalties and must be accompanied by a receipt.  
 CALL FIRST! 651-778-9522.

# DOOR SILL PLATES



780



780-4



4703

## ORIGINAL REPLACEMENT DOOR SILL PLATES

Deep stamped with original design  
and "Body By Fisher" tag.  
Excellent quality!



4705



4704

- |  |              |                               |
|--|--------------|-------------------------------|
| <b>1949-52 2-DR. SEDAN</b> .....                       | ORDER #4703  | <b>\$180<sup>00</sup></b>     |
| <b>1949-52 HARDTOP/<br/>CONVERTIBLE</b> .....          | ORDER #4704  | <b>\$180<sup>00</sup></b>     |
| <b>1949-52 4-DR. SEDAN</b> .....                       | ORDER #4705  | <b>\$300<sup>00</sup></b>     |
| <b>1953-54 2-DR. SEDAN OR<br/>2-DR. HARDTOP</b> .....  | ORDER #780   | <b>\$185<sup>00</sup></b> pr. |
| <b>1953-54 ORIGINAL<br/>REPLACEMENT 4-DR. SEDAN</b> .. | ORDER #780-4 | <b>\$300<sup>00</sup></b> set |

*Phone Us*  
651-778-9522

*Fax Us*  
1-800-785-5354

*Tech help*

available from  
3:30-5:00 p.m. CST  
**MOST DAYS**

*Mail Us*  
National Chevy Association  
947 Arcade  
St. Paul, MN 55106

*Website*  
[www.nationalchevyassoc.com](http://www.nationalchevyassoc.com)



*Alan B  
United Kingdom*



# KICK PANELS



*Bodfish, California*

## 1949-52 KICK AND DECK PANEL SOUND DEADENING KIT

Uses thin padding under your deck panel and behind your kick panels for a quieter ride.

**STYLELINE  
2 & 4 DR. SEDAN**

ORDER #6485

**COUPE**

ORDER #6485-1

**HARDTOP**

ORDER #6485-2

**FLEETLINE  
2 & 4 DOOR SEDAN**

ORDER #6486



**\$20<sup>00</sup>** set

**INSULATION FOR  
KICKS ONLY**

ORDER #6487

**\$14<sup>00</sup>** pr.

## 1953-54 KICK AND DECK PANEL SOUND DEADENING KIT

Uses thin padding under your deck panel and behind your kick panels for a quieter ride.

**COUPE**

ORDER #798

**2 & 4 DR. SEDAN**

ORDER #798-1

**HARDTOP**

ORDER #798-2



**\$20<sup>00</sup>**

**KICKS ONLY**

ORDER #798-3

**\$14<sup>00</sup>**

# PACKAGE SHELF/KICK PANELS

## 1949-52

### STYLELINE SEDAN

BLACK	ORDER #4717-1
RED	ORDER #4717-2
DK. GREEN	ORDER #4717-3
DK. BLUE	ORDER #4717-4
BROWN	ORDER #4717-5
GRAY	ORDER #4717-6

### FLEETLINE SEDAN

BLACK	ORDER #4717-7
RED	ORDER #4717-8
DK. GREEN	ORDER #4717-9
DK. BLUE	ORDER #4717-10
BROWN	ORDER #4717-11
GRAY	ORDER #4717-12

### COUPE

BLACK	ORDER #4717-13
RED	ORDER #4717-14
DK. GREEN	ORDER #4717-15
DK. BLUE	ORDER #4717-16
BROWN	ORDER #4717-17
GRAY	ORDER #4717-18

### BEL AIR HARDTOP

BLACK	ORDER #4717-19
RED	ORDER #4717-20
DK. GREEN	ORDER #4717-21
DK. BLUE	ORDER #4717-22
BROWN	ORDER #4717-23
GRAY	ORDER #4717-24

## REAR PACKAGE SHELF (DECK PANEL)



New cardboard tray sewn with correct color trim attached. (Headliner material and/or vinyl, depending on model.)

Recommended to replace when replacing headliner.

**\$35<sup>00</sup>** ea.

## 1953-54

### SEDAN

ORDER #717-1	— BLACK
ORDER #717-2	— RED
ORDER #717-3	— DK. GREEN
ORDER #717-4	— DK. BLUE
ORDER #717-5	— BROWN
ORDER #717-13	— GRAY
ORDER #717-15	— LT. GREEN (54)
ORDER #717-CP	(Coupe)

### HARDTOP

ORDER #717-7	— BLACK
ORDER #717-8	— RED
ORDER #717-9	— DK. GREEN
ORDER #717-10	— DK. BLUE
ORDER #717-11	— BROWN
ORDER #717-14	— GRAY
ORDER #717-16	— LT. GREEN (54)

**\$35<sup>00</sup>** ea.

## 1949-52 KICK PANELS

Kick panels available in correct colors with center hole for easy installation all models.

BLACK	ORDER #4716-1
RED	ORDER #4716-2
DK. GREEN	ORDER #4716-3
DK. BLUE	ORDER #4716-4
BROWN	ORDER #4716-5
GRAY	ORDER #4716-6

**\$20<sup>00</sup>** pr.

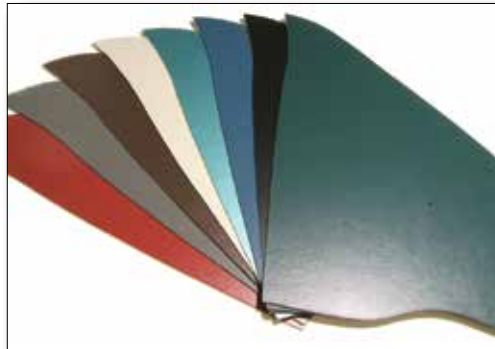

## 1953-54 KICK PANELS

Complete with center hole for easy installation.

**\$20<sup>00</sup>** pr.

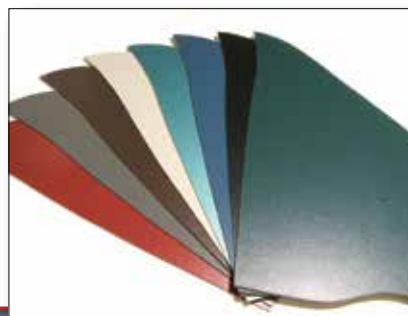

ORDER #716-1	— BLACK
ORDER #716-2	— RED
ORDER #716-3	— GREEN
ORDER #716-4	— DK. BLUE
ORDER #716-5	— BROWN
ORDER #716-7	— GRAY
ORDER #716-8	— IVORY
ORDER #716-9	— LT. GREEN (54)



### SEAT BELTS

While not original equipment in your old Chevy, today's style of driving requires some additional safety equipment. **These lap belts will keep your passengers and yourself safer.** They are easy to install, but are available in black only.



**FRONT SEAT  
ORDER #327F  
\$74<sup>00</sup> pr.**

**REAR SEAT  
ORDER #327R  
\$74<sup>00</sup> pr.**

### 1951-54 ARM RESTS

Great new reproduction. Available in beige and black. Not correct for 1949-50, but will work. Screws included.

**BEIGE ORDER #579**

**BLACK ORDER #579-1**

**\$99<sup>00</sup> pr.**



### FRONT SEAT BRACES

Installs under seat (under floor).  
For 1949-52 and 1953-54 cars.

**1949-52**

**DRIVER SIDE ORDER #7109-49L**

**PASS. SIDE ORDER #7109-49R**

**\$65 ea.**

**1953-54**

**DRIVER SIDE ORDER #7109-53L**

**PASS. SIDE ORDER #7109-53R**

**\$89 ea.**



*(1953-54  
Braces pictured)*

### 1951-54 REAR SEAT ARMRESTS WITH ASHTRAY

Excellent reproduction that has chrome plated ashtray and chrome band. Ready to install and mounting screws are included.

Black only. **Not for hardtop or convertible.**

**ORDER #579-2**

**\$160<sup>00</sup> pr.**





*Earl & Ginny  
Virginia*



*Gary  
Texas*



*Ray  
, New Jersey*



*Junkyard  
Minnesota*



# CENTURY CUSTOM INTERIOR

## Smooth Cut Velour

A complete custom interior kit for your car using Bristol Fabric matching vinyl fabric. Easy to install and reasonably priced for a great looking interior.

### Includes:

- Front and rear seat covers in Bristol cloth and vinyl. Also includes seat side shell covers in vinyl.
- Pre-sewn brushed cotton headliner.
- Loop or cut pile matching carpet pre-sewn with bound edges and heel pad. Carpet pad included.
- Replacement cardboard kick panels and rear package shelf.
- Cloth windlace pre-sewn to factory specs for easy installation. "Wire on" included for 1949 to 1952 models.
- Cloth covered sunvisors. You must send us your cores to recover - minus mounting hardware.
- Preassembled door panels include new waterproof cardboard covered with padded fabric and new metal edge support strips. Ready to install using your stainless trim pieces. Also includes armrest covers.

Available in tan, brown, blue and burgundy.

**NOTE: Smooth cut velour fabric can be used instead of Imperial fabric. CALL FOR COLOR SAMPLES.**





**PLEATED  
DOOR  
PANELS**

Pleated door panels are available for an additional \$150.00 for the 4 panels. A great choice if you don't have good or any stainless.

Complete!  
Affordable!

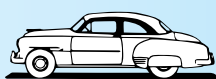

**2-DR. STYLELINE  
CENTURY**

ORDER #6550 **\$1995**

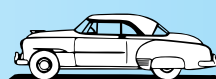

**1949-52  
BUSINESS COUPE  
CENTURY**

ORDER #6553 **\$1795**

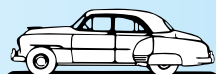

**4-DR. STYLELINE  
CENTURY**

ORDER #6551 **\$2195**

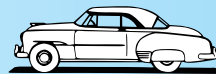

**BEL AIR HARDTOP  
CENTURY**

ORDER #6554 **\$1995**



**COUPE CENTURY**

ORDER #6552 **\$1995**

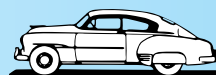

**2-DOOR FLEETLINE  
VINTAGE**

ORDER #6555 **\$1995**

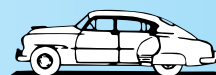

**4-DOOR FLEETLINE  
VINTAGE**

ORDER #6556 **\$2195**

# CENTURY CUSTOM INTERIOR



*Fabric  
& Vinyl*



**1953-54**

*Specify 150, 210  
or BelAir Series*

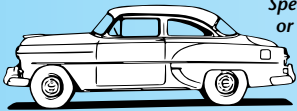

**2-DR. SEDAN**

ORDER #2545 **\$1995**

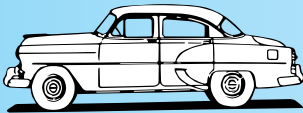

**4-DR. SEDAN**

ORDER #2546 **\$2195**

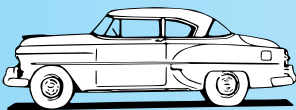

**2-DR. HARDTOP**

ORDER #2547 **\$1995**

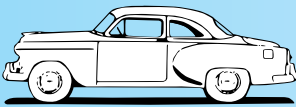

**1953 CLUB COUPE**

ORDER #2548 **\$1995**

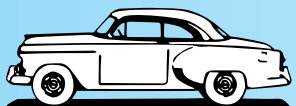

*No back  
seat*

**1953 BUSINESS COUPE**

ORDER #2549 **\$1795**



*Color Samples  
Available*

**CONTACT US FOR SAMPLES IN  
YOUR CHOICE OF COLOR.**

*Everything  
in  
One Kit!*





# VINTAGE II CUSTOM INTERIOR

## All fabric interior

The new Vintage II interior has changed to Bristol, a soft patterned fabric. It also now has a larger variety of colors to offer. The kit is easy to install and reasonably priced for a great looking interior.

### Includes:

- Front and rear seat covers in Bristol fabric. Also includes seat side shell covers.
- Pre-sewn brushed cotton headliner.
- Loop or cut pile matching carpet pre-sewn with bound edges and heel pad. Carpet pad included.
- Replacement cardboard kick panels and rear package shelf.
- Cloth windlace pre-sewn to factory specs for easy installation. "Wire on" included for 1949-52 models.
- Cloth covered sunvisors. You must send us your cores to recover - minus mounting hardware.
- Preassembled door panels include new waterproof cardboard covered with padded fabric and new metal edge support strips. Ready to install using your stainless trim pieces. Also includes armrest covers.

*New*

### PLEATED DOOR PANELS

Set of 4 for an additional \$150.00. Great if you don't have stainless for your doors.

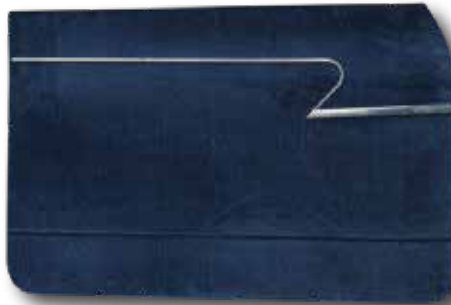

*Complete affordable interior!*

Interiors are available in light charcoal, toast, walnut, ocean (blue) and burgundy.

## 1949-52

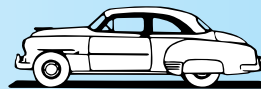

### 2-DR. STYLELINE

ORDER #6530

**\$2095**

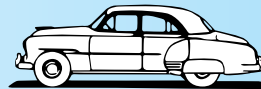

### 4-DR. STYLELINE

ORDER #6531

**\$2295**

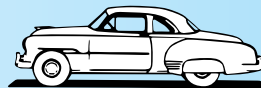

### COUPE

ORDER #6534

**\$2095**

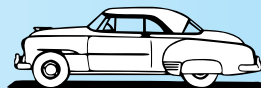

### BUSINESS COUPE

ORDER #6535

**\$1895**

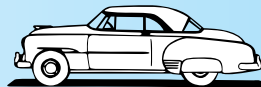

### BEL AIR HARDTOP

ORDER #6523-V

**\$2095**



### 2-DOOR FLEETLINE

ORDER #6532

**\$2095**

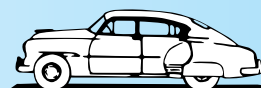

### 4-DOOR FLEETLINE

ORDER #6533

**\$2295**

# VINTAGE II CUSTOM INTERIOR

*Smooth cut velour fabric*



**1953-54**

Specify 150, 210  
or BelAir Series

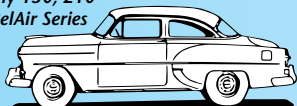

**2-DR. SEDAN**

ORDER #2530

**\$2095**

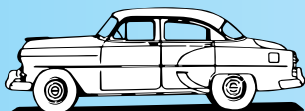

**4-DR. SEDAN**

ORDER #2531

**\$2295**

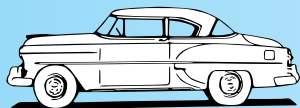

**2-DR. HARDTOP**

ORDER #2530-H

**\$2095**

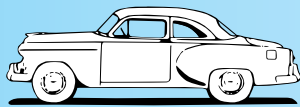

**1953 CLUB COUPE**

ORDER #2532

**\$2095**

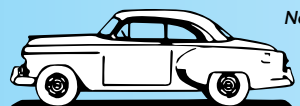

*No back  
seat*

**1953 BUSINESS COUPE**

ORDER #2533

**\$1895**



*Color Samples  
Available*

*CONTACT US FOR SAMPLES IN  
YOUR CHOICE OF COLOR.*





# DELUXE CUSTOM INTERIOR

**Includes:**

- Vinyl seat and seat side shell covers. Front and rear included.
- Pre-sewn brushed cotton headliner.
- Cloth-covered sunvisors. *You must send your cores to us to recover - minus hardware.*
- Cloth windlace pre-sewn to factory specs for easy installation.
- Replacement, matching kick panels and rear package tray.
- Preassembled vinyl covered door panels include new waterproof cardboard with padded fabric and new metal edge strips. Ready to install using your stainless and includes armrest covers.
- Matching loop or cut pile carpet completes your interior. Carpet is pre-sewn with bound edges and heel pad. Pre-cut carpet pad also included.

Sturdy vinyl interior available in turquoise, dark green, red, black, dark blue, white, beige, brown. White carpet not available

## 1949-52



**2-DR. STYLELINE**

ORDER #6663 **\$1995**



**4-DR. STYLELINE**

ORDER #6664 **\$2195**



**COUPE**

ORDER #6665 **\$1995**



**BUSINESS COUPE**

ORDER #6666 **\$1795**



**BEL AIR HARDTOP**

ORDER #6667 **\$1995**



**2-DOOR FLEETLINE**

ORDER #6668 **\$1995**



**4-DOOR FLEETLINE**

ORDER #6669 **\$2195**

**CONVERTIBLE**

ORDER #6649 **\$1795**

### New PLEATED DOOR PANELS



Great to use if you don't have any door stainless.

For only \$150.00 you can use the set of 4 panels and solve your problem.



NOTE: Only seat covers and door panels are white. Windlace, headliner, carpet and visors will be your choice of another color.

Complete affordable interior!

# DELUXE CUSTOM INTERIOR

*All vinyl seats*



**1953-54**

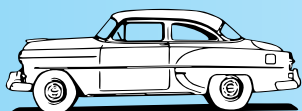

**2-DR. SEDAN**

ORDER #6670 **\$1995**

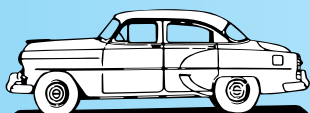

**4-DR. SEDAN**

ORDER #6671 **\$2195**

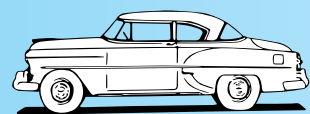

**2-DR HARDTOP**

ORDER #6672 **\$1995**

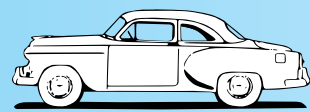

**1953 CLUB COUPE**

ORDER #6674 **\$1995**

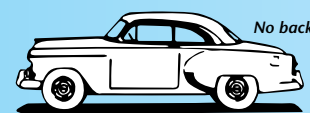

*No back seat*

**1953 BUSINESS COUPE**

ORDER #6675 **\$1795**

**CONVERTIBLE**

ORDER #6673 **\$1795**



*Color Samples Available*

*CONTACT US FOR SAMPLES IN YOUR CHOICE OF COLOR.*



# CLASSIC CUSTOM INTERIOR

## New PLEATED DOOR PANELS

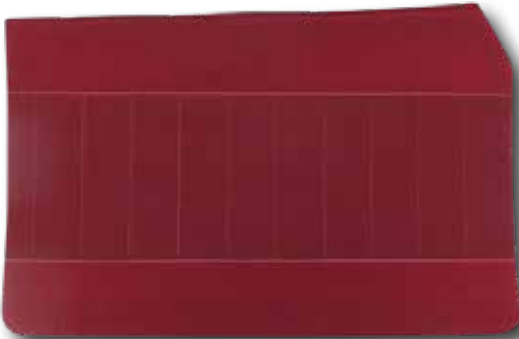

No stainless?  
No worry.  
These pleated  
panels don't  
require any.

Set of 4  
panels for  
only \$150.00  
additional  
charge.

## Nice fabric

A complete custom interior kit for your car using textured and smooth velour fabric. Easy to install and reasonably priced for a great looking interior.

### Includes:

- Front and rear seat covers in textured/smooth velour. Also includes seat side shell covers.
- Pre-sewn brushed cotton headliner
- Loop or cut pile matching carpet pre-sewn with bound edges and heel pad. Carpet pad included.
- Replacement cardboard kick panels and rear package shelf.
- Cloth windlace pre-sewn to factory specs for easy installation.
- **Cloth covered sunvisors. You must send us your cores to recover - minus mounting hardware**
- Preamsembled door panels include new waterproof cardboard covered with padded fabric and new metal edge support strips. Ready to install using your stainless trim pieces. Also includes armrest covers and wire-on windlace for 1949-52 models.

Available in gray, blue, green, tan, black and red.

## 1949-52

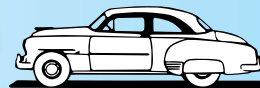

**2-DR. STYLELINE**  
ORDER #6521-S **\$2295**

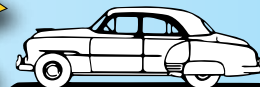

**4-DR. STYLELINE**  
ORDER #6522-S **\$2495**

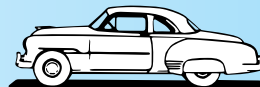

**COUPE**  
ORDER #6524 **\$2295**

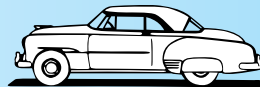

**BUSINESS COUPE**  
ORDER #6525 **\$2095**

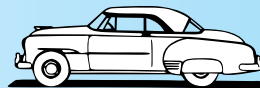

**BEL AIR HARDTOP**  
ORDER #6523 **\$2295**

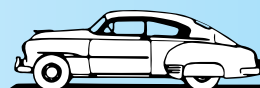

**2-DOOR FLEETLINE**  
ORDER #6521-F **\$2295**

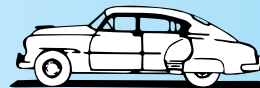

**4-DOOR FLEETLINE**  
ORDER #6522-F **\$2495**

**Upgrade  
to Pleated  
Seats  
And Door  
Panels  
Only  
\$200**

*For the Price,  
this  
Complete Kit  
Cannot Be  
Beat!*

# CLASSIC CUSTOM INTERIOR

*Cool seat in hot weather*



**1953-54**

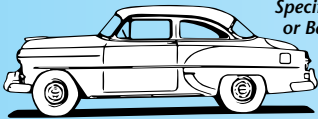

*Specify 150, 210  
or BelAir Series*

**2-DR. SEDAN**

ORDER #2521 **\$2295**

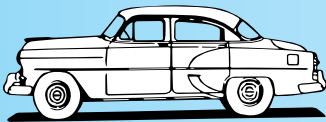

**4-DR. SEDAN**

ORDER #2522 **\$2495**

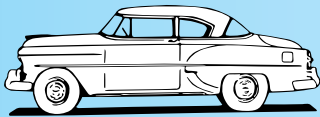

**2-DR. HARDTOP**

ORDER #2523 **\$2295**

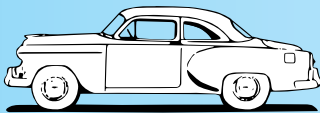

**1953 CLUB COUPE**

ORDER #2524 **\$2295**

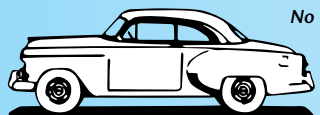

*No back seat*

**1953 BUSINESS COUPE**

ORDER #2525 **\$2095**



*Color Samples  
Available*

CONTACT US FOR SAMPLES IN  
YOUR CHOICE OF COLOR.



# CLASSIC CUSTOM II INTERIOR

## New PLEATED DOOR PANELS

Now you can add pleated door panels to your interior for an attractive yet economical interior.

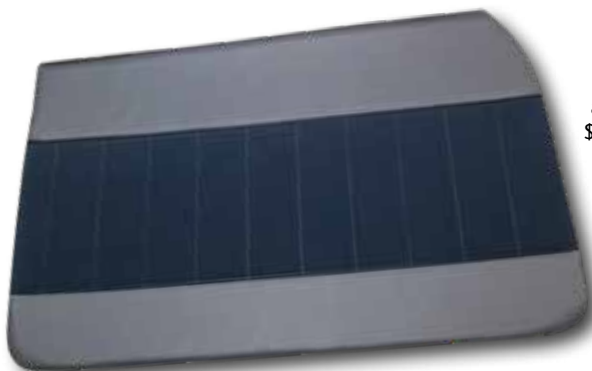

Costs only an additional \$150.00 for the set of 4 panels.

### Includes:

- Front and rear seat covers in imperial cloth and vinyl pleated like classic custom. Also includes seat side shell covers in vinyl.
- Pre-sewn brushed cotton headliner.
- Loop or cut pile matching carpet pre-sewn with bound edges and heel pad. Carpet pad included.
- Replacement cardboard kick panels and rear package shelf.
- Cloth windlace pre-sewn to factory specs for easy installation. "Wire on" included for 1949-52 cars.
- Cloth covered sunvisors. *You must send us your cores to recover - minus mounting hardware.*
- Preassembled door panels include new waterproof cardboard covered with cloth and vinyl padded fabric and new metal edge support strips. Ready to install using your stainless trim pieces. Also includes armrest covers.

All items are also sold separately - call for prices.

## 1949-52

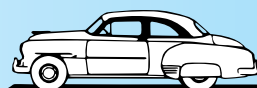

**2-DR. STYLELINE**  
ORDER #6521-S2 **\$2295**

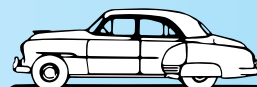

**4-DR. STYLELINE**  
ORDER #6522-S2 **\$2495**

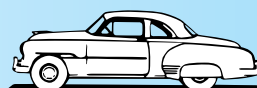

**COUPE**  
ORDER #6524-C2 **\$2295**

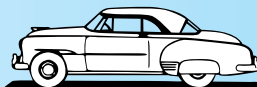

**BUSINESS COUPE**  
ORDER #6525-2BC **\$2095**

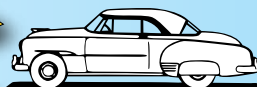

**BEL AIR HARDTOP**  
ORDER #6523-H **\$2295**

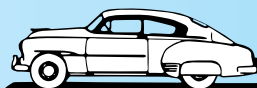

**2-DOOR FLEETLINE**  
ORDER #6521-F2 **\$2295**

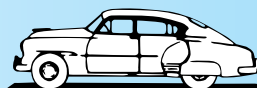

**4-DOOR FLEETLINE**  
ORDER #6522-F2 **\$2495**

Upgrade to Pleated Seats And Door Panels only **\$200**

Complete affordable interior!

# CLASSIC CUSTOM II INTERIOR



**1953-54**

*Specify 150, 210  
or BelAir Series*

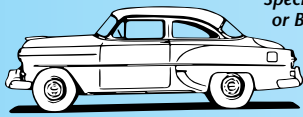

**2-DR. SEDAN**

ORDER #2521A

**\$2295**

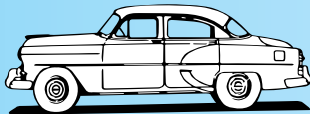

**4-DR. SEDAN**

ORDER #2522A

**\$2495**

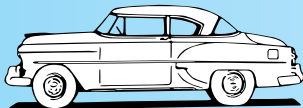

**2-DR. HARDTOP**

ORDER #2523A

**\$2295**

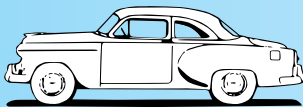

**1953 CLUB COUPE**

ORDER #2524A

**\$2295**

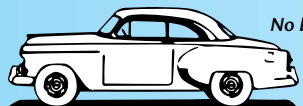

*No back seat*

**1953 BUSINESS COUPE**

ORDER #2525A

**\$2095**



*Color Samples  
Available*

**CONTACT US FOR SAMPLES IN  
YOUR CHOICE OF COLOR.**

*Everything  
in One Kit!*



**Interiors are  
available in  
blue, gray,  
red, tan, black  
and green.**

**Sample kits  
available.**



# CUSTOM ROYAL INTERIOR



*Color Samples Available*

CONTACT US FOR SAMPLES IN YOUR CHOICE OF COLOR.

## Includes:

- Front and rear seat covers in soft leatherette. Also include seat side shell covers.
- Pre-sewn brushed cotton headliner.
- Loop or cut pile matching carpet pre-sewn like original with leatherette-bound edges and heel pad. Carpet pad included.
- Replacement leatherette covered kick panels.
- Replacement rear package shelf with leatherette-bound edges.
- Pre-sewn leatherette windlace for easy installation - wire-on included on 1949-52 models.
- Cloth-covered sunvisors. You must send us your cores to recover - minus mounting hardware.
- Pre-assembled leatherette-covered door panels include new waterproof cardboard and new metal edge support strips. Ready to install using your stainless trim pieces. Armrest covers also included.

Available in black, dark green, gray, red, taupe and dark blue.



**NOTE: Pleated door panels also available for an additional charge of \$150.00.**

**Door stainless CANNOT be used on pleated door panels.**

## 1949-52

### 2-DR. STYLELINE

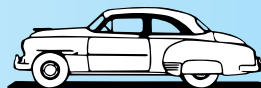

ORDER #6650 **\$2395**

### 4-DR. STYLELINE

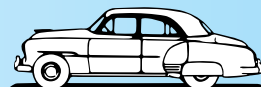

ORDER #6651 **\$2595**

### COUPE

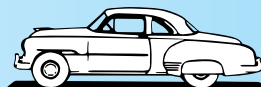

ORDER #6652 **\$2395**

### BUSINESS COUPE

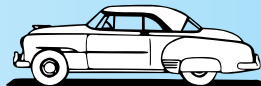

ORDER #6653 **\$2195**

### BEL AIR HARDTOP

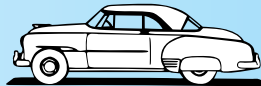

ORDER #6654 **\$2395**

### 2-DOOR FLEETLINE

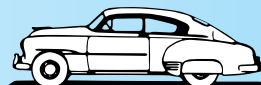

ORDER #6655 **\$2395**

### 4-DOOR FLEETLINE

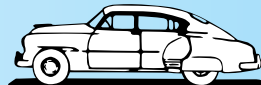

ORDER #6657 **\$2595**

### CONVERTIBLE

ORDER #6526 **\$2195**

# CUSTOM ROYAL INTERIOR

*Custom  
Royal  
Leatherette  
"Looks like  
leather -  
Feels like  
leather"*

**1953-54**

*Specify year  
and model of  
1953-54 Chevy*

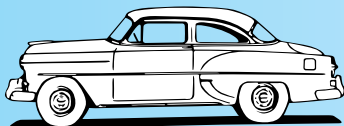

**2-DR. SEDAN**

ORDER  
#6658

**\$2395**

*Specify Model & Year*

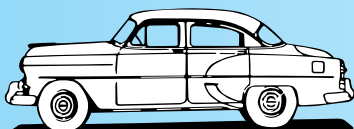

**4-DR. SEDAN**

ORDER  
#6659

**\$2595**

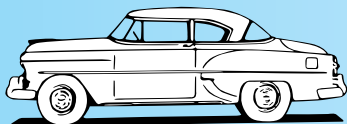

**2-DR. HARDTOP**

ORDER  
#6660

**\$2395**

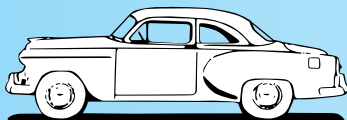

**1953 CLUB COUPE**

ORDER  
#6661

**\$2395**

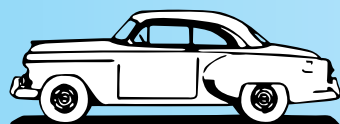

**1953 BUSINESS COUPE**

ORDER  
#6662

**\$2195**

**CONVERTIBLE**

ORDER  
#6526

**\$2195**



*Complete!  
Affordable!*



*Color Samples  
Available*

**CONTACT US FOR SAMPLES IN  
YOUR CHOICE OF COLOR.**

**NOTE: Pleated door panels also available  
for an additional charge of \$150.00.**

**Door stainless CANNOT be used on pleated door panels.**



# CUSTOM ROYAL II



Available in green, burgundy, blue, taupe, black and gray.

*Before You Order*

Call for Free Color Samples

*This interior is sewn in soft leatherette with velour fabric inserts in seats and door panels.*

**Includes:**

- Front and rear seat covers. Also include seat side shell covers.
- Pre-sewn brushed cotton headliner.
- Loop or cut pile matching carpet pre-sewn like original with leatherette-bound edges and heel pad. Carpet pad included.
- Replacement leatherette covered kick panels.
- Replacement rear package shelf with leatherette-bound edges.
- Pre-sewn leatherette windlace for easy installation - wire-on included on 1949-52 models.
- Cloth-covered sunvisors. You must send us your cores to recover - minus mounting hardware.
- Pre-assembled pleated leatherette/fabric insert covered door panels include new waterproof cardboard and metal edge support strips. DOOR STAINLESS CANNOT BE USED ON PLEATED PANELS. Armrest covers also included.



**1949-52** SPECIFY YEAR AND MODEL

**2-DR. STYLELINE**

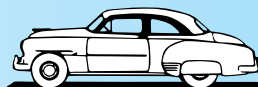

ORDER #6650-II **\$2395**

**4-DR. STYLELINE**

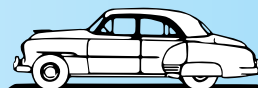

ORDER #6651-II **\$2595**

**COUPE**

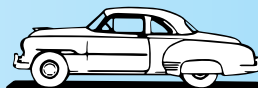

ORDER #6652-II **\$2395**

**BUSINESS COUPE**

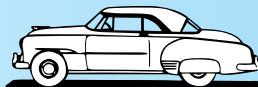

ORDER #6653-II **\$2195**

**BEL AIR HARDTOP**

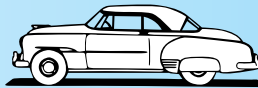

ORDER #6654-II **\$2395**

**2-DOOR FLEETLINE**

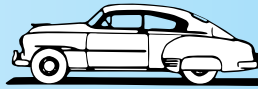

ORDER #6655-II **\$2395**

**4-DOOR FLEETLINE**

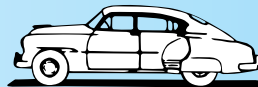

ORDER #6657-II **\$2595**

**CONVERTIBLE**

ORDER #6526-II **\$2195**

# CUSTOM ROYAL II

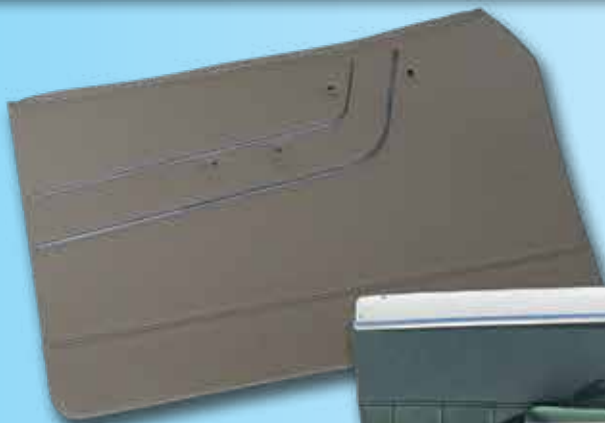

## 1953-54

Specify year and model of 1953-54 Chevy

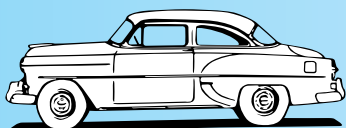

### 2-DR. SEDAN

ORDER  
#6658-II

**\$2395**

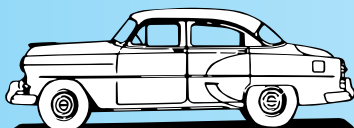

### 4-DR. SEDAN

ORDER  
#6659-II

**\$2595**

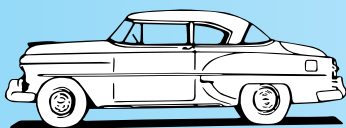

### 2-DR. HARDTOP

ORDER  
#6660-II

**\$2395**

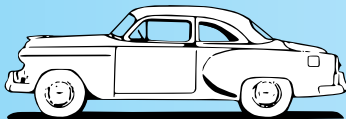

### 1953 CLUB COUPE

ORDER  
#6661-II

**\$2395**

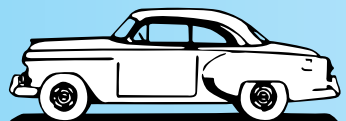

### 1953 BUSINESS COUPE

ORDER  
#6662-II

**\$2195**

### CONVERTIBLE

ORDER  
#2525-II

**\$2195**

Color Samples  
Available

CONTACT US FOR SAMPLES IN  
YOUR CHOICE OF COLOR.

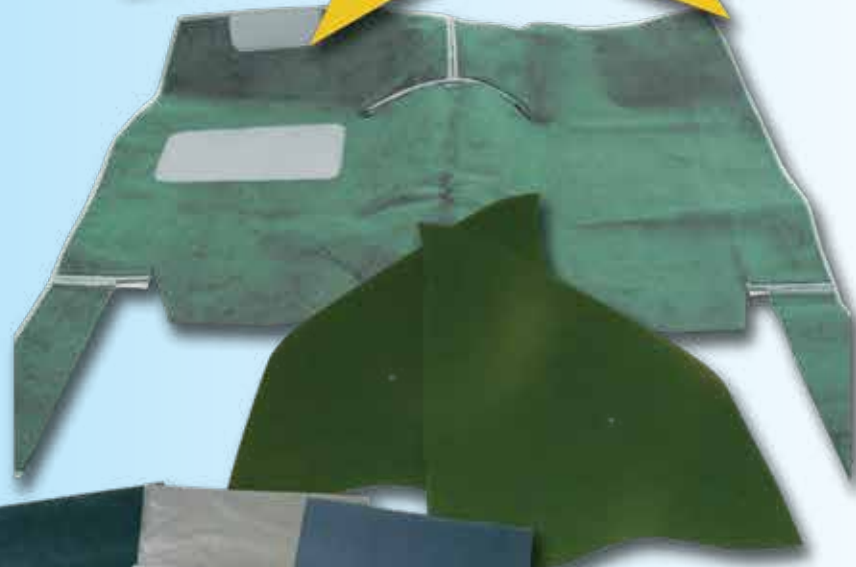



# SEAT CUSHION PADDING REPLACEMENT KIT



**OLD SEAT**

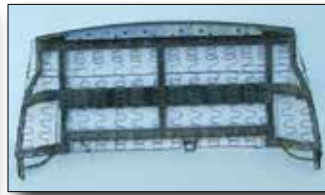

**CLEANED SEAT**



**NEW KIT**

Smelly old seats?  
Before you recover them,  
replace old padding with  
some fresh new stuff.

**Seat Cushion Kit**

**Seat Back Kit**

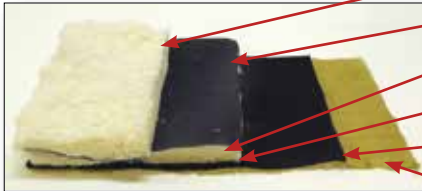

- 1 Layer cotton
- 1 Layer Liner
- 1 Layer Compressed Cotton
- 1 Layer Liner
- 1 Layer Poly Felt
- 1 Layer Burlap

- 1 Layer Foam
- 1 Layer Liner
- 1 Layer Compressed Cotton
- 1 Layer Liner
- 1 Layer Carpet Pad
- 2 Layer Burlap

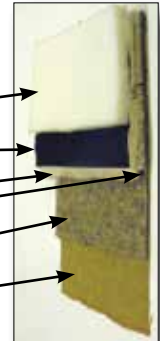

## 1949-52 MODELS

### 2 DOOR SEDAN

- FRONT SEAT BACK ..... Order #6576A **\$75** pr.
- FRONT SEAT CUSHION ..... Order #6576B **\$75** ea.
- REAR SEAT BACK ..... Order #6576C **\$75** ea.
- REAR CUSHION ..... Order #6576D **\$75** ea.

### 2 DOOR COUPE

- FRONT SEAT BACK ..... Order #6577A **\$75** pr.
- FRONT SEAT CUSHION ..... Order #6577B **\$75** ea.
- REAR SEAT BACK ..... Order #6577C **\$75** ea.
- REAR CUSHION ..... Order #6577D **\$75** ea.

### 2 DOOR HARDTOP

- FRONT SEAT BACK ..... Order #6578A **\$75** pr.
- FRONT SEAT CUSHION ..... Order #6578B **\$75** ea.
- REAR SEAT BACK ..... Order #6578C **\$75** ea.
- REAR CUSHION ..... Order #6578D **\$75** ea.

### 2 DOOR CONVERTIBLE

- FRONT SEAT BACK ..... Order #6579A **\$75** pr.
- FRONT SEAT CUSHION ..... Order #6579B **\$75** ea.
- REAR SEAT BACK ..... Order #6579C **\$75** ea.
- REAR CUSHION ..... Order #6579D **\$75** ea.

### 4 DOOR SEDAN

- FRONT SEAT BACK ..... Order #6580A **\$75** ea.
- FRONT SEAT CUSHION ..... Order #6580B **\$75** ea.
- REAR SEAT BACK ..... Order #6580C **\$75** ea.
- REAR CUSHION ..... Order #6580D **\$75** ea.

## 1953-54 MODELS

### 2 DOOR SEDAN

- FRONT SEAT BACK ..... Order #6571A **\$75** pr.
- FRONT SEAT CUSHION ..... Order #6571B **\$75** ea.
- REAR SEAT BACK ..... Order #6571C **\$75** ea.
- REAR CUSHION ..... Order #6571D **\$75** ea.

### 2 DOOR COUPE

- FRONT SEAT BACK ..... Order #6572A **\$75** pr.
- FRONT SEAT CUSHION ..... Order #6572B **\$75** ea.
- REAR SEAT BACK ..... Order #6572C **\$75** ea.
- REAR CUSHION ..... Order #6572D **\$75** ea.

### 2 DOOR HARDTOP

- FRONT SEAT BACK ..... Order #6573A **\$75** pr.
- FRONT SEAT CUSHION ..... Order #6573B **\$75** ea.
- REAR SEAT BACK ..... Order #6573C **\$75** ea.
- REAR CUSHION ..... Order #6573D **\$75** ea.

### 2 DOOR CONVERTIBLE

- FRONT SEAT BACK ..... Order #6574A **\$75** pr.
- FRONT SEAT CUSHION ..... Order #6574B **\$75** ea.
- REAR SEAT BACK ..... Order #6574C **\$75** ea.
- REAR CUSHION ..... Order #6574D **\$75** ea.

### 4 DOOR SEDAN

- FRONT SEAT BACK ..... Order #6575A **\$75** ea.
- FRONT SEAT CUSHION ..... Order #6575B **\$75** ea.
- REAR SEAT BACK ..... Order #6575C **\$75** ea.
- REAR CUSHION ..... Order #6575D **\$75** ea.

# THE ADVENTURES OF BARNEY

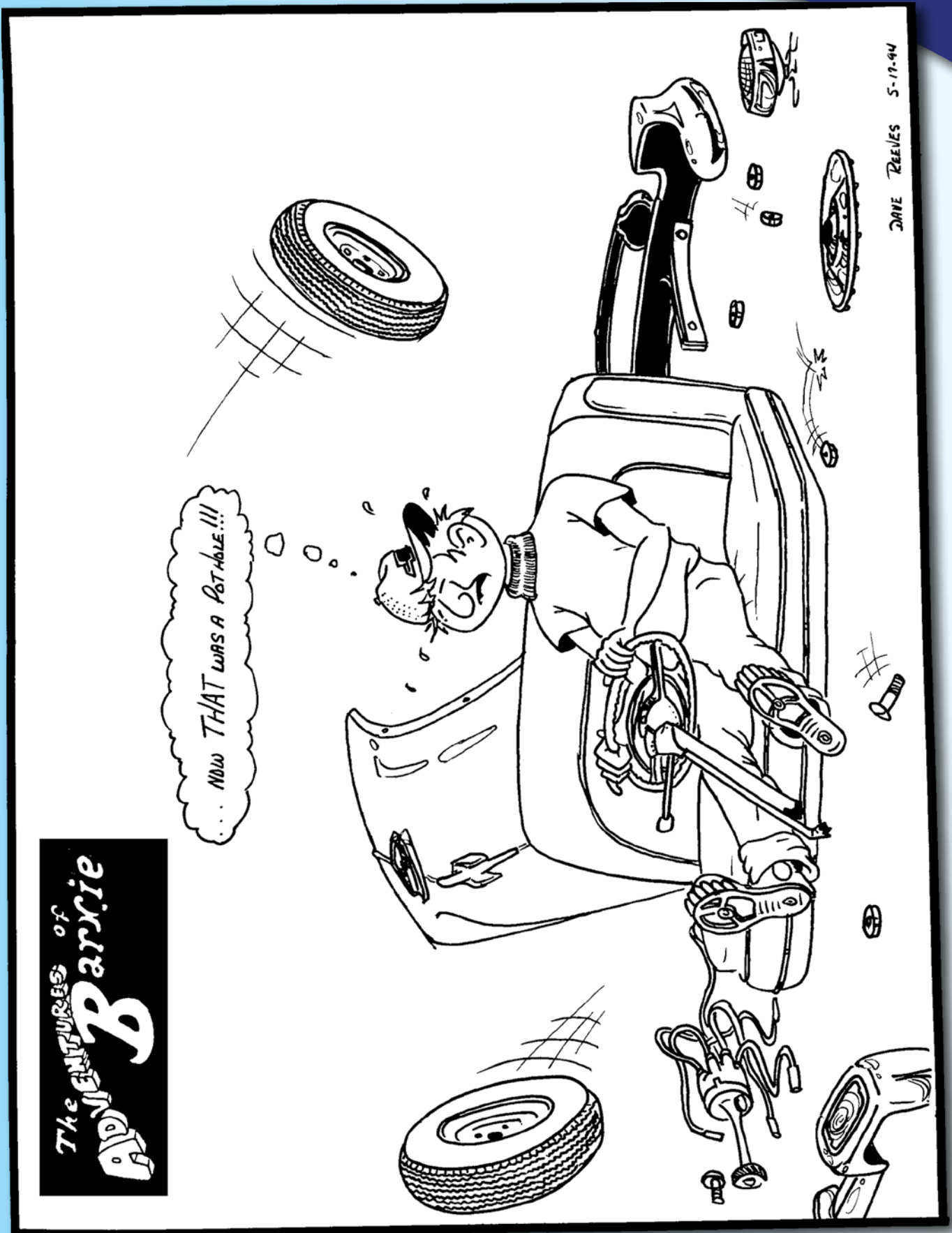

The ADVENTURES of **Barrie**



# 1949-52 DOOR PANEL CARDBOARD

## 2 DOOR STYLELINE

FRONT DOOR PANELS AND REAR SIDE PANELS ..... Order #5044

**\$107<sup>95</sup>**

FRONT DOOR PANELS ONLY ..... Order #5044-1

**\$59<sup>95</sup>**

## 2 DOOR FLEETLINE

FRONT DOOR PANELS AND REAR SIDE PANELS ..... Order #5049

**\$107<sup>95</sup>**

FRONT DOOR PANELS ONLY ..... Order #5044-1

**\$59<sup>95</sup>**

## 4 DOOR STYLELINE

FRONT AND REAR DOOR PANELS ..... Order #5045

**\$107<sup>95</sup>**

FRONT DOOR PANELS ONLY ..... Order #5045-1

**\$59<sup>95</sup>**

## 4 DOOR FLEETLINE

FRONT AND REAR DOOR PANELS ..... Order #5050

**\$107<sup>95</sup>**

FRONT DOOR PANELS ONLY ..... Order #5045-1

**\$59<sup>95</sup>**

## HARDTOP

FRONT DOOR PANELS AND REAR SIDE PANELS ..... Order #5046

**\$107<sup>95</sup>**

## CONVERTIBLE

FRONT DOOR PANELS AND REAR SIDE PANELS ..... Order #5047

**\$104<sup>95</sup>**

## COUPE

FRONT DOOR PANELS AND REAR SIDE PANELS ..... Order #5048

**\$107<sup>95</sup>**

FRONT DOOR PANELS ONLY ..... Order #5044-1

**\$59<sup>95</sup>**

\*Oversize Shipping



These are the waterproof cardboard panels only — there is no fabric on the panels or included with panels.

## 1949-54 DOOR PANEL NAILS

For replacement of broken or missing nails.



ORDER #1013

Set of 25

**\$13<sup>00</sup>**

**NOTE:** If your model is not listed please call for price and availability of door panels for your model. (Sedan Delivery, Station Wagon)

## 1953

### 1953 2 DOOR SEDAN

FRONT DOOR PANELS AND REAR SIDE PANELS (ALL MODELS) ..... Order #1025

**\$92<sup>95</sup>**

FRONT DOOR PANELS ONLY ..... Order #1024

**\$49<sup>95</sup>**

### 1953 4 DOOR SEDAN

FRONT DOOR PANELS AND REAR DOOR PANELS (ALL MODELS) ..... Order #1031

**\$92<sup>95</sup>**

FRONT DOOR PANELS ONLY ..... Order #1030

**\$49<sup>95</sup>**

### 1953 HARDTOP

FRONT DOOR PANELS AND REAR SIDE PANELS ..... Order #1027

**\$92<sup>95</sup>**

### 1953 CONVERTIBLE

FRONT DOOR PANELS AND REAR SIDE PANELS ..... Order #1029

**\$49<sup>95</sup>**

### 1953 CLUB COUPE

FRONT DOOR PANELS AND REAR SIDE PANELS ..... Order #1025CC

**\$92<sup>95</sup>**

FRONT DOOR PANELS ONLY ..... Order #1024

**\$49<sup>95</sup>**

\*Oversize Shipping

# DOOR PANEL CARDBOARDS

## 1954

### 1954 2 DOOR SEDAN

#### FRONT DOOR PANELS AND REAR SIDE PANELS

(Fits 210 Series or 150 Series).....

Order #1025

**\$92<sup>95</sup>**

(Fits BelAir Model).....

Order #1024 BA

**\$92<sup>95</sup>**

#### FRONT DOOR PANELS ONLY

(Fits 210 Series or 150 Series).....

Order #1024

**\$49<sup>95</sup>**

(Fits BelAir Model).....

Order #1028

**\$49<sup>95</sup>**

### 1954 4 DOOR SEDAN

#### FRONT DOOR PANELS AND REAR DOOR PANELS

(Fits 210 Series or 150 Series).....

Order #1031

**\$92<sup>95</sup>**

(Fits BelAir Model) (Also includes pieces that fit along rear seat).....

Order #1031-BA

**\$92<sup>95</sup>**

#### FRONT DOOR PANELS ONLY

(Fits 210 Series or 150 Series).....

Order #1030

**\$49<sup>95</sup>**

(Fits BelAir Model).....

Order #1030-BA

**\$49<sup>95</sup>**

### 1954 HARDTOP

#### FRONT DOOR PANELS AND REAR SIDE PANELS

Order #1027-BA

**\$84<sup>95</sup>**

### 1954 CONVERTIBLE

#### FRONT DOOR PANELS AND REAR SIDE PANELS

Order #1029-BA

**\$84<sup>95</sup>**

\*Oversize Shipping

# METAL DOOR EDGE STRIP KITS

### 2 DOOR SEDAN AND COUPE

Kit includes metal edge strip set for front, back and bottom of both doors and front edge of both rear side panels.  
Fits Styleline and Fleetline models

Order #5040

**\$85<sup>00</sup>**

### HARDTOP / CONVERTIBLE

Kit includes metal edge strips for front, back and bottom of both doors.

Order #5041

**\$74<sup>00</sup>**

### 4 DOOR SEDAN FRONT DOORS

Kit includes metal edge strips for front, back and bottom edge of front doors.  
Fits Styleline and Fleetline models.

Order #5042

**\$74<sup>00</sup>**

### 4 DOOR SEDAN REAR DOORS

Kit includes metal edge strips for front, back and bottom edge of rear doors.  
Fits Styleline and Fleetline models.

Order #5042-1

**\$74<sup>00</sup>**

### SEDAN DELIVERY

Kit includes metal edge strips for front, back and bottom edge of both doors.

Order #5043

**\$74<sup>00</sup>**

### BOTTOM METAL EDGE STRIP ONLY

Hooks to bottom edge of door to hold lower edge of door panel on. May need to be cut to size.

Order #1035

**\$15<sup>ea.</sup>**

1949-52

### 2 DOOR SEDAN AND CLUB COUPE

Kit includes metal edge strips for front, back and bottom of both doors and front edge of both rear side panels.

Order #1022

**\$85<sup>00</sup>**

### 2 DOOR HARDTOP OR CONVERTIBLE

Kit includes metal edge strips for front, back and bottom of both doors.

Order #1023

**\$74<sup>00</sup>**

### SEDAN DELIVERY

Kit includes metal edge strips for front, back and bottom edge of both doors.

Order #1034

**\$74<sup>00</sup>**

### 4 DOOR SEDAN FRONT DOORS

Kit includes metal edge strips for front, back and bottom edge of front doors.

Order #1033

**\$74<sup>00</sup>**

### 4 DOOR SEDAN REAR DOORS

Kit includes metal edge strips for front, back and bottom edge of rear doors.

Order #1033R

**\$74<sup>00</sup>**

### BOTTOM METAL EDGE STRIP ONLY

Hooks to bottom edge of door to hold lower edge of door panel on. May need to be cut to size.

Order #1035

**\$15<sup>ea.</sup>**



USED FOR HOLDING DOOR CARDBOARD PANELS ON. STRIPS ARE PRE-BENT FOR USE. SOLD IN KIT FORM WITH NAILS INCLUDED.

\*Oversize Shipping

1953-54



# 1949-52 DOOR WEATHERSTRIP

**2 DOOR SEDAN** (4 pc. set)  
Exact reproduction with molded ends.  
(Will also fit front doors of 4-door sedan)

ORDER #5001

**\$105<sup>00</sup>** set

**2 DOOR SEDAN**  
(Generic 4-pc. set)

ORDER #5002

**\$54<sup>00</sup>** set

**4 DOOR SEDAN**  
(Generic 8 pc. set)

ORDER #5003

**\$108<sup>00</sup>** set

**SEDAN DELIVERY**

ORDER #5002

**\$50<sup>00</sup>** set

**STATION WAGON REAR DOOR**

ORDER #1004 RD

**\$35<sup>00</sup>** set

**SEDAN DELIVERY REAR DOOR**

ORDER #1005 RD

**\$35<sup>00</sup>** set



**NOTE:** Sedan Delivery and Station Wagon use the same door weatherstrip as 2 and 4 door Sedans.

## SEDAN AUXILIARY WEATHERSTRIP

Weatherstrip attached to car body on "A" post of all sedans.



ORDER #5004 **\$95** pr.

## FRONT FENDER TO DOOR SEALS

Seals front edge of doors to fenders. (Found on all models.) These should be replaced to completely seal your doors.



ORDER #5005 **\$20** pr.

## CONVERTIBLE/HARDTOP AUXILIARY WEATHERSTRIP

Weatherstrip found on lock pillar of car body.



ORDER #5007 **\$40<sup>00</sup>**

## WEATHERSTRIP ADHESIVE

Used to install door or trunk weatherstrip. Many other uses also.



ORDER #812 **\$17<sup>00</sup>** ea.

## DOOR HINGE PINS

Replaces worn pins on front doors only. (Too short for rear door on 4 door.) Requires 2 per door.



ORDER #1067 **\$8<sup>00</sup>** pr.

## DOOR HINGE PIN BUSHINGS

For use with new hinge pins. Requires 4 per door. Made of metal. Fits front or rear doors.

ORDER #1068 **\$12<sup>00</sup>** set of 4

## 1949-52 FRONT OR REAR DOOR CHECK LINK



FRONT DOOR

ORDER #5008 **\$14<sup>00</sup>**

REAR DOOR

ORDER #5009 **\$14<sup>00</sup>**

# DOOR GROMMETS

Replace old painted or missing grommets and bumpers on your car with fresh new ones

## 2 Door Sedan Door Grommet Kit

Does both doors

ORDER #601-1

**\$20<sup>00</sup>**

## 4 Door Sedan Door Grommet Kit

Does all four doors

ORDER #601-4

**\$23<sup>00</sup>**

## Hardtop & Convertible Door Grommet Kit

Does both doors

ORDER #601-2

**\$5<sup>00</sup>**



# 1953-54 DOOR WEATHERSTRIP

<b>2 Door Sedan</b> (2 pc. set) Original style	ORDER #1001	<b>\$45<sup>00</sup></b>	pr.
<b>2 Door Hardtop &amp; Convertible</b> (Generic - 2 pc. set)	ORDER #1002	<b>\$36<sup>00</sup></b>	pr.
<b>4 Door Sedan</b> (4 pc. set)	ORDER #1003	<b>\$90<sup>00</sup></b>	set
<b>Station Wagon</b> (4 pc. set)	ORDER #1004	<b>\$90<sup>00</sup></b>	set
<b>Station Wagon Rear Door</b>	ORDER #1004-RD	<b>\$35<sup>00</sup></b>	set
<b>Sedan Delivery</b> (2 pc. set)	ORDER #1005	<b>\$35<sup>00</sup></b>	pr.
<b>Sedan Delivery Rear Door</b> Correct 2 pc. set	ORDER #1005-RD	<b>\$35<sup>00</sup></b>	set



**(All weatherstrips are made in the U.S.A.)**

## WEATHERSTRIP ADHESIVE

ORDER #812  
**\$17<sup>00</sup>** ea

Used to install door or trunk weatherstrip.  
Many other uses also.



## DOOR HINGE PINS

Replaces worn pins on front doors only.  
(Too short for rear door on 4 door.)  
Requires 2 per door.

ORDER #1067 **\$8<sup>00</sup>** pr.

## DOOR HINGE PIN BUSHING

For use with new hinge pins.  
Requires 4 per door. Made of metal.  
Fits front or rear doors.

ORDER #1068 **\$12<sup>00</sup>** set of 4

# DOOR GROMMETS

Replace old painted or missing grommets and bumpers on your car with fresh new ones.

**2 Door Sedan Door Grommet Kit**  
Does both doors

ORDER #601-1 **\$20<sup>00</sup>**

**4 Door Sedan Door Grommet Kit**  
Does all four doors

ORDER #601-4 **\$23<sup>00</sup>**

**Hardtop & Convertible Door Grommet Kit**  
Does both doors

ORDER #601-2 **\$4<sup>00</sup>**





# TRUNK CARDBOARDS

## 1949-52



Trunk cardboard kit contains 3 piece trunk cardboard liners. (Available in black or brown/taupe.)

ORDER BY YEAR AND MODEL.

**\$68** set

\*Oversize Shipping

### STYLELINE SEDANS

BLACK ..... ORDER #4807-1  
BROWN ..... ORDER #4807-6

### FLEETLINE SEDANS

BLACK ..... ORDER #4807-2  
BROWN ..... ORDER #4807-7

### CONVERTIBLE

BLACK ..... ORDER #4807-3  
BROWN ..... ORDER #4807-8

### BELAIR HARDTOP/COUPE

BLACK ..... ORDER #4807-4  
BROWN ..... ORDER #4807-9

## 1953-54



Trunk cardboard kit contains 3 piece trunk cardboard liners and gas filler tube cover. Color: Black.

2 or 4 Door Sedan - 1953 ..... ORDER #807-3  
Hardtop - 1953 Coupe ..... ORDER #805-3  
Convertible - 1953 ..... ORDER #806-3  
2 or 4 Door Sedan - 1954 ..... ORDER #807-4  
Coupe/Hardtop - 1954 ..... ORDER #805-4  
Convertible - 1954 ..... ORDER #806-4

\*Oversize Shipping

**\$68<sup>00</sup>** set



# CUSTOM CARPET COVERED TRUNK CARDBOARDS

Customize your trunk compartment with this 3-piece trunk cardboard set. Cardboards are covered with a light gray charcoal carpet liner.

## 1949-52

### STYLELINE SEDANS

ORDER #4809-1

### FLEETLINE SEDANS

ORDER #4809-2

### CONVERTIBLE

ORDER #4809-3

### BELAIR HARDTOP/COUPE

ORDER #4809-4



\*Oversize Shipping

**\$98<sup>00</sup>** set

Custom trunk cardboard 3-piece set with light gray carpet liner cover and carpet covered gas filler tube cover.

## 1953-54

1953/54 2 or 4 door Sedan

ORDER #826

1953/54 Hardtop

ORDER #827

1953/54 Convertible

ORDER #828



\*Oversize Shipping

**\$98<sup>00</sup>** set

# TRUNK WEATHERSTRIP

## EXACT REPRODUCTION TRUNK WEATHERSTRIP

Correct lid weatherstrip with molded corners on deck weatherstrip like the original.

2 or 4 Door Sedan **1953-54**  
ORDER #801  
**\$62<sup>00</sup>** Set

Hard Top Convertible  
or Coupe  
ORDER #802  
**\$62<sup>00</sup>** Set



## 1949-52 EXACT REPRODUCTION TRUNK WEATHERSTRIP

ORDER #4602 **\$49** Set



## WEATHERSTRIP ADHESIVE

Use to install door and trunk weatherstrip. Long lasting.



1949-1954

ORDER #812  
**\$17<sup>00</sup>**

# TRUNK LID INSERTS

## 1949-52 TRUNK LID INSERTS

Replacement inner trunk lid panels made in light gray carpet that matches carpet covered trunk cardboards. Sold as set.

'49-52 Styleline  
2 & 4 dr. Sedan

ORDER #4620

**\$20**

'49-52 Styleline,  
Convertible,  
HT Coupe

ORDER #4621

**\$20**

'49-52 Fleetline  
2 & 4 dr. Sedan

ORDER #4622

**\$20**



## 1953-54 TRUNK LID INSERT

Replacement inner trunk lid panels made with light gray carpet liner that matches carpet covered trunk cardboards. Complete set.

SEDAN  
ORDER #806-13

HARDTOP,  
CONV., COUPE  
ORDER #806-14

**\$20** Set



# SPARE TIRE COVER

## 1949-54 CLOTH SPARE TIRE COVER



Available in red, blue, green, black, gray, and tan.

**SPECIFY COLOR.**

Can be ordered to match custom interior.

ORDER #835

**\$35<sup>00</sup>**

## 1949-54 SPARE TIRE COVER



Soft black vinyl with storage pockets.

Fits all 15" tires and gives trunk a nice finished look.

ORDER #815

**\$35<sup>00</sup>**

## TRUNK CARPET

Customize your trunk compartment with this cut pile carpet instead of original rubber mat. Carpet is sewn to fit contour of hump, and binding is used around spare tire well. Fits all models. Also includes carpet pad.

Available in red, blue, green, black, gray, brown, tan, turquoise.

**Specify color & model.**

1949-52 ORDER #4805  
1953-54 ORDER #820

**\$99**

Purchase of #721 Spray Adhesive is recommended for easy installation.



## SPRAY ADHESIVE

Use to glue pad and carpet down.

ORDER #721  
**\$14<sup>00</sup>** ea.





# 1949-52 TRUNK COMPARTMENT

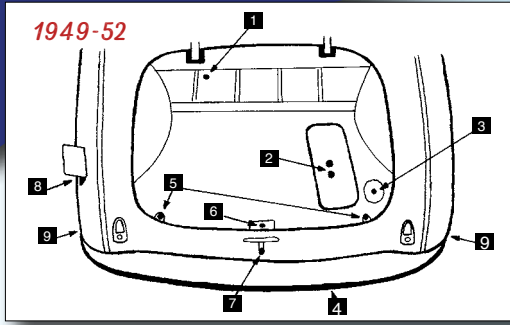

**'50 TRUNK HANDLE TO BODY PAD**  
ORDER #4613



**1 GAS TANK SENDING UNIT WIRE GROMMET**

ORDER #601-13



**4 REAR BUMPER TO GRAVEL PAN SHIELD**

Crimped in lip of rear gravel pan.



ORDER #804

**\$19<sup>00</sup>**

**2 SPARE TIRE WELL PLUGS**

ORDER #601-9

**\$16<sup>00</sup>** pr.



**5 '49-50 TRUNK LID BUMPERS**

ORDER #4601-3

**\$4<sup>00</sup>** pr.



**5A '51-52 TRUNK LID BUMPERS**



ORDER #4601-4

**\$4<sup>00</sup>** pr.

**3 PLUG FOR INDENT NEXT TO TIRE WELL**

ORDER #601-16

**\$3<sup>00</sup>** ea.



**6 FLOOR PAN/ TRUNK FLOOR PLUG**

Fits 1/2" hole.

ORDER #601-15

**\$3<sup>00</sup>** ea.



**7 REAR LICENSE PLATE BRACKET GROMMET**

Fits on bumper behind license plate to prevent rattle.

ORDER #4601-7

**\$4<sup>00</sup>** pr.



**8 GAS DOOR GROMMETS**

Includes Screws

ORDER #601-6

**\$6<sup>00</sup>** pr.

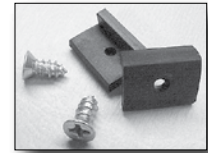

**9 REAR BUMPER ARM GROMMETS**

ORDER #4601-9

**\$11<sup>00</sup>** pr.



# DELUXE COMPLETE TRUNK KIT

**New**

## SUPER DELUXE COMPLETE TRUNK KIT

For a great looking trunk compartment check out this new kit. It includes:

- 20 oz. carpet pad, already glued to Easy Care Carpet for easy installation
- Matching carpet covered cardboard side panels
- Spare tire cover
- Trunk lid inserts
- Spare tire well liner
- Great sound proofing
- Water resistant

**1949-52 SEDAN ORDER #896-DLX**

**1949-52 CONVERTIBLE, COUPE, HARDTOP ORDER #897-DLX**

**1953-54 2 OR 4 DOOR SEDAN ORDER #899-DLX**

**1953-54 HARDTOP, CONVERTIBLE, COUPE ORDER #898-DLX**



Specify Color

Only

**\$239** Kit



Fabric is soft and easy to work with. Same material is used on all items in kit. Please call for fabric sample. **Complete kits only.** Available in tan, which brightens up the trunk compartment. Other colors are available. Call us.

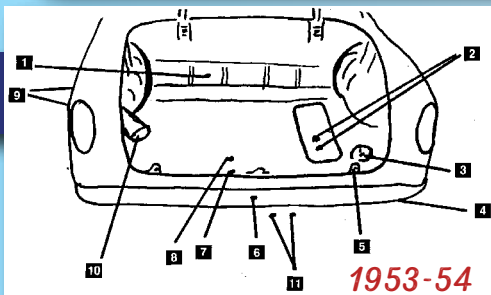

## 1953-54 TRUNK COMPARTMENT

**1 Sending Wire Grommet**  
ORDER #601-13  
**\$11<sup>00</sup>**

**2 Spare Tire Plugs**  
ORDER #601-9  
**\$16** pr.

**3 Plug for Indent Next to Tire Well**  
ORDER #601-16  
**\$3<sup>00</sup>** ea.

**5 Trunk Lid Bumpers**  
ORDER #601-3  
**\$7<sup>00</sup>** pr.

**6 License Light Wire Grommet in Gravel Pan**  
ORDER #601-11  
**\$3<sup>00</sup>** ea.

**4 Rear Bumper to Gravel Pan Seal**  
Fits between rear splash pan and rear bumper  
ORDER #804  
**\$21<sup>00</sup>**

**7 License Light Wire in Trunk Floor**  
ORDER #601-12  
**\$9** ea.

**8 Floor Pan Plug**  
ORDER #601-15  
**\$3** ea.

**9A Gas Door Grommet**  
ORDER #601-6  
**\$6** Includes Screws

**9B Fuel Filler Neck Grommet (SED. DEL./STN. WGN.)**  
ORDER #829  
**\$60**

**10 Gas Filler Tube Cover**  
(Covers gas tube in trunk)  
ORDER #814  
**\$5<sup>00</sup>**

**1953 JACK TAG**  
ORDER #210  
**\$6<sup>00</sup>**

**1954 JACK TAG**  
ORDER #211  
**\$6<sup>00</sup>**

**1953-54 REAR GRAVEL PAN INSTALLATION KIT**  
ORDER #1903  
**\$9<sup>00</sup>**

**11 Rear License Plate Grommet**  
Fits on bumper behind license plate to prevent rattle.  
ORDER #601-7  
**\$4<sup>00</sup>** pr.





*Bill  
Indiana*



*Adrien  
Australia*



*Gary  
Wisconsin*



*Ron  
Illinois*

# The Adventures of **Barnie**

GEE MIKE, I DIDN'T KNOW YOU WERE BUILDING A LOW RIDER!

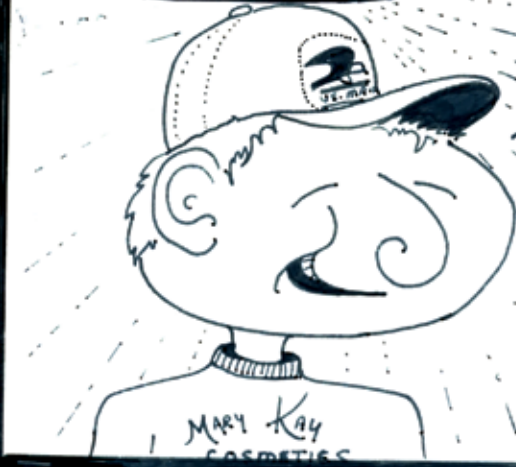

I'm NOT.... ITS' JUST SAGGIN' FROM ALL THE WEIGHT!

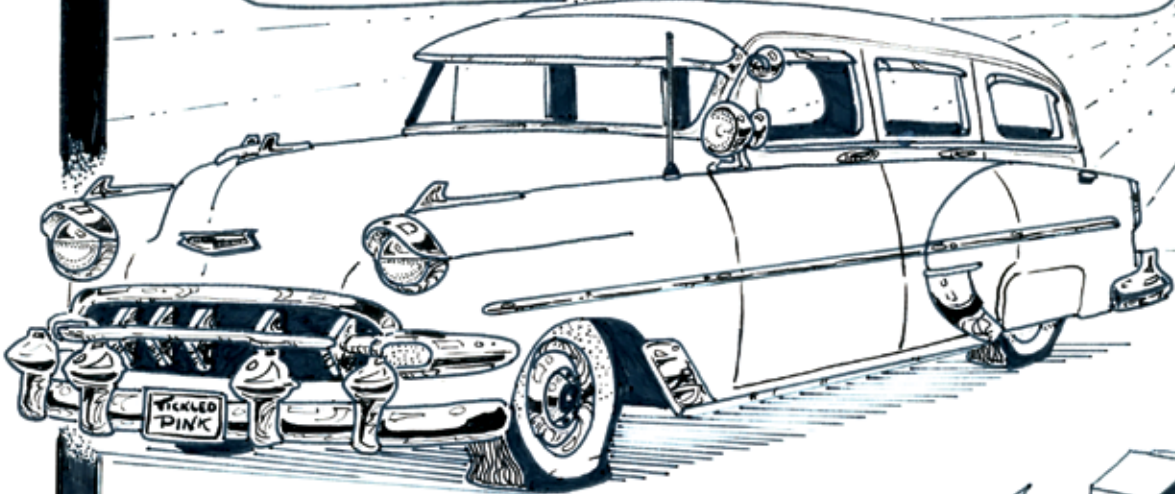



# 1949-52 REPLACEMENT SIDE WINDOW GLASS

Glass is cut to size and will replace clear or tinted original glass, but it does not have the insignia or date code. Be sure to specify car model and specify clear or tinted. Please note: Tinted glass is a light green shade.

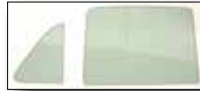

**GREEN**



**CLEAR**



**GRAY**

## STYLELINE 2 DOOR SEDAN



6 pc. side glass set	TINTED Order #6300T	CLEAR Order #6300C	GRAY Order #6300S	<b>\$339<sup>00</sup></b>
Vent (ea)	TINTED Order #6310T	CLEAR Order #6310C	GRAY Order #6310S	<b>\$25<sup>00</sup></b>
Door (ea)	TINTED Order #6311T	CLEAR Order #6311C	GRAY Order #6311S	<b>\$72<sup>00</sup></b>
Rear Side (ea)	TINTED Order #6312T	CLEAR Order #6312C	GRAY Order #6312S	<b>\$72<sup>00</sup></b>

## STYLELINE 4 DOOR SEDAN

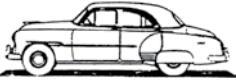

8 pc. side glass set (Deluxe with opening rear door vent)	TINTED Order #6301T	CLEAR Order #6301C	GRAY Order #6301S	<b>\$339<sup>00</sup></b>
8 pc. side glass set (Special with fixed rear door vent)	TINTED Order #6302T	CLEAR Order #6302C	GRAY Order #6302S	<b>\$339<sup>00</sup></b>
Front Door Vent (ea)	TINTED Order #6310T	CLEAR Order #6310C	GRAY Order #6310S	<b>\$25<sup>00</sup></b>
Front Door (ea)	TINTED Order #6313T	CLEAR Order #6313C	GRAY Order #6313S	<b>\$72<sup>00</sup></b>
Rear Door (ea)	TINTED Order #6314T	CLEAR Order #6314C	GRAY Order #6314S	<b>\$72<sup>00</sup></b>
Rear Door Vent (ea) (Deluxe Opening)	TINTED Order #6315T	CLEAR Order #6315C	GRAY Order #6315S	<b>\$25<sup>00</sup></b>
Rear Door Vent (ea) (Special - Fixed)	TINTED Order #6316T	CLEAR Order #6316C	GRAY Order #6316S	<b>\$25<sup>00</sup></b>

## FLEETLINE 2 DOOR SEDAN



6 pc. side glass set	TINTED Order #6303T	CLEAR Order #6303C	GRAY Order #6303S	<b>\$339<sup>00</sup></b>
Vent (ea)	TINTED Order #6317T	CLEAR Order #6317C	GRAY Order #6317S	<b>\$25<sup>00</sup></b>
Door (ea)	TINTED Order #6318T	CLEAR Order #6318C	GRAY Order #6318S	<b>\$72<sup>00</sup></b>
Rear Side (ea)	TINTED Order #6319T	CLEAR Order #6319C	GRAY Order #6319S	<b>\$72<sup>00</sup></b>

## FLEETLINE 4 DOOR SEDAN



8 pc. side glass set (Deluxe with opening rear door vent)	TINTED Order #6304T	CLEAR Order #6304C	GRAY Order #6304S	<b>\$339<sup>00</sup></b>
8 pc. side glass set (Special with fixed rear door vent)	TINTED Order #6305T	CLEAR Order #6305C	GRAY Order #6305S	<b>\$339<sup>00</sup></b>
Front Door Vent (ea)	TINTED Order #6317T	CLEAR Order #6317C	GRAY Order #6317S	<b>\$25<sup>00</sup></b>
Front Door (ea)	TINTED Order #6323T	CLEAR Order #6323C	GRAY Order #6323S	<b>\$72<sup>00</sup></b>
Rear Door (ea)	TINTED Order #6324T	CLEAR Order #6324C	GRAY Order #6324S	<b>\$72<sup>00</sup></b>
Rear Door Vent (ea) (Deluxe Opening)	TINTED Order #6325T	CLEAR Order #6325C	GRAY Order #6325S	<b>\$25<sup>00</sup></b>
Rear Door Vent (ea) (Special - Fixed)	TINTED Order #6326T	CLEAR Order #6326C	GRAY Order #6326S	<b>\$25<sup>00</sup></b>

## CONVERTIBLE/50-52 BELAIR HARDTOP

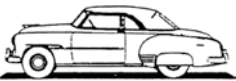

6 pc. side glass set	TINTED Order #6306T	CLEAR Order #6306C	GRAY Order #6306S	<b>\$339<sup>00</sup></b>
Vent (ea)	TINTED Order #6327T	CLEAR Order #6327C	GRAY Order #6327S	<b>\$25<sup>00</sup></b>
Door (ea)	TINTED Order #6328T	CLEAR Order #6328C	GRAY Order #6328S	<b>\$72<sup>00</sup></b>
Rear Side (ea)	TINTED Order #6329T	CLEAR Order #6329C	GRAY Order #6329S	<b>\$72<sup>00</sup></b>

## STYLELINE COUPE



6 pc. side glass set (Stationary Rear)	TINTED Order #6307T	CLEAR Order #6307C	GRAY Order #6307S	<b>\$339<sup>00</sup></b>
6 pc. side glass set (Sliding Rear)	TINTED Order #6308T	CLEAR Order #6308C	GRAY Order #6308S	<b>\$339<sup>00</sup></b>
Vent (ea)	TINTED Order #6310T	CLEAR Order #6310C	GRAY Order #6310S	<b>\$25<sup>00</sup></b>
Door (ea)	TINTED Order #6332T	CLEAR Order #6332C	GRAY Order #6332S	<b>\$72<sup>00</sup></b>
Stationary Rear Side (ea)	TINTED Order #6330T	CLEAR Order #6330C	GRAY Order #6330S	<b>\$72<sup>00</sup></b>
Sliding Rear Side (ea)	TINTED Order #6331T	CLEAR Order #6331C	GRAY Order #6331S	<b>\$72<sup>00</sup></b>

## SEDAN DELIVERY



4 pc. side glass set	TINTED Order #6309T	CLEAR Order #6309C	GRAY Order #6309S	<b>\$224<sup>00</sup></b>
Vent (ea)	TINTED Order #6310T	CLEAR Order #6310C	GRAY Order #6310S	<b>\$25<sup>00</sup></b>
Door (ea)	TINTED Order #6313T	CLEAR Order #6313C	GRAY Order #6313S	<b>\$72<sup>00</sup></b>

# 1949-52 REPLACEMENT SIDE WINDOW GLASS

**TINT**

**CLEAR**

**GRAY**

## STATION WAGON - 1949-52 "TIN WOODY"

**THIS IS THE STEEL MODEL**

10 pc. side glass set .....	TINTED Order #6354T .....	CLEAR Order #6354C .....	GRAY Order #6354S	<b>\$529<sup>00</sup></b>
Vent (ea).....	TINTED Order #6310T .....	CLEAR Order #6310C .....	GRAY Order #6310S	<b>\$25<sup>00</sup></b>
Front Door (ea) .....	TINTED Order #6350T .....	CLEAR Order #6350C .....	GRAY Order #6350S	<b>\$72<sup>00</sup></b>
Rear Door (ea) .....	TINTED Order #6351T .....	CLEAR Order #6351C .....	GRAY Order #6351S	<b>\$72<sup>00</sup></b>
Rear Quarter Fixed (ea) .	TINTED Order #6352T .....	CLEAR Order #6352C .....	GRAY Order #6352S	<b>\$72<sup>00</sup></b>
Rear Quarter Slider (ea) .	TINTED Order #6353T .....	CLEAR Order #6353C .....	GRAY Order #6353S	<b>\$72<sup>00</sup></b>

## STATION WAGON - EARLY 1949 "WOODY"

10 pc. side glass set .....	TINTED Order #6359T .....	CLEAR Order #6359C .....	GRAY Order #6359S	<b>\$539<sup>00</sup></b>
Vent (ea).....	TINTED Order #6310T .....	CLEAR Order #6310C .....	GRAY Order #6310S	<b>\$25<sup>00</sup></b>
Front Door (ea) .....	TINTED Order #6355T .....	CLEAR Order #6355C .....	GRAY Order #6355S	<b>\$72<sup>00</sup></b>
Rear Door (ea) .....	TINTED Order #6356T .....	CLEAR Order #6356C .....	GRAY Order #6356S	<b>\$72<sup>00</sup></b>
Rear Quarter Fixed (ea) .	TINTED Order #6357T .....	CLEAR Order #6357C .....	GRAY Order #6357S	<b>\$72<sup>00</sup></b>
Rear Quarter Slider (ea) .	TINTED Order #6358T .....	CLEAR Order #6358C .....	GRAY Order #6358S	<b>\$72<sup>00</sup></b>

# WINDSHIELD

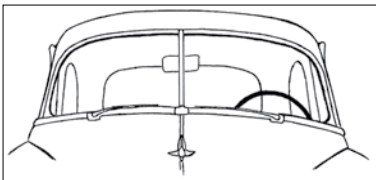

Replace your windshield for a complete restoration. New glass can make a world of difference in the appearance of your car, not to mention that chips and scratches can impair your vision. Available in tint only. **1949-52 Windshields are 2 pieces, and cannot be sold separately.** 1953-54 Windshields are one piece.



<b>1949-52 STYLELINE SEDANS, COUPE, SEDAN DELIVERY</b> .....	Order #6320	<b>\$395<sup>00</sup></b> SET
<b>1949-52 FLEETLINE SERIES</b> .....	Order #6321	<b>\$395<sup>00</sup></b> SET
<b>1949-52 BEL AIR HARDTOP/CONVERTIBLE</b> .....	Order #6322	<b>\$395<sup>00</sup></b> SET
<b>1953-54 2- OR 4-DOOR SEDAN</b> .....	Order #2320	<b>\$450<sup>00</sup></b> SET
<b>1953-54 HARDTOP/CONVERTIBLE</b> .....	Order #2321	<b>\$450<sup>00</sup></b> SET
<b>1953-54 STATION WAGON</b> .....	Order #2322	<b>\$450<sup>00</sup></b> SET
<b>1949-52 STATION WAGON</b> .....	Order #6375	<b>\$425<sup>00</sup></b> SET

## 1949-52 VENTSHADES

Reproduction of original ventshades.  
Fits 1949-52 **4-DOOR** Styleline or Styleline Deluxe.

ORDER #2344  
**\$115** set



## 1949-52 WINDSHIELD CENTER DIVIDER NUTS AND BOLTS

**NOTE:** Stainless Divider not included.

ORDER #5907

**\$18** set





# 1953-54 REPLACEMENT SIDE WINDOW GLASS

Glass is cut to size and will replace clear or tinted original glass, but it does not have the insignia or date code. Be sure to specify car model and specify clear or tinted. Please note: Tinted glass is a light green shade. Smoke is great for your custom car!



## 2-DOOR SEDAN

6 PC. SIDE GLASS SET  
VENT (EA.)  
DOOR (EA.)  
REAR SIDE (EA.)

**150 SERIES  
CLEAR**

#2300C  
#2301C  
#2302C  
#2303C

**210/BELAIR SERIES  
TINTED**

#2300T  
#2301T  
#2302T  
#2303T

**SMOKE  
(GRAY GLASS)**

2300S  
2301S  
2302S  
2303S

**\$339.00**  
**\$25.00**  
**\$72.00**  
**\$72.00**



## 4-DOOR SEDAN

6-PC. SIDE GLASS SET  
VENT (EA.)  
FRONT DOOR (EA.)  
REAR DOOR (EA.)

#2304C  
#2301C  
#2305C  
#2306C

#2304T  
#2301T  
#2305T  
#2306T

2304S  
2301S  
2305S  
2306S

**\$339.00**  
**\$25.00**  
**\$72.00**  
**\$72.00**



## 2-DOOR HARDTOP

6-PC. SIDE GLASS SET  
VENT (EA.)  
DOOR (EA.)  
REAR QUARTER (EA.)

#2307C  
#2308C  
#2309C  
#2310C

#2307T  
#2308T  
#2309T  
#2310T

2307S  
2308S  
2309S  
2310S

**\$339.00**  
**\$25.00**  
**\$72.00**  
**\$72.00**

*(NOTE: Special order only on clear glass)*



## CONVERTIBLE

6-PC. SIDE GLASS SET  
VENT (EA.)  
DOOR (EA.)  
REAR QUARTER (EA.)

#2311C  
#2308C  
#2309C  
#2312C

#2311T  
#2308T  
#2309T  
#2312T

2311S  
2308S  
2309S  
2312S

**\$339.00**  
**\$25.00**  
**\$72.00**  
**\$72.00**

*(NOTE: Special order only on clear glass)*



## 2-DOOR COUPE

6-PC. SIDE GLASS SET  
(REAR FIXED WINDOW)  
6 PC. SIDE GLASS SET  
(SLIDING REAR WINDOW)  
VENT (EA.)  
DOOR (EA.)  
REAR FIXED (EA.)  
REAR SLIDING (EA.)

#2313FC  
#2313SC  
#2301C  
#2302C  
#2314C  
#2315C

#2313FT  
#2313ST  
#2301T  
#2302T  
#2314T  
#2315T

2313FS  
2313SS  
2301S  
2302S  
2314S  
2315S

**\$399.00**  
**\$399.00**  
**\$25.00**  
**\$72.00**  
**\$72.00**  
**\$72.00**



## SEDAN DELIVERY

4-PC. SIDE GLASS SET  
VENT (EA.)  
DOOR (EA.)

#2316C  
#2301C  
#2305C

#2316T  
#2301T  
#2305T

2316S  
2301S  
2305S

**\$224.00**  
**\$25.00**  
**\$72.00**

## STATION WAGON

TOWNSMAN WAGON 10-PC. SET  
HANDYMAN WAGON 8-PC. SET  
VENT (EA.)  
FRONT DOOR (EA.)  
REAR DOOR (EA.)  
TOWNSMAN REAR QUARTER FIXED (EA.)  
TOWNSMAN REAR QUARTER SLIDER (EA.)  
HANDYMAN REAR QUARTER FIXED (EA.)

#2330C  
#2331C  
#2301C  
#2325C  
#2326C  
#2327C  
#2328C  
#2329C

#2330T  
#2331T  
#2301T  
#2325T  
#2326T  
#2327T  
#2328T  
#2329T

2330S  
2331S  
2301S  
2325S  
2326S  
2327S  
2328S  
2329S

**\$547.00**  
**\$499.00**  
**\$25.00**  
**\$72.00**  
**\$72.00**  
**\$72.00**  
**\$72.00**  
**\$90.00**

# REAR GLASS

*New*

We now have back glass for most models. They are all available in clear, tint or smoke.



1949-52 Fleetline



1950-52 BelAir



1949-52 Styleline



1953-54 Hardtop

CLEAR

TINTED

SMOKE

	<u>CLEAR</u>	<u>TINTED</u>	<u>SMOKE</u>	
<b>1949-54 SEDAN DELIVERY REAR DOOR GLASS</b> Available in clear, tint, smoke.	#6340	#6340-T	#6340-S	<b>\$275.00</b>
<b>1949-52 FLEETLINE BACK GLASS</b>	#6341	#6341-T	#6341-S	<b>\$275.00</b>
<b>1949-52 STYLELINE BUSINESS AND SPORT COUPE BACK GLASS</b>	#6342	#6342-T	#6342-S	<b>\$275.00</b>
<b>1949-52 STYLELINE SEDAN BACK GLASS</b>	#6343	#6343-T	#6343-S	<b>\$275.00</b>
<b>1950-52 BELAIR HARDTOP BACK GLASS (3 pc)</b>	#6344	#6344-T	#6344-S	<b>\$399.00</b>
<b>1953 150 SERIES (2/4 DR. SEDAN, BUSINESS COUPE, CLUB COUPE) BACK GLASS</b>	#6345	#6345-T	#6345-S	<b>\$399.00</b>
<b>1953-54 210 AND BELAIR SERIES, 2 &amp; 4 DOOR SEDAN BACK GLASS</b>	#6346	#6346-T	#6346-S	<b>\$399.00</b>
<b>1953-54 HARDTOP (SPORT COUPE) BACK GLASS</b>	#6347	#6347-T	#6347-S	<b>\$399.00</b>

## HARDTOP/CONVERTIBLE WINDOW FRAMES

### 1949-52 BELAIR HARDTOP/CONVERTIBLE CHROME WINDOW FRAMES

Beautiful reproductions of chrome side window frames for hardtop/convertible.  
Excellent plating!



DRIVER DOOR OR PASSENGER DOOR  
ORDER #5034

REAR QUARTER WINDOW  
UPPER FRAME

Will fit either side, 2 per car.

ORDER #5035

**\$90<sup>00</sup>** ea.

### 1953-54 HARDTOP/CONVERTIBLE FRONT DOOR WINDOW FRAME

Fits either side. Replace your rusty window frames with these new reproductions. Excellent plating.

ORDER #1078 **\$90<sup>00</sup>** ea.

### 1953-54 CONVERTIBLE REAR QUARTER WINDOW UPPER FRAME

Beautiful chrome finish on this excellent reproduction.

Will fit either side.

ORDER #1077 **\$90<sup>00</sup>** ea.



# 1949-52 WINDSHIELD AND REAR GLASS CHANNEL

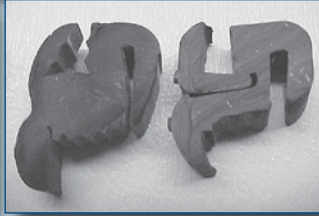

## ALL AROUND AUTO BODY SEALANT

The correct sealant to seal the window gasket to car body.  
Helps prevent annoying leaks.

ORDER #925 **\$30<sup>00</sup>**

## 1949-52 WINDSHIELD CHANNEL

Made in the U.S.A.

### STYLELINE SEDAN AND COUPE



Without Stainless Slot (Special Models) ..... Order #4901  
With Stainless Slot (Deluxe and Sedan Delivery Models)..... Order #4902

### FLEETLINE



Without Stainless Slot (1949-51 Special Models) ..... Order #4903  
With Stainless Slot (Deluxe Models)..... Order #4904

### CONVERTIBLE/BEL AIR HARDTOP



With Stainless Slot ..... Order #4905

### STATION WAGON DELUXE



With Stainless Slot ..... Order #4906

## 1949-52 REAR GLASS CHANNEL

### STYLELINE SEDAN



Without Stainless Slot (Special Models)..... Order #4907  
With Stainless Slot (Deluxe Models) ..... Order #4908

### STYLELINE COUPE



Without Stainless Slot (Special Models)..... Order #4909  
With Stainless Slot (Deluxe Models) ..... Order #4910

### FLEETLINE



Without Stainless Slot (1949-51 Special Models) ..... Order #4911  
With Stainless Slot (Deluxe Models) ..... Order #4912

### BEL AIR HARDTOP



With Stainless Slot ..... Order #4913

### STATION WAGON DELUXE



With Stainless Slot (Tailgate window, except "Woodies") ..... Order #4914

### SEDAN DELIVERY SPECIAL



With Stainless Slot (Rear door window) ..... Order #4915

## 1949-52 COUPE STATIONARY REAR QUARTER WINDOW GASKETS

Correct one piece gaskets to install rear quarter windows.

ORDER #5032

**\$120<sup>00</sup>** pr.



# 1953-54 WINDSHIELD/REAR GLASS CHANNEL

This is exact reproduction one-piece molded channel. Looks and fits great. American made too!



## 1953-1954 WINDSHIELD CHANNEL

- 2 or 4 door sedans, sedan delivery (with slot for stainless trim) ..... ORDER #903
- (without slot for stainless trim) ..... ORDER #901
- Hardtop and convertible windshield channel ..... ORDER #902
- Station wagon windshield glass channel — Correct style (sold in straight length with slot for stainless trim) ..... ORDER #910
- (sold in straight length without slot for stainless trim) ..... ORDER #909

## 1953-1954 REAR GLASS CHANNEL

- 2 or 4 door sedans (except 1953 150 Series 2 door sedan) **SEE BELOW** ..... ORDER #905
- 2 or 4 door sedans (with slot for stainless trim) ..... ORDER #906
- 2 or 4 door sedans, sedan delivery (without slot for stainless trim) ..... ORDER #904
- Hardtop rear glass channel ..... ORDER #907
- Sedan delivery rear door glass channel — Correct style sold in straight length (with slot for stainless trim) ..... ORDER #908
- (without slot for stainless trim) ..... ORDER #908

## REAR WINDOW CHANNEL FOR 1953 150 SEDAN AND 2-DOOR COUPE

(The 1953 150 Series 2 or 4-door Sedan will use the same rear window channel as the 2-door Coupes.)

- Exact reproduction one-piece glass channel (With Slot for Stainless Trim) ..... ORDER #914
- (Without Slot for Stainless Trim) ..... ORDER #913
- Correct channel sold in straight length (With Slot for Stainless Trim) ..... ORDER #912
- (Without Slot for Stainless Trim) ..... ORDER #911

## 1953 COUPE STATIONARY WINDOW GASKETS



Stationary (fixed) rear quarter window gaskets

ORDER #926  
**\$160** pr.

## ALL AROUND AUTO BODY SEALANT

The correct sealant to seal the window gasket to the car body. Will help to prevent annoying and nagging leaks. 10-oz. Tube.

ORDER #925  
**\$30<sup>00</sup>**



## REAR WINDOW CHANNEL FOR 1953-54 STATION WAGON AND SEDAN DELIVERY

### STATION WAGON REAR TAILGATE WINDOW GLASS GASKET

(Except Woodies)

ORDER #928



### SEDAN DELIVERY REAR WINDOW GASKET

(150 Model with Stainless)

ORDER #929





# WINDOW CHANNEL KITS

## 1949-52 Cars

Most of the window channel is an exact reproduction of the original channel used. Channel kits include window channel, belt weatherstrips, division bar or channel liner. Each kit contains all the material required to do all 4 side windows, installation instructions included.

<b>2 DOOR SEDAN</b> .....	Order #1038	<b>\$219<sup>00</sup></b>
<b>4 DOOR SEDAN</b> .....	Order #4039	<b>\$211<sup>00</sup></b>
<b>COUPE</b> (Stationary Rear Quarter Windows ) (F. Doors).....	Order #1043	<b>\$119<sup>00</sup></b>
<b>COUPE</b> (Sliding Rear Quarter Windows) .....	Order #1044	<b>\$183<sup>00</sup></b>
<b>BELAIR HARDTOP/ CONVERTIBLE</b> .....	Order #1040	<b>\$69<sup>00</sup></b>
<b>STATION WAGON</b> .....	Order #1042	<b>\$311<sup>00</sup></b>
<b>SEDAN DELIVERY</b> (Front Doors) .....	Order #1045	<b>\$111<sup>00</sup></b>



\*Oversize Shipping

## 1953-54 Cars

Most of the window channel is an exact reproduction of the original channel used. Channel kits include window channel, belt weather strip, division bar or channel liner. Everything you need to do the side glass on your car. Order kits by car type, 2 door, sedan, hardtop, etc.

<b>2 DR. SEDAN</b>	ORDER #1038	<b>\$219<sup>00</sup></b>	<b>STATION WAGON</b>	ORDER #1042	<b>\$311<sup>00</sup></b>
<b>4 DR. SEDAN</b>	ORDER #1039	<b>\$219<sup>00</sup></b>	w/Sliding Rear Window		
<b>HDTP. &amp; CONV.*</b>	ORDER #1040	<b>\$69<sup>00</sup></b>	<b>COUPE</b>	ORDER #1043	<b>\$119<sup>00</sup></b>
<b>STATION WGN.</b>	ORDER #1041	<b>\$215<sup>00</sup></b>	(with fixed rear window)		
			<b>COUPE</b>	ORDER #1044	<b>\$183<sup>00</sup></b>
			(with sliding rear window)		
			<b>SEDAN DELIVERY</b>	ORDER #1045	<b>\$111<sup>00</sup></b>
			(front doors)		

\*Includes channel liner for backs of front doors, and lower channels for rear qtr. windows)

INSTALLATION INSTRUCTIONS INCLUDED.

\*Oversize Shipping

### WINDOW CHANNEL

Rubber backed flexible channel with stainless bead. 6 ft. pc. will do one window.



ORDER #1018

**\$35<sup>00</sup>** ea.

\*Oversize Shipping

### DIVISION BAR

Rigid channel that runs vertically up and down the back side of vent window assemblies. 2-3 ft. pieces will do 2 windows.



ORDER #1017

**\$19<sup>00</sup>** ea.

### 1949-54 HARDTOP REAR QUARTER WINDOW UPPER CHANNEL "FUZZIES"



Wide belt weatherstrip found in upper window channel of hardtops. 4 -24" pcs. will do one

car. (Not included in #1040 kit.)

ORDER #1080

**\$34<sup>00</sup>** set

### BELT WEATHERSTRIP

"Fuzzy" strip w/stainless bead. Runs horizontally across the top edge of door and on inside garnish moldings. Window rolls up between them. 6 ft. pc. will do one window.



Flexible Pile Lining Rubber-Covered

ORDER #1020

**\$20<sup>00</sup>** ea.

# PRE-BENT WINDOW CHANNEL KITS

This kit contains all channel, belt weatherstrip and division bar to replace old worn parts.  
All channel and belt weatherstrip is pre-bent for easy installation.

## 1949-52 Cars

<b>2 DOOR SEDAN STYLELINE</b> Order #1038-PB .....	<b>\$272</b>	<b>SEDAN DELIVERY</b> Order #1045-PB .....	<b>\$202</b>
<b>4 DOOR SEDAN STYLELINE</b> Order #4039-PB .....	<b>\$288</b>	<b>2 DOOR FLEETLINE</b> Order #4040-PB .....	<b>\$272</b>
<b>COUPE</b> (with fixed rear window) Order #1043-PB .....	<b>\$199</b>	<b>4 DOOR FLEETLINE</b> Order #4042-PB .....	<b>\$288</b>
<b>STATION WAGON</b> (Doors only pre-bent) Order #1041-PB .....	<b>\$380</b>	<b>COUPE</b> (with sliding rear window) Order #1044 .....	<b>\$183</b>

## 1953-54 Cars

<b>2 DOOR SEDAN</b> Order #1038-PB .....	<b>\$272<sup>00</sup></b>		<b>COUPE</b> with Fixed Rear Window Order #1043-PB-53 .....	<b>\$172<sup>00</sup></b>
<b>4 DOOR SEDAN</b> Order #1039-PB .....	<b>\$272<sup>00</sup></b>		<b>COUPE</b> with Sliding Rear Window Order #1044-PB .....	<b>\$183<sup>00</sup></b>
<b>STATION WAGON</b> (Doors only pre-bent) Order #1041-PB .....	<b>\$272<sup>00</sup></b>		<b>SEDAN DELIVERY</b> Order #1045-PB .....	<b>\$202<sup>00</sup></b>
<b>STATION WAGON</b> with Sliding Rear Window (Doors only pre-bent) Order #1042-PB .....	<b>\$340<sup>00</sup></b>			

# GLASS TRACKS

## 1949-52 GLASS TRACK

This is the metal piece that the glass sets in. Held in place by a rubber strip which is included with track. An excellent new part - essential to the smooth operation of your window.

2 dr. Fleetline/Styleline front door driver side .....	Order #5051L
2 dr. Fleetline/Styleline front door pass side .....	Order #5051R
2 dr. Styleline rear side driver side .....	Order #5052L
2 dr. Styleline rear side pass side .....	Order #5052R
2 dr. Fleetline rear side driver side .....	Order #5055L
2 dr. Fleetline rear side pass side .....	Order #5055R
4 dr. Fleetline/Styleline front door driver side .....	Order #5053L
4 dr. Fleetline/Styleline front door pass side .....	Order #5053R
4 dr. Styleline rear door driver side .....	Order #5054L
4 dr. Styleline rear door pass side .....	Order #5054R
4 dr. Fleetline rear door driver side .....	Order #5056L
4 dr. Fleetline rear door pass side .....	Order #5056R
Station Wagon rear door driver side .....	Order #5054LSW
Station Wagon rear door pass side .....	Order #5054RSW



Only **\$49<sup>00</sup>** ea.



# GLASS TRACKS

## 1953-54 GLASS TRACK

This is the metal piece that the glass sets in. Held in place by a rubber strip which is included with track. An excellent new part - essential to the smooth operation of your window.

2 dr. Sedan driver side door .....	Order #1070L
2 dr. Sedan passenger side door .....	Order #1070R
2 dr. Sedan rear driver side .....	Order #1081L
2 dr. Sedan rear passenger side .....	Order #1081R
4 dr. Sedan front door driver side .....	Order #1082L
4 dr. Sedan front door passenger side .....	Order #1082R
4 dr. Sedan rear door driver side .....	Order #1083L
4 dr. Sedan rear door passenger side .....	Order #1083R
2 dr. hardtop/conv. driver side door .....	Order #1071L
2 dr. hardtop/conv. passenger side door .....	Order #1071R
4 dr. station wagon front door driver side .....	Order #1082L-SW
4 dr. station wagon front door passenger door .....	Order #1082R-SW
4 dr. station wagon rear door driver side .....	Order #1083L-SW
4 dr. station wagon rear door passenger side .....	Order #1083R-SW



*Only* **\$49<sup>00</sup>** ea.

## 1949-52 HARDTOP OR CONVERTIBLE GLASS TRACKS

### 1950-52 HARDTOP

Driver side door .....	Order #5057L
Passenger side door .....	Order #5057R

### 1949-52 CONVERTIBLE

Driver side door .....	Order #5057L
Passenger side door .....	Order #5057R

**\$80<sup>00</sup>** ea.



## 1949-52 VENT WINDOW HANDLE

Fits front or rear doors on all Styleline or Fleetline 2 or 4 door Sedans.

Dr. Side **ORDER #4607L**

Pass. Side **ORDER #4607R**

**\$34<sup>00</sup>** ea.



*Ron  
Indiana*

# SEDAN, COUPE, STATION WAGON, DELIVERY

## 1949-52 Cars Vent Window and Door Parts

**1**

**VENT WINDOW WEATHERSTRIP**

4-piece set for both front doors. Includes correct vertical seals.



ORDER #5011

**\$75<sup>00</sup>** set

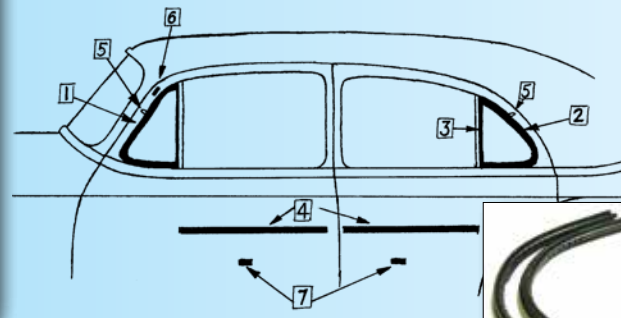

**2**

**REAR DOOR VENT WINDOW WEATHERSTRIP**

(4 door Deluxe Sedans)  
(Pair) Both rear vent windows. Order vertical seals separately.

**STYLELINE DELUXE**  
ORDER #5012  
**\$146** pr.

**FLEETLINE DELUXE**  
ORDER #5013  
**\$153** pr.



**3**

**GLUE-ON VERTICAL SEAL**

The quick fix for noisy vent windows. Front or rear.



ORDER #1010  
**\$11** pr.

**4**

**GLASS SETTING CHANNEL RUBBER**

Rubber to set side window glass into glass channels. 4 pc. set. Does all 4 side windows.



ORDER #1015  
**\$27** 4-pc. set

**2A**

**REAR DOOR VENT WINDOW GASKETS**

(4 DOOR SPECIAL STYLELINE SEDAN)  
Stationary vent window gaskets (pair)



ORDER #5014  
**\$125** pr.

**5**

**VENT WINDOW RIVET**

Special shouldered rivet that vent window frame pivots on when opening or closing vent window. These need to be replaced when replacing vent window weatherstrip.



SEDAN ONLY

ORDER #1069  
**\$5<sup>00</sup>** pr.

**6**

**SEDAN UPPER DOOR ACCESS PLUG**

Plugs found on leading top edge of doors.



ORDER #601-10  
**\$4<sup>00</sup>** pr.

**7**

**SEDAN LOWER WINDOW STOP IN DOOR**

Prevents windows from being lowered too far. Sold in pairs. Requires 2 per car.



ORDER #1014  
**\$8<sup>00</sup>** pr.

**WINDOW REGULATOR GROMMETS**

(Set of 4)

ORDER #1066  
**\$10<sup>00</sup>** set



**DOOR JAMB DOME LIGHT SWITCH GASKET**



ORDER #1006  
**\$6<sup>00</sup>** pr.

**WINDOW REGULATOR ROLLER KIT**

Fits all models.



ORDER #1074  
**\$5<sup>00</sup>** ea.

**VENT WINDOW GLASS SETTING RUBBER**

Correct rubber to set vent window glass in frame.



ORDER #1065  
**\$11<sup>00</sup>** pr.



# SEDAN VENT WINDOW AND DOOR PARTS

## 1953-54 Cars

### VENT WINDOW GLASS SETTING RUBBER

Seal that is used to install glass in vent window frame.

ORDER #1065

**\$10** pr.



2



### GLUE-ON VERTICAL SEAL

The quick fix for noisy vent windows.

ORDER #1010

**\$11<sup>00</sup>** pr.

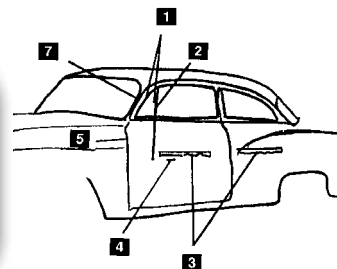

1

### VENT WINDOW WEATHERSTRIP

Includes correct vertical seal with wire core.

ORDER #1011

**\$75<sup>00</sup>** 4-pc. set



3

### GLASS SETTING CHANNEL RUBBER

Put this in the track that you set glass in.

ORDER #1015

**\$27<sup>00</sup>** 4-pc. set

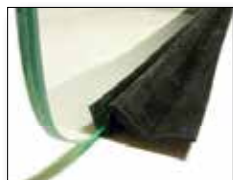

5

### DOOR JAMB DOME LIGHT SWITCH GASKET

ORDER #1006

**\$6<sup>00</sup>** pr.



4

### LOWER WINDOW STOP IN DOOR

Keeps window from going down too far. Requires 2 per car.

ORDER #1014

**\$8<sup>00</sup>** pr.



7

### SEDAN UPPER DOOR ACCESS PLUG

Provides access to vent windows.

ORDER #601-10

**\$5** pr.



### VENT WINDOW RIVET

For all sedans. When replating frames this rivet puts frame and glass back together. Required to replace weatherstrip.

ORDER #1069

**\$5<sup>00</sup>** pr.



Russ  
Easton, Pennsylvania

### WINDOW REGULATOR ROLLER KIT

Fits all models.



ORDER #1074

**\$5<sup>00</sup>** ea.

# BELAIR HARDTOP & CONVERTIBLE

1949-52 Cars

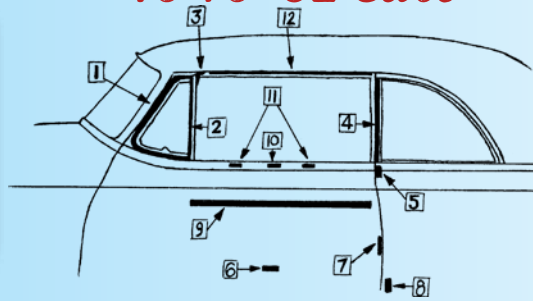

**1 VENT WINDOW WEATHERSTRIP**  
 Exact reproduction weatherstrip will do both sides. Purchase vertical seals separately.  
 ORDER #5015  
**\$150** set

**2 GLUE-ON VENT WINDOW VERTICAL SEALS**  
 (pair)  
 ORDER #1010  
**\$11.00** pr.

**4 QUARTER WINDOW SEALS**  
 ORDER #1009  
**\$16.00** pr.

**2A WIRE CORE VENT WINDOW VERTICAL SEALS**  
 (pair)  
 Like original. With retaining tabs.  
 ORDER #5016  
**\$40.00** pr.

**3 SIDE WINDOW BUMPER**  
 Found on back side of vent window assembly at top.  
 ORDER #1012  
**\$27.00** pr.

**5 QUARTER WINDOW STOP (pair)**  
 Bumper for quarter window on body lock pillar.  
 ORDER #5017  
**\$50** pr.

**6 LOWER WINDOW STOP IN DOOR (pair)**  
 For convertible and hardtops. Different than Sedans.  
 ORDER #1007  
**\$9.00** pr.

**7 DOOR GUIDE STOPS (pair)**  
 Found on back edge of door, guides door when shutting.  
 ORDER #5018  
**\$70.00** pr.

**8 LOWER REAR QUARTER WINDOW STOP (pair)**  
 ORDER #1047  
**\$6** pr.

**WINDOW REGULATOR ROLLER KIT**  
 Fits all models.  
 ORDER #1074  
**\$5.00** ea.

**9 GLASS SETTING CHANNEL RUBBER**  
 (4 pcs.)  
 Rubber used to set front door glass into glass tracks.  
 ORDER #1015  
**\$27** set

**WINDOW FRAME GLASS SETTING CHANNEL**  
 Rubber channel to install glass in chrome window frames. Will do all 4 windows.  
 ORDER #1072  
**\$26** set

**VENT WINDOW GLASS SETTING RUBBER**  
 Correct rubber to install vent window glass into frame.  
 ORDER #1065  
**\$10.00** pr.

**10 DOOR GLASS ANTI RATTLE ROLLERS**  
 (Guides)  
 Set of 4. Rubber rollers only.  
 ORDER #1008  
**\$9.00** set

**11 UPPER DOOR GLASS ADJUSTABLE STOPS**  
 Complete assemblies with rubber caps. (Sold in pairs). 2 prs. required per car.  
 ORDER #1061  
**\$38** pr.

**11A RUBBER STOPS**  
 (Set of 4) Rubber caps for adjustable door stops only.  
 ORDER #1060  
**\$10** set

**12 1952 FLIPPER BAR SEAL RUBBER (pair)**  
 For 1952 BelAir Hardtop  
 ORDER #1032  
**\$16.00**

**DOOR JAMB DOME LIGHT SWITCH GASKETS (pair)**  
 ORDER #1006  
**\$6.00** pr.

**WINDOW REGULATOR GROMMETS (Set of 4)**  
 ORDER #1066  
**\$10.00** set



# HARDTOP/CONVERTIBLE VENT WINDOW & DOOR PARTS

## 1 VENT WINDOW WEATHERSTRIP

One piece molded rubber.  
Cut to install. Includes instructions.

ORDER #1011HC  
**\$110<sup>00</sup>** pr.

Order vertical seals separately.



## 1953-54 Cars

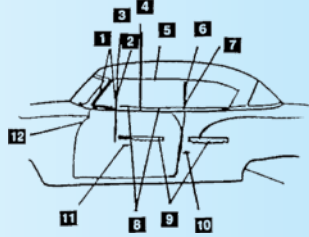

## VENT WINDOW WEATHERSTRIP

Molded rubber with metal core like the original.  
Includes installation screws.

ORDER #1075

**\$140**

Order vertical seals separately.



## 2 GLUE-ON VENT WINDOW VERTICAL SEAL

(Pair)

ORDER #1010 **\$11<sup>00</sup>**



## 2A WIRE CORE VENT WINDOW VERTICAL SEAL

Like original needed to complete new vent window weatherstrip kit.

ORDER #1035HC **\$20<sup>00</sup>** pr.



## 6 QUARTER WINDOW SEAL

ORDER #1009

**\$16<sup>00</sup>** pr.



## 3 SIDE WINDOW BUMPER

ORDER #1012

**\$25** pr.



## 4 DOOR GLASS ROLLERS

(4 per set)

ORDER #1008

**\$9** set



## 5 FLIPPER BAR SEAL

ORDER #1032

**\$19<sup>00</sup>** pr.



## 7 QUARTER WINDOW STOP

ORDER #1046

**\$15<sup>00</sup>** pr.



## 8 UPPER DOOR WINDOW STOP

(Set of 4) Rubber Caps only

ORDER #1060

**\$11<sup>00</sup>**



## 11 HARDTOP/CONVERTIBLE LOWER WINDOW STOP IN DOOR (Pair)

ORDER #1007

**\$9<sup>00</sup>**



## 9 GLASS SETTING CHANNEL RUBBER

(4 pcs.)

ORDER #1015

**\$27**



## 10 LOWER REAR QUARTER WINDOW STOP (Pair)

ORDER #1047

**\$6<sup>00</sup>**



## UPPER DOOR GLASS ADJUSTABLE STOPS

With rubber caps.

ORDER #1061

**\$35** pr.



## 12 DOOR JAMB DOME LIGHT SWITCH GASKET (Pair)

ORDER #1006

**\$6<sup>00</sup>**



## VENT WINDOW GLASS SETTING RUBBER

Used to set glass in vent window frames

ORDER #1065

**\$9** pr.



## 1953/54 HARDTOP/CONVERTIBLE WINDOW FRAME GLASS SETTING CHANNEL

Rubber channel to hold side window glass in frames when replacing glass or rechroming frames.

ORDER #1072

**\$25<sup>00</sup>** set



## WINDOW REGULATOR ROLLER KIT

Fits all models.

ORDER #1074

**\$5<sup>00</sup>** ea.



# BELAIR HARDTOP ROOF RAIL WEATHERSTRIP

## 1950 (1st Type) EARLY

Rubber for above front and quarter windows.

Order #5019 **\$310<sup>00</sup>** set

## 1950 (2nd Type) LATE, 1951 ALL

Front doors only. Rubber stops at rear of door.

For cars with flipper bars. **\$270<sup>00</sup>** set

Order #5020

## 1952 ALL

Order #5021 **\$160<sup>00</sup>** set

4 Piece Set, Windshield Posts and Roof rail at Hinge Pillars



#5019

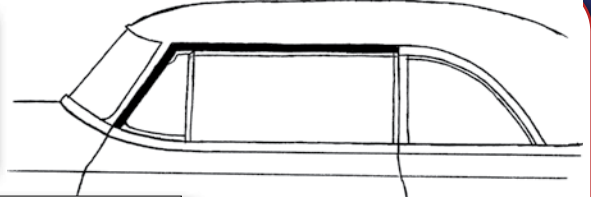

#5020



#5021

# OUTSIDE SUNVISORS

## 1949-52 METAL OUTSIDE SUNVISOR



Metal outside sunvisor that fits Styleline or Fleetline Sedans.

ORDER #8106

**\$495**

## 1953-54 HARDTOP OUTSIDE SUNVISOR

Metal sunvisor with stainless end brackets. Also includes center bracket, gasket & instructions.



ORDER #8150-1 **\$600** \*Oversize Shipping

## 1950-52 CHEV HARDTOP OUTSIDE SUNVISOR

Great quality, fits nice too!  
Paint to match your car.



ORDER #8106-1 **\$600**

*New*

## 1953-54 SEDAN OUTSIDE SUNVISOR

Metal sunvisor with stainless end brackets. Also includes center bracket, gasket and installation instructions.



ORDER #8150 **\$495**  
\*Oversize Shipping

*New*

## SEDAN SUNVISOR END BRACKETS

Fits 1953-54 cars only.

ORDER #8150-3 **\$90** pr.



## 1953-54 OUTSIDE SUNVISOR CENTER BRACKET

Old sunvisor bracket pitted or missing? Replace it with a new one. Gasket included.



ORDER #1704 **\$32<sup>00</sup>**



## SUNVISOR BRACKET GASKET ONLY

ORDER #1704G **\$6**



# 1949-52 CONVERTIBLE TOP SEALS

## 1 CONVERTIBLE HEADER SEAL (Set) Includes header and top of windshield

Order #5022 **\$220<sup>00</sup>** set



#5022

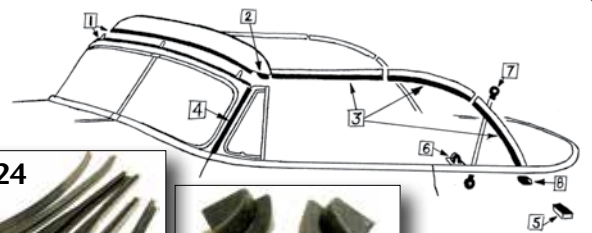

## 2 CONVERTIBLE TOP CORNERS

Order #5023 **\$63<sup>00</sup>** pr.



#5024

## 3 ROOF RAIL WEATHERSTRIP

(6 piece set) Molded to original shape, can be covered with bowdrill cloth.

Order #5024 **\$240<sup>00</sup>** set



#5025

## BOW DRILL CLOTH

(Not shown in diagram.) Covers roof rail rubber. 5 ft. pc. - 5" wide. Need 2 per car.

BLACK ORDER #747B **\$38<sup>00</sup>**  
TAN ORDER #747T **\$38<sup>00</sup>**



#5023

## 4 HINGE PILLAR WEATHERSTRIP

(Pair) (Windshield posts)

Order #5025 **\$99<sup>00</sup>** pr.



## 5 REAR BOW BUMPERS

ORDER #5026 **\$70<sup>00</sup>**

## 6 RUBBER CUSHIONS

Rubber only. Cement to metal core.

ORDER #5027

**\$55<sup>00</sup>** Pr.



## 7 1950 CONVERTIBLE BUMPER CAP

(Set of 4)

ORDER #5028 **\$90** Set



## 8 1950-52 PAD, TOP REST

(Pair)

ORDER #5029 **\$83** Pr.



# 1953-54 CONVERTIBLE TOP SEALS

## 1 ROOF RAIL WEATHERSTRIP

Molded 6 pc. set. Fits original retainers.

ORDER #745

**\$195<sup>00</sup>** set



MOLDED SHAPE

## 2 CONVERTIBLE TOP CORNERS

Joins side roof rail to windshield header (pair)

ORDER #746 **\$80<sup>00</sup>**

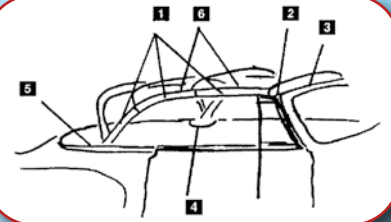

## 3 TOP HEADER SEAL

Seals top to windshield

ORDER #755 **\$50<sup>00</sup>**



## 4 RUBBER SEAL

ORDER #758 **\$7<sup>00</sup>** pr.



## 5 CONVERTIBLE FOLDING TOP STOPS

ORDER #756 **\$9** pr



## 6 CONVERTIBLE BOW STOPS

(Set of 4)

ORDER #757

**\$20<sup>00</sup>** set



## 7 RUBBER STRIP

Used to make finished edge on front of top header - 5' pc.

ORDER #766

**\$8<sup>00</sup>**



# WIPER

## 6V ELECTRIC WIPER MOTOR



Wipers work better and more consistently for better vision.

1949-52  
ORDER #6432-6V  
1953-54  
ORDER #2432-6V  
**\$309<sup>00</sup>**

## 12 VOLT ELECTRIC WIPER MOTOR

Converted to 12 volts? This 12 volt electric wiper motor might be the answer to poor wiper performance. Bolts in stock location with no modifications necessary.

Complete with wiper switch and installation instructions. (2 speed 12 volt motor).



1949-52 ORDER #6432  
1953-54 ORDER #2432

**\$259<sup>00</sup>**

## WIPER ARMS - SEDAN



These wiper arms are perfect replacements for broken or badly pitted arms. They are slightly longer than originals, but work great.

(Will not fit BelAir Hardtop and Convertible.)

PASSENGER SIDE      DRIVER SIDE  
ORDER #1138R      ORDER #1138L  
**\$18<sup>00</sup>**      **\$18<sup>00</sup>**

## WINDSHIELD WASHER NOZZLES



ORDER #1145

**\$8<sup>00</sup>** pr.

## WIPER BLADES

New wiper blades will greatly improve your vision when raining.  
Exact replacements will snap right on to original wiper arms.



ORDER #1112  
**\$30<sup>00</sup>** pr.

## WINDSHIELD WIPER MOTOR VACUUM LINE

Correct length and diameter vacuum hose.  
Runs from intake manifold to wiper motor.



1949-52 ORDER #5140  
1953-54 ORDER #1140  
**\$10<sup>00</sup>** ea.

## 1953-54 AUXILIARY WIPER DRIVE SEAL

ORDER #611  
**\$10<sup>00</sup>** pr.



## 1949-52 WINDSHIELD WIPER TRANSMISSION GASKETS

(Pair)



ORDER #4610  
**\$8<sup>00</sup>** pr.

## 1953-54 WIPER TRANSMISSION GASKET

ORDER #610  
**\$8<sup>00</sup>** pr.



## 1949-52 WIPER TRANSMISSION CLIP AND SPRING

ORDER #4614 **\$6<sup>00</sup>**

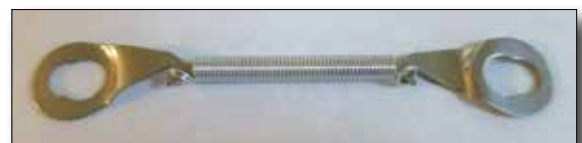



# GAS TANKS - SENDING UNITS

## STEEL GAS TANK

Just like original. Use your sending unit and gas line.

1949-52 ORDER #7103

*Only*

1953-54 ORDER #7104

**\$280<sup>00</sup>**



\*1949-52  
Tank pictured.

## GAS TANK STRAPS

For 1949-54 cars



Pre-Bent Stainless Straps

ORDER #1339

**\$27** pr.

Pre-Bent Steel  
Coated Straps

ORDER #1339B

**\$22** pr.

Universal Coated  
Steel Straps

ORDER #1339C

**\$18** pr.

Universal Stainless Straps

ORDER #1339D

**\$22** pr.



## GAS TANK SENDING UNIT

**Brand new** replacement gas tank sending unit includes gasket and screws.  
Low cost alternative to AC Delco unit without sacrificing quality. FOR 6 OR 12V CARS



1949-52 SEDAN/HT/CONV.  
ORDER #5330

1953-54 SEDAN/HT/CONV.  
ORDER #1330

**\$65<sup>00</sup>**

## ACCESSORY FUEL FILTER

ORDER  
#1361

**\$29**



## 1953-54 REPLACEMENT GAS CAP



No, it doesn't look  
like the original,  
but it works just  
like it.

ORDER #816  
**\$10<sup>00</sup>**

## GAS TANK STRAP LINER



Gasket goes  
between gas  
tank  
and straps.

ORDER  
#1348

**\$10** pr.

## GAS TANK FLOAT

**Replacement float**  
for your worn one.

ORDER  
#1359

**\$11**



## 1949-52 FUEL TANK CONNECTOR HOSE

Oil and gas resistant.  
Connect neck to tank.

ORDER  
#5337

**\$14** pr.



## SENDING UNIT GASKET AND SCREWS



ORDER  
#1352

**\$5**  
Set

# GAS TANKS

## No Rust - No Problems

### POLY GAS TANK

Molded to original dimensions with ease of installation in mind. Use your gas line. Complete with hardware and installation instructions. The poly gas tank is made in the USA, and was designed exclusively for 1949-54 Chevrolets with the latest technology. With safety and durability in mind the poly tank will never rust and is made to last. Most new cars use a poly tank for this exact reason. The alcohol in gasoline will separate and sit at the bottom of the tank causing rust issues in a steel tank. With your safety and restoration in mind the poly tank is recommended for hassle free maintenance, and to keep your old Chevy on the road for years to come. **Includes new sending unit.**

**Best Value** 1949-52 ORDER #1336  
1953-54 ORDER #5336



(1949-52 Tank and Hardware Pictured)

## GAS LINES

- A SEDAN GAS LINE** ..... \*Oversize Shipping ..... ORDER #1398 **\$89<sup>00</sup>**
- B HARDTOP GAS LINE** ..... ORDER #1371 **\$89<sup>00</sup>**
- C CONVERTIBLE GAS LINE** (2 PC.) .. ORDER #1370 **\$94<sup>00</sup>**
- SEDAN DELIVERY/  
STATION WAGON GAS LINE** ..... ORDER #1373 **\$89<sup>00</sup>**

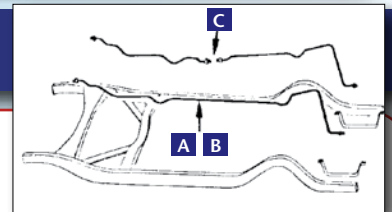

### GAS LINE FRAME CLIP



Used to hold fuel line to frame of car.  
**(Requires 5 per car.)**

ORDER #1418  
**\$5<sup>00</sup>** ea.

## SEDAN DELIVERY/STATION WAGON TANKS

### 1949-54 STATION WAGON/SEDAN DELIVERY STEEL GAS TANK

Just like the original.

ORDER #7104SWD **\$350**



### STATION WAGON SEDAN DELIVERY SENDING UNIT

ORDER #1331 **\$50**



### SEDAN DELIVERY/STATION WAGON PRE-BENT GAS TANK STRAPS

ORDER #1339A **\$24** pr.



### LOCKING GAS CAP 1953-54 WAGON/ SEDAN DELIVERY ALL 1949-52 MODELS



ORDER #4812

**\$12**

### NON-LOCKING GAS CAP

Fits all 1949-52 models and 1953-54 Sedan Delivery/Station Wagons.



ORDER #4812-1  
**\$12<sup>00</sup>**

### SEDAN DELIVERY STATION WAGON GAS TANK NECK GROMMET

ORDER #829

**\$58**





# GAS DOOR GUARDS & GROMMETS

## 1953-54 STAINLESS GAS DOOR GUARD

Fits great, excellent quality, looks good too!



ORDER #509

**\$26**

## 1949-50 ACCESSORY GAS DOOR GUARD



Good quality, looks good!

ORDER #4515

**\$26<sup>00</sup>**

## 1951-52 ACCESSORY GAS DOOR GUARD



Excellent quality that looks & fits great.

ORDER #4515-1

**\$26<sup>00</sup>**

# ACCELERATOR PEDALS AND SEALS

## FUEL PUMPS, FUEL GAUGES & LINES

### GLASS BOWL FUEL PUMP

No picture available.  
Fits 1949-54 Chevies. Fits 1949-50 to change to 1951-54 move over 1 hole

**CALL FOR PRICE**

AVAILABLE APPROX. APRIL 2022

*New*

### 1949-54 ACCELERATOR PEDAL

Excellent reproduction with metal tab for attaching.

ORDER #737

**\$25**



### 1949-54 ACCESSORY ACCELERATOR PEDAL COVER

Protects carpet from heel wear.

ORDER #738

**\$30**



### GAS DOOR GROMMET

ORDER #601-6

**\$8 pr.**



Includes Screws

### 1949-51 REPLACEMENT FUEL PUMP

Just like original without glass bowl.

Fits 1952 std. trans. also.

ORDER #5391

**\$75**



### 1952-54 REPLACEMENT FUEL PUMP

Fits 1952 auto. trans.  
All 1953-54 cars.  
Replacement fuel pump with correct inlet and outlet.

ORDER #1329

**\$75**



### 1952-54 ACCESSORY FUEL PUMP VACUUM LINES

Vacuum lines and fittings for use with the accessory fuel pump. Reproduced from "originals," with correct bends. Includes rubber vacuum hose to connect to wiper motor. With instructions.

ORDER #1369

**\$54**



### FUEL PUMP TO ENGINE BLOCK GASKET

Replaces leaking or old gasket.

ORDER #1393

**\$6**



### 1949-52 FUEL GAUGES

*New*

Solve your gauge problem with this very nice reproduction

1949-50 6V ORDER #1355

1949-50 12V ORDER #1355-A

1951-52 6V ORDER #1355-B

1951-52 12V ORDER #1355-C



Replaces GM# 1617341

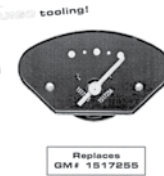

Replaces GM# 1617255

**\$78 Ea.**

# CARBURETOR KITS, GASKETS

## CARTER W-1 REBUILD KIT MANUAL CHOKE.



Contains parts to rebuild carb.

ORDER #5304  
**\$53<sup>00</sup>**

## CARTER Y-F REBUILD KIT MANUAL CHOKE.



ORDER #5304-1

**\$45<sup>00</sup>**

## ROCHESTER CARB KIT AUTO & MANUAL CHOKE REBUILD KIT FOR YOUR CARBURETOR.



ORDER #1304

**\$27<sup>00</sup>**

## ROCHESTER CARBURETOR FLOAT

Bad or bent float your problem? Replace it with a new one.

ORDER #1351  
**\$25<sup>00</sup>**



## CARBURETOR GASKET

Fits above insulator plate to bottom of carburetor.

235 ENG. ORDER #1397  
216 ENG. ORDER #1397-1

**\$6<sup>00</sup>** ea.

# CARBURETOR INSULATION PLATES

## INSULATOR PLATE FOR CARTER YF OR WI CARB



ORDER #1349-1



216 Side Pan

**\$15<sup>00</sup>**

## INSULATOR PLATE FOR ROCHESTER AUTO/MANUAL CHOKE CARB



ORDER #1349



235 Side Pan

**\$15<sup>00</sup>**

# CARBURETOR/FUEL PUMP LINES

## 1952-54 ROCHESTER CARB WITH AUTO CHOKE/SIDE MOTOR MOUNTS

### ORIGINAL FUEL LINE



Line goes from fuel pump to carburetor.

ORDER #1399  
**\$35<sup>00</sup>**

### ORIGINAL ACCESSORY FUEL LINE



Line goes from fuel pump to fuel filter to carburetor.

LINE ONLY  
ORDER #1394  
**\$35<sup>00</sup>**



### ORIGINAL VACUUM LINE

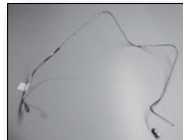

Line goes from distributor to carburetor.

ORDER #1384  
**\$35<sup>00</sup>**

**NOTE:** Fuel lines, accessory fuel lines, vacuum lines available for Carter Carbs also.

Model W1 and YF.

Call for more information.



# 1949-52 ENGINE GASKETS

## VALVE COVER GASKET

FOR 216/235 ENGINE  
ORDER #1346

**\$24<sup>00</sup>**

## SIDE PAN GASKET

FOR 216 ENGINE  
ORDER #5345

**\$24<sup>00</sup>**

FOR 235 ENGINE  
ORDER #1345

**\$22<sup>00</sup>**

## EXHAUST MANIFOLD GASKET SET

FOR 216 ENGINE  
ORDER #5395

**\$28<sup>00</sup>**

FOR 235 ENGINE  
ORDER #1395

**\$24<sup>00</sup>**



## OIL PAN GASKET SET

FOR 216/235 ENGINE  
ORDER #1340

**\$24<sup>00</sup>**

## HEAD GASKET SET

Includes gaskets for valve cover, side pan, exhaust manifold, water pump, thermostat.

FOR 216 ENGINE  
ORDER #5341

**\$75<sup>00</sup>**

FOR 235 ENGINE (1950-52)  
ORDER #5341-1

**\$68<sup>00</sup>**

## REAR MAIN SEAL

CORD SEAL  
ORDER #1343

**\$28<sup>00</sup>**



## SILICONE GASKET SEALER

ORDER #1392

**\$15<sup>00</sup>** ea.



## INTAKE TO EXHAUST MANIFOLD GASKET



For 235 Motor  
ORDER #1337

**\$6<sup>00</sup>**

# MOTOR MOUNTS

## 1949-51 FRONT ENGINE MOUNT

For cars with standard transmission.

ORDER #5105

**\$70<sup>00</sup>** pr.



## 1949-51 SIDE ENGINE MOUNT

For cars with Powerglide or standard transmission.



ORDER #5105-1

**\$45<sup>00</sup>** pr.

## 1952-54 MOTOR MOUNTS

Replace squashed and worn mounts with just like original new mounts.



ORDER #1105

**\$60** set of 4

# 1953-54 ENGINE GASKETS

## SILICONE GASKET SEALER



ORDER #1392  
**\$15** ea.

## INTAKE MANIFOLD SLEEVES

216 ENGINE  
 ORDER #1368A  
 235 ENGINE  
 ORDER #1368

**ONLY**  
**\$20** SET OF 3



## HEAD GASKET SET

FOR 235 ENGINE  
 Contains thermostat housing seal, side pan gasket, head gasket, intake to exhaust gaskets, valve cover gasket, valve stem seal.

ORDER #1341 ..... **\$78<sup>00</sup>** set

## OIL PAN GASKET SET

FOR 235 ENGINE  
 ORDER #1340 ..... **\$24<sup>00</sup>** ea.

## SIDE PAN GASKET

FOR 235 ENGINE  
 ORDER #1345 ..... **\$20<sup>00</sup>** ea.

## VALVE COVER GASKET

FOR 1953 ENGINE  
 ORDER #1346 ..... **\$20<sup>00</sup>** ea.

FOR 1954 ENGINE  
 ORDER #1347 ..... **\$16<sup>00</sup>** ea.

## EXHAUST MANIFOLD GASKET SET

FOR 235 ENGINE  
 ORDER #1395 ..... **\$26<sup>00</sup>**



*Dedicated to the  
 Preservation, Pleasure and Pride  
 in 1949-54 Chevrolets*

## IDENTIFY YOUR ENGINE

Ever wanted to know if the motor in your car is the original? ...  
 Or just wanted to know how to identify when it was made?

Chevrolet cast the date of manufacture just above the starter, right on the engine block. (This is not the stamped numbers by the distributor, which is the engine serial number.) The cast "boss" is halfway between the pan flange and the pushrod cover, and consists of an initial (A-L = January-December) followed by three or four digits. Example: B154 equals - February 15, 1954.

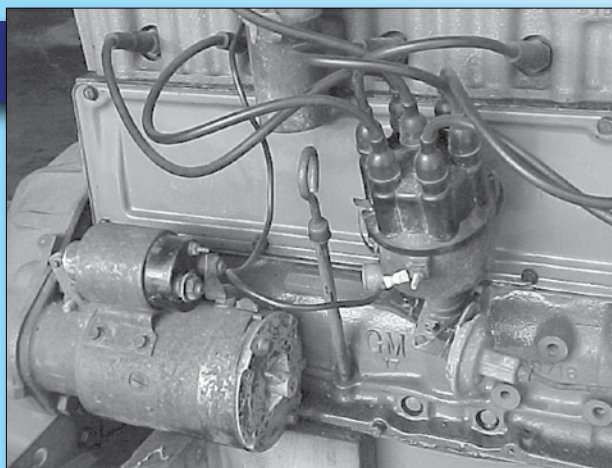



# OIL FILTER/LINES/CAP

## 1949-54 REPLACEMENT OIL FILTER LINES



Correct length and look. Sold in pairs (includes instructions).

ORDER #1362-1 **\$79** set

## 1949-54 REPLACEMENT OIL FILTER LINES



Correct length and look. Sold in pairs (includes instructions).

**\*Includes fitting for sending outlet.**

ORDER #1362 **\$89** set

## 1949-54 OIL FILTER

Fits all models.  
Comes with gasket.



ORDER #1312

**\$35** ea.

## 1949-54 OIL FILTER GASKET



ORDER #1312-1

**\$5** ea.

## 1949-54 OIL CAP

ORDER #1381

**\$14** ea.



## 1949-54 COPPER OIL LINE

Goes from oil gauge to the outlet on the side of engine.

**Includes fittings.**

ORDER #1320

**\$31** ea.

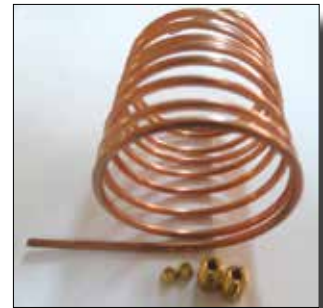

## VALVE COVER NUT CHROME KIT



ORDER #1911

**\$6<sup>00</sup>**

## VALVE COVER GROMMETS

These grommets are used on top of valve cover where bolts go thru.



ORDER #1913

**\$8<sup>00</sup>** pr.

*Note*  
Engine paint can be found on page 27 in this catalog

# OIL FILTER/LINES/CAP



## ORANGE

For the top of the oil filter canister.



ORDER #1382

**\$14** can

## CHEVY BLUE

For the top of the oil filter canister.



ORDER #1313

**\$14** can

## HOW TO START AN ALASKA CAR

1. CHEECHAKO: Owner, fresh from the states, dashes out at 7:45 a.m. full of optimism and energy, chops off enough ice from the windshield to form a peephole to be used as a sort of sight over the radiator cap (theory being that a line from the steering wheel over the radiator cap will guide one down the street), injects a pint of ether into the carburetor, pours a pint of alcohol into the tank (takes a snort himself), steps on the starter which is connected to four truck batteries.

RESULTS: Arrives at work 3 hours late.

2. EXPERIMENTAL: Owner becoming desperate having tried everything but arising early, he is now a gadgateer, installs crank case heater, head-bolt heater, carburetor heater, de-icers and fuel pump heater as well as dip stick.

3. SOURDOUGH: The accepted method tested by time.

1. Arises at 3:00 a.m. (reluctantly)
2. Digs car from ice and snow.
3. Kicks car soundly 3 or 4 times to establish respect for

authority. Appears disinterested in whether or not car starts, lights pipe or cigar, using gadget from the bonfire previously lighted to warm hands, hovers in the vicinity, musing aloud about the beauty of the scenery.

4. Raises head, shakes head disapprovingly, mentions several reasons why the purchase of a new car is indicated.

5. Kicks car soundly four or more times.

6. Returns to house with feigned intention of remaining.

7. Drinks a cup of coffee, being sure car can see him through the window.

8. Nonchalantly saunters back and kicks car four more times.

9. Pries open door with crowbar and removes icicles from dash, steering wheel and seat.

10. Unobtrusively pulls the choke out three or four feet.

11. Turns ignition key on with pair of pliers....NOW -

12. (HURRIEDLY) jumping into car, he slams foot on starter, kicks car soundly with other foot three or four times, curses loudly, beats dash (preferably with hammer).

RESULTS: Arrives at work only one hour late.



# 1949-54 ENGINE ELECTRICAL

## AC SPARK PLUGS

RESISTER PLUGS Set of 6



ORDER #1302R

**\$29** set

## PLUG WIRES

ORDER #1301 **\$60** set



## TUNE UP KIT

Includes rotor, distributor cap, points, condensor.

1949-52 ORDER #5346

**\$50<sup>00</sup>**

1953-54

ORDER #1307

**\$48<sup>00</sup>**



## VOLTAGE REGULATOR

ORDER #1321

**\$145<sup>00</sup>**



## 6V COIL

ORDER #1303

**\$59<sup>00</sup>**



## 1949-52 STARTER BUTTON SWITCH

Has chrome button with stainless retainer.

ORDER #4604

**\$52<sup>00</sup>**



## STARTER REBUILD KIT

ORDER #2210

**\$11<sup>00</sup>**



## STARTER SOLENOID BOOT

Rubber boot to keep dirt and debris out of critical solenoid plunger area.



ORDER #1305

**\$9<sup>00</sup>**

## STARTER SOLENOID

ORDER #1316

**\$92<sup>00</sup>**



## STARTER MOTOR BRUSH BAND

Improve appearance of starter motor and keep dirt from affecting starter performance.

ORDER #1310

**\$6<sup>00</sup>**



## GENERATOR REBUILD KIT

ORDER #2211

**\$11<sup>00</sup>**



## CAL CUSTOM AIR CLEANER FILTER

ORDER #2109

**\$9<sup>00</sup>** ea.



## CAL CUSTOM AIR CLEANER

Perfect for that dual carb setup. Correct size for 1953-54 carb.



ORDER #2110

**\$18<sup>00</sup>** ea.

## ELECTRONIC IGNITION

Never use points again.

6V 1949-54 Cars  
ORDER #1389

**\$149<sup>00</sup>**

12V 1949-54 Cars  
ORDER #1389-1

**\$135<sup>00</sup>**

12V 1949 to 1954 Cars  
Hi Performance Flame Throwing Coil (Hotter Spark)  
ORDER #1389-4

**\$60<sup>00</sup>**



## 1949-51 VACUUM ADVANCE

ORDER #5338

**\$42**

## 1952-54 VACUUM ADVANCE

ORDER #1338

**\$46** ea.



# TRANSMISSION, CLUTCH & SPEEDOMETER

## 1949-54 THROWOUT BEARING



ORDER #1375

**\$42<sup>00</sup>**

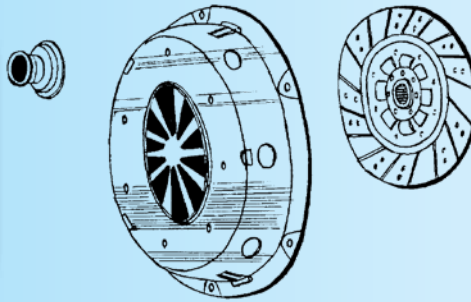

## 1949-54 SPEEDOMETER CABLE

Has spiral metal casing like original. Will fit both standard or powerglide transmissions.



ORDER #1139  
**\$28<sup>00</sup>**

## 1949-54 SHIFT BOX SHAFT RUBBER BOOT



(Std. Transmission)

ORDER #1136

**\$8<sup>00</sup>**

## 1949-54 SHIFT LEVER BUSHING



ORDER #1135

**\$8<sup>00</sup>** pr.

## POWERGLIDE TRANSMISSION COOLER LINE SET



Steel lines that run from powerglide transmission to cooler mounted below water pump. Correct bends and fittings.

1950-51 ORDER #5453  
1952-54 ORDER #1453

**\$60<sup>00</sup>** pr.

## 1950-54 POWERGLIDE TRANSMISSION VACUUM LINE

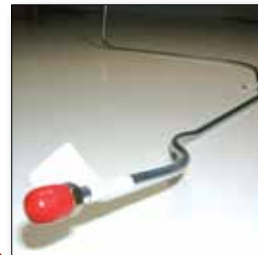

Steel vacuum line that runs from intake manifold to transmission. Proper bends ensure correct routing of line between oil pan and transmission.

ORDER #1452

**\$25<sup>00</sup>**

## UNIVERSAL JOINT GASKET SET

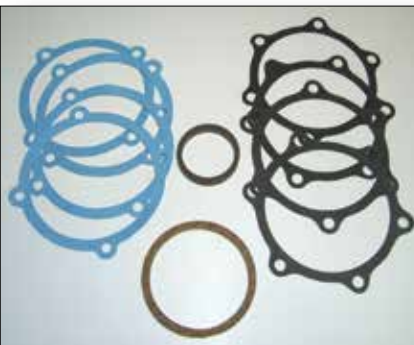

Includes gaskets for both standard and automatic transmissions.

1949-54  
ORDER #1363

**\$20<sup>00</sup>**

## 1949-54 PILOT BUSHING

ORDER #1325

**\$18<sup>00</sup>**



## UNIVERSAL JOINT BOLT AND CLIP SET



1949-54  
ORDER #1912

**\$17<sup>00</sup>**



# TRANSMISSION, CLUTCH & SPEEDOMETER

## 3-SPEED FLOOR SHIFT KIT

Designed to fit your 1949-54 exclusively – not a universal fit. Shifter does not interfere with the seat and shift pattern fits the car perfectly. Preassembled, easy to install and instructions are included.

1949-52 ORDER # 7105-1

1953-54 ORDER # 7105

*\* Not for convertibles*

**\$269<sup>00</sup>**



## 1952-54 TRANSMISSION MOUNT (REAR MOTOR MOUNT)

This usually needs replacement, especially on cars with powerglide.

**POWERGLIDE ORDER #1108**

**STANDARD TRANSMISSION ORDER #1108S**

**\$28<sup>00</sup>**



## 1949-54 SHIFT ROD GROMMET

(with metal lining)

ORDER #1468

**\$4<sup>00</sup>** ea.



## DICE SHIFT KNOB

About 2" square with rounded corners.

Comes with size adaptors & wrench.

**RED ORDER #2139R**

**BLUE ORDER #2139BU**

**WHITE ORDER #2139W**

**BLACK ORDER #2139BK**

**\$13<sup>00</sup>**



## SKULL SHIFT KNOB

Heavy cast metal with chrome finish and red eyes. Has size adaptors and allen wrench.

ORDER #2138

**\$21<sup>00</sup>**

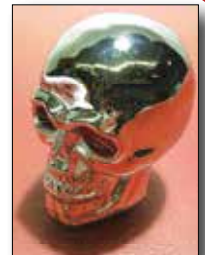

# WHEEL BEARINGS, SEALS, DIFFERENTIAL PARTS

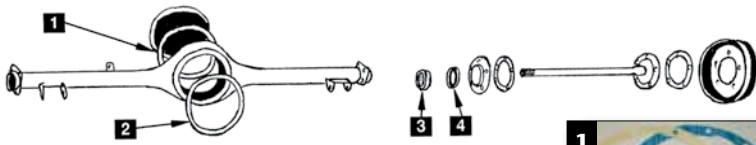

**1** REAR END COVER GASKET  
ORDER #1367

**\$14<sup>00</sup>** ea.

**2** DIFFERENTIAL GASKET  
ORDER #1366

**\$14<sup>00</sup>** ea.

**3** REAR WHEEL BEARING  
ORDER #1450

**\$75<sup>00</sup>** ea.

**4** REAR WHEEL (AXLE)  
GREASE SEAL  
ORDER #1451

**\$19<sup>00</sup>** ea.



**FRONT INNER  
WHEEL BEARING**  
ORDER #1410

**\$85<sup>00</sup>** ea.



**FRONT OUTER  
WHEEL BEARING**  
ORDER #1411

**\$64** ea.



**FRONT WHEEL  
BEARING GREASE SEAL**  
ORDER #1412

**\$18** ea.



## BATTERY

### 1949-54 BATTERY TRAY

Replace that old acid laden battery tray with this new one that's just like the original.

ORDER #1601

**\$45<sup>00</sup>**



### 1949-54 POSITIVE BATTERY CABLE

Special made plastic coated heavy gauge for 6V system.

ORDER #1608

**\$34**



### 1949-54 BATTERY HOLD DOWN BOLTS

ORDER #1603

**\$8<sup>00</sup>** pr.



### 1949-54 BATTERY TENDER

Lightweight and compact this keeps batteries constantly maintained and ready to go.

Great for those vehicles not constantly in use.



**6 VOLT**  
ORDER #2161

**12 VOLT**  
ORDER #2162

*Only* **\$70<sup>00</sup>**

### 1949-54 NEGATIVE BATTERY CABLE

ORDER #1609

**\$22<sup>00</sup>**



### BATTERY DISCONNECT SWITCH

Ideal for car storage disconnect and prevent battery drain. Remove contact knob and car cannot be started.

**TOP POST**  
ORDER #1612

**\$10<sup>00</sup>**

**SIDE POST**  
ORDER #1613

**\$15<sup>00</sup>**



### 1949-54 BATTERY RETAINER

Holds battery in its place.

ORDER #1602

**\$24<sup>00</sup>**





# 1949-52 BRAKES



**1949-50 FRONT  
BRAKE SHOES**  
ORDER #5401

**\$49<sup>00</sup>** set

**1949-50 REAR  
BRAKE SHOES**  
ORDER #5402

**\$49<sup>00</sup>** set

## BRAKE SHOES

Replace worn shoes with solid new shoes.

**1951-52 FRONT  
BRAKE SHOES**  
ORDER #1401

**\$43<sup>00</sup>** set

**1951-52 REAR  
BRAKE SHOES**  
ORDER #1402

**\$43<sup>00</sup>** set

## BRAKE SHOE HOLD DOWN SPRING KIT



Each kit will do 2 wheels.

Need 2 sets per car.

**1951-52 KIT**  
ORDER #1416

**\$15<sup>00</sup>** set



## 1951-52 BRAKE DRUM

New replacement.

Ready to install.

Fits all models.

ORDER #1427

**\$72<sup>00</sup>** ea.

## BRAKE ADJUSTING HOLE PLUG

2 sets needed for

1949-50 cars.

1 set needed for

1951-52 cars.



ORDER #1429

**\$5<sup>00</sup>** set of 4

## BRAKE SHOE RETURN SPRINGS



**1949-50.** Sold in pairs.  
Requires 4 springs per car.

ORDER #5403

**\$15<sup>00</sup>** pr.



**1951-52.**  
Sold in 4 per package.  
Requires 8 per car.

ORDER #1423

**\$14** set of 4

## BRAKE ADJUSTING SCREW SPRING

Requires 4 per car for 1951-52 models.

ORDER #1430

**\$9<sup>00</sup>** ea.



## BRAKE ADJUSTOR SCREW

1951-52 models. Sold separately. Requires 4 per car.

ORDER #1421

**\$15<sup>00</sup>** ea.



## BRAKE BLEEDER SCREW

Requires 4  
per car for  
1949-52  
models.



ORDER  
#1447

**\$3<sup>00</sup>** ea.

## BRAKE PEDAL RETURN SPRING

Connects to frame and  
brake pedal to return  
brake after use.

ORDER #1456 **\$11<sup>00</sup>**



## 1949-52 BRAKE AND CLUTCH PAD

Replace worn pads with  
new pads.  
Looks great!

ORDER #4702

**\$8<sup>00</sup>** ea.



## BRAKE LIGHT SWITCH

Exact reproduction.

**1949-50 SWITCH** **\$25<sup>00</sup>**  
ORDER #5332

**1951-52 SWITCH** **\$25<sup>00</sup>**  
ORDER #1332



## 1949-52 EMERGENCY BRAKE HANDLE

ORDER #5407  
**\$33<sup>00</sup>** ea.



# 1953-54 BRAKE SHOES / BRAKE DRUMS

## BRAKES SHOES

Even brake shoes can be a difficult item to find for a forty-year-old car, but we supply top quality shoes for your car.

**FRONT BRAKE SHOE SET** (Both wheels)  
ORDER #1401

**\$42<sup>00</sup>**

**REAR BRAKE SHOE SET** (Both wheels)  
ORDER #1402

**\$42<sup>00</sup>**



## BRAKE SHOE HOLD DOWN SPRING KIT

ORDER #1416

Sold by the set.  
Need 2 sets per car.



**\$15<sup>00</sup>** set

## BRAKE ADJUSTING SCREW SPRING

Requires 4 per car.

ORDER #1430 **\$9<sup>00</sup>** ea.



## BRAKE ADJUSTOR SCREW

Sold separately -  
Requires 4 per car.



ORDER #1421

**\$15<sup>00</sup>** ea.

## BRAKE ADJUSTING HOLE PLUG

Does all 4 wheels.



ORDER #1429

**\$6<sup>00</sup>** set of 4

## BRAKE SHOE RETURN SPRINGS

Sold in sets of 4.  
Need 8 springs per car.



ORDER #1423

**\$14<sup>00</sup>** set of 4

## 1953-54 POWER BRAKE PEDAL PAD

Exact reproduction. Excellent quality.



ORDER #727

**\$25**

## CLUTCH AND BRAKE SHAFT SEAL SET

Seals where rods go thru floor.



ORDER #785

**\$9<sup>00</sup>** pr.

## BRAKE BLEEDER SCREW

Requires 4 per car.

ORDER #1447

**\$3** ea.



## BRAKE SHOE RETURN SPRINGS

Sold in sets of 4.  
Need 8 springs per car.



ORDER #1423

**\$14<sup>00</sup>** set of 4

## 1953-54 BRAKE AND CLUTCH PAD

Replace worn pads with new pads.  
Look great!



ORDER #702

**\$8<sup>00</sup>** ea.

## BRAKE DRUM

New replacement.  
Ready to install.  
Fits Front or Rear

ORDER #1427

**\$72<sup>00</sup>** ea.



## 1953-54 CHROME EMERGENCY BRAKE HANDLE

ORDER #726

**\$32<sup>00</sup>** ea.



## BRAKE LIGHT SWITCH

Just like original!

ORDER #1332 **\$28<sup>00</sup>**



## BRAKE PEDAL RETURN SPRING

Connects to frame and brake pedal to return brake after use.

ORDER #1456 **\$11<sup>00</sup>**



## 1953-54 EMERGENCY BRAKE HANDLE

Original black bakelite handle.

ORDER #726B



**\$36<sup>00</sup>** ea.



# 1949-52 BRAKE LINES

Don't take chances on old, rusty or bent brake lines. Our brake lines are reproduced with the original contours and fittings and end caps keep lines free of moisture and dust until you are ready to use them. The front lines have steel wrap just like the original. A small price to pay to protect a large investment!



## BRAKE LINE PLACEMENT DIAGRAM

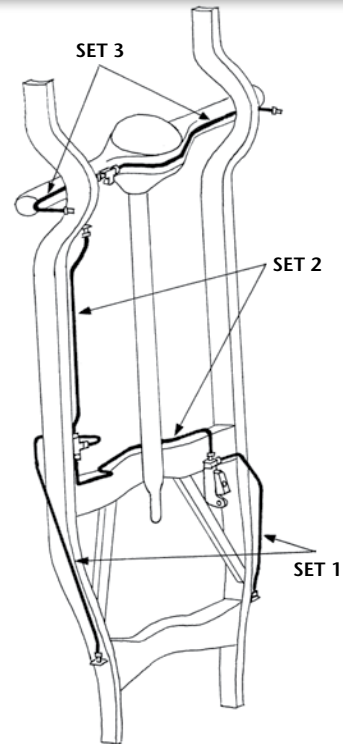

**SET 1:** Includes front driver side line and front passenger side line (2 clips required on this line - not included).

<b>1949-50</b>		
<b>ORDER #5412</b>	2- & 4-door sedan, coupe, station wagon, or sedan delivery stainless steel lines.....	<b>\$66<sup>00</sup></b> pr.
<b>ORDER #5414</b>	Hardtop stainless steel lines.....	<b>\$63<sup>00</sup></b> pr.
<b>ORDER #5416</b>	Convertible front stainless steel lines.....	<b>\$66<sup>00</sup></b> pr.
<b>1951-52</b>		
<b>ORDER #1432</b>	2- & 4-door sedan, coupe, station wagon, or sedan delivery stainless steel lines.....	<b>\$66<sup>00</sup></b> pr.
<b>ORDER #1442</b>	Hardtop stainless steel lines.....	<b>\$63<sup>00</sup></b> pr.
<b>ORDER #1434</b>	Convertible front stainless steel lines.....	<b>\$66<sup>00</sup></b> pr.

**SET 2:** Includes line that goes from master cylinder to passenger side and front to rear brake line (3 clips required on this line - not included)

<b>1949-50</b>		
<b>ORDER #5418</b>	2- & 4-door sedan, coupe, station wagon, or sedan delivery stainless steel lines.....	<b>\$67<sup>00</sup></b> pr.
<b>ORDER #5420</b>	Hardtop stainless steel lines.....	<b>\$67<sup>00</sup></b> pr.
<b>ORDER #5422</b>	Convertible stainless steel lines.....	<b>\$67<sup>00</sup></b> pr.
<b>1951-52</b>		
<b>ORDER #1436</b>	2- or 4-door sedan, coupe, station wagon or sedan delivery stainless steel lines.....	<b>\$67<sup>00</sup></b> pr.
<b>ORDER #1444</b>	Hardtop stainless steel lines.....	<b>\$67<sup>00</sup></b> pr.
<b>ORDER #1438</b>	Convertible stainless steel lines.....	<b>\$67<sup>00</sup></b> pr.

**SET 3:** Includes driver side rear line - all models, and passenger side rear line - all models.

<b>1949-50</b>		
<b>ORDER #5424</b>	All models stainless steel lines.....	<b>\$47<sup>00</sup></b> pr.
<b>1951-52</b>		
<b>ORDER #1440</b>	All models stainless steel lines.....	<b>\$47<sup>00</sup></b> pr.

# 1953-54 BRAKE LINES



Don't take chances on old, rusty or bent brake lines. Our brake lines are reproduced with the original contours and fittings and includes end caps to keep lines free of moisture and dust until you are ready to use them. The front lines have steel wrap, just like the original.



## 1949-54 BRAKE LINE FRAME CLIP

Sold Separately.  
Requires 5 per car

**ORDER #1418**  
**\$6<sup>00</sup>** ea.

**SET 1:** Includes front driver side line and front passenger side line (2 clips required on this line - not included)

2- & 4-door sedan, coupe, station wagon, or sedan delivery stainless steel lines	<b>ORDER #1432</b> <b>\$65.00</b> pr.
Hardtop stainless steel lines	<b>ORDER #1442</b> <b>\$63.00</b> pr.
Convertible front stainless steel lines	<b>ORDER #1434</b> <b>\$65.00</b> pr.

**SET 2:** Includes line that goes from master cylinder to passenger side and front to rear brake line (3 clips required on this line - not included)

2- or 4-door sedan, coupe, station wagon or sedan delivery stainless steel lines	<b>ORDER #1436</b> <b>\$67.00</b> pr.
Hardtop stainless steel lines	<b>ORDER #1444</b> <b>\$67.00</b> pr.
Convertible stainless steel lines	<b>ORDER #1438</b> <b>\$67.00</b> pr.

**SET 3:** Includes driver side rear line - all models, and passenger side rear line - all models.

All models stainless steel lines	<b>ORDER #1440</b> <b>\$47.00</b> pr.
----------------------------------	---------------------------------------

# EMERGENCY BRAKE CABLES, HANDLES, ETC.

## 1951-54 REAR BRAKE SHOE EMERGENCY BRAKE BAR SPRING

ORDER #1414

**\$5<sup>00</sup>** ea.

Sold separately -



Need 2  
per car.

## 1951-54 EMERGENCY BRAKE CABLE BOOT

If your cable is good  
but you need to  
replace the boots -  
here they are.



ORDER #1425

**\$8<sup>00</sup>** pr.

## 1951-54 EMERGENCY BRAKE CABLE SEAL

ORDER  
#1426



**\$6<sup>00</sup>** pr.



## EMERGENCY BRAKE CABLE AND BRACKET KIT

Emergency brake cable does not work with stock bracket.

Kit includes cables and bracket kit.

ORDER #1428-KIT **\$79<sup>00</sup>**



## 1949-54 EMERGENCY BRAKE CABLE BRACKET

Rear side bracket for emergency brake cable that clamps cable in place.

Includes brackets, bolts, nuts and washers.

ORDER #1463 **\$29<sup>00</sup>** pr.

# 1949-54 DUAL BRAKING SYSTEM

## 1949-54 STOCK MASTER CYLINDER REMOTE FILLER CONVERSION KIT

No more tearing up your carpet.

This kit adds a remote filler to your stock master cylinder reservoir. Install on inner fender.

ORDER #1464

**\$84<sup>00</sup>**





# MASTER CYLINDER AND RELATED PARTS

## 1950-54 POWERGLIDE CONVERSION KIT

Convert your standard master cylinder to powerglide. Kit is easy to install.

Instructions included.

ORDER #1422-KIT

**\$45<sup>00</sup>**



## 1950-54 CHEV PEDAL SHAFT LOCK PIN (STANDARD TRANSMISSION)

Machined and heat treated pin that holds the brake and clutch pedals in the Master Cylinder.



ORDER #1449

**\$35<sup>00</sup>**

## 1950-54 CHEV PEDAL SHAFT LOCK PIN (POWERGLIDE TRANSMISSION)

This machined and heat treated part holds the brake pedal in the Master Cylinder.



ORDER #1448

**\$35<sup>00</sup>**

## 1953-54 STANDARD TRANSMISSION MASTER CYLINDER

Brand new master cylinder to replace what can't be rebuilt. Fits cars with standard transmission only.

Rebuilt also available.

ORDER #1422 **\$150<sup>00</sup>** ea.



## 1949-52 MASTER CYLINDER

Brand new master cylinder to replace what can't be rebuilt. Powerglide cars will need to use the standard transmission master cylinder with a conversion kit.



1949-52  
STANDARD TRANSMISSION  
MASTER CYLINDER  
ORDER #5405

**\$150<sup>00</sup>**



1950-52 POWERGLIDE MASTER CYLINDER  
ORDER #5422PG

**\$199<sup>00</sup>**

## 1953-54 POWERGLIDE TRANSMISSION MASTER CYLINDER CONVERSION

Need a master cylinder for your powerglide equipped car?

We've come up with the solution to your problem!

Install a brand new standard transmission master cylinder with all the hardware to convert it to fit in your car.

(Includes instructions)



ORDER #1422PG

**\$199<sup>00</sup>**

## MASTER CYLINDER REBUILD KIT

Contains all needed parts to rebuild Master Cylinder

1949-52  
ORDER #5406

1953-54  
ORDER #1403

**\$30<sup>00</sup>**



## 1949-54 MASTER CYLINDER PLATE COVER GASKET

ORDER #1445

**\$5<sup>00</sup>** ea.



## 1949-54 MASTER CYLINDER COVER

Just like original.

ORDER #712

**\$14<sup>00</sup>**



# BRAKE HOSES, CLIP, JUNCTION BLOCK

## 1951-54 REAR BRAKE HOSE JUNCTION BLOCK

Replace that worn junction block with one that will last for 40 more years.

ORDER #1417

**\$52<sup>00</sup>**



## BRAKE HOSES

Replace brittle hoses with fresh ones that won't break if you touch them.

**\$22<sup>00</sup>** ea.



1949-50 FRONT HOSE

(Requires 2)

ORDER #5404F

1949-50 REAR HOSE

(Requires 1)

ORDER #5404R

1951-52 FRONT HOSE

(Requires 2)

ORDER #1404F

1951-52 REAR HOSE

(Requires 1)

ORDER #1404R

1953-54 FRONT HOSE

(Requires 2)

ORDER #1404F

1953-54 REAR HOSE

(Requires 1)

ORDER #1404R

## 1949-54 BRAKE HOSE RETAINING CLIP

ORDER #1419

**\$4<sup>00</sup>** ea.

Sold separately. Requires 3 per car.



# 1949-54 WHEEL CYLINDERS - REBUILD KITS

## REAR WHEEL CYLINDER

If you can't rebuild your old cylinders replace it with a new one.



1949-50  
ORDER #5410  
**\$80** ea.



1951-54  
ORDER #1408  
**\$60** ea.

## WHEEL CYLINDER REBUILD KITS

Contains all parts needed to rebuild your old wheel cylinders.



1949-50 FRONT KIT  
ORDER #5425  
**\$15<sup>00</sup>** ea.



1951-54 FRONT KIT  
ORDER #1407  
**\$13<sup>00</sup>** ea.



1951-54 REAR KIT  
ORDER #1409  
**\$13<sup>00</sup>** ea.

## 1951-54 WHEEL CYLINDER BRAKE SHOE PUSH ROD



ORDER #1413  
**\$5<sup>00</sup>** ea.

Sold separately - Need 8 per car.

## 1949-50 FRONT WHEEL CYLINDER



FRONT DRIVER SIDE  
ORDER #5409

FRONT PASSENGER SIDE  
ORDER #5408

**\$90<sup>00</sup>** ea.

## 1951-54 FRONT WHEEL CYLINDER

Old wheel cylinders can't be rebuilt?  
Replace it with a fresh new one.

ORDER #1405R PASS. SIDE  
ORDER #1406L DRIVER SIDE

**\$44<sup>00</sup>** ea.



*Our last  
Pomona Show  
2010*



# COOLING - HEATING SYSTEM

## 6 CYLINDER ALUMINUM RADIATOR

ORDER #7102

**\$299**



## 6 CYLINDER COPPER RADIATOR

Excellent replacement 3 core radiator.  
Fits 1949-54 cars.

Does not include petcock. (See below)  
STANDARD MODEL (6-cyl.)

ORDER #7101  
**\$475<sup>00</sup>**



## UPPER RADIATOR HOSE

Fits all models.

1949-54

ORDER #1116

**\$33<sup>00</sup>**



## LOWER RADIATOR HOSE

1949-54



For Cars  
with Standard  
Transmissions

ORDER #1117

**\$36<sup>00</sup>**

## LOWER RADIATOR HOSE

For Cars with Automatic  
Transmissions

ORDER  
#1118

**\$17**

1949-54



## THERMOSTAT

160°

ORDER #1323

**\$14<sup>00</sup>**

180°

ORDER #1324

**\$16<sup>00</sup>**



1949-54

## THERMOSTAT GASKET

ORDER #1353 **\$4<sup>00</sup>**

1949-54

## THERMOSTAT HOUSING TO HEAD GASKET

ORDER #1354 **\$4<sup>00</sup>**



## RADIATOR CAP

Fits 1949-54 cars.

4 LB. CAP

ORDER #1327

**\$16** ea.

7 LB. CAP

ORDER #1328

**\$16** ea.



## V-8 ALUMINUM RADIATOR

ORDER #7102-1

**\$289<sup>00</sup>**



## V-8 LOWER HOSE

ORDER #1117-1

**\$36<sup>00</sup>**



## V-8 UPPER HOSE

ORDER #1116-1

**\$30<sup>00</sup>**



# COOLING - HEATING SYSTEM

## RADIATOR PETCOCK

Fits all stock 1949-54 radiators.  
6 cylinder  
or V-8

ORDER  
#1147  
**\$8<sup>00</sup>**



## RADIATOR OVERFLOW CANISTER

Nice reproduction.  
Comes as kit.

ORDER #1956  
**\$120<sup>00</sup>**



## HEATER HOSE

3 piece set

1949-52 ORDER #5115

2 piece set

1953-54 ORDER #1115

1949-52  
hose  
pictured

**\$23<sup>00</sup>**



## 6 CYL. WATER PUMP

New - and  
includes gasket.

1949-52

ORDER #5326

1953-54

ORDER #1326

**\$149**



## WATER PUMP TO BLOCK GASKET

1949-54

ORDER #1396

**\$9<sup>00</sup>**



## REPLACEMENT HEATER CONTROL VALVE

Replace your leaking  
heater control valve  
with this unit. Not  
like the original, but it  
works great! Includes  
installation instruction.

1953-54

ORDER #1364

**\$89<sup>00</sup>**



## HEATER CONTROL VALVE SEAL

This will solve the problem of a  
leaky heater control valve but it  
is difficult to install.

1949-52  
ORDER  
#1360

**\$25**



## L HOSE

Short L shaped hose that connects heater  
control valve to heater core.

1949-54

ORDER #1365

**\$15<sup>00</sup>**



## RADIATOR SPEED NUT RETAINER

Slides behind radiator tabs -  
with threaded holes for bolts.

ORDER #1929

**\$20<sup>00</sup>** pr.



## RADIATOR SADDLE CUSHIONS & SHIMS

ORDER #1111

**\$13** set

*All Cars*



## RADIATOR SADDLE BOLTS

ORDER #1906

**\$6** Pr.

*All Cars*



## BELTS

Replace those worn belts with some strong, safe new ones.

### FAN BELTS

1949-52 ORDER #5315

1953-54 ORDER #1315

**\$20<sup>00</sup>**





# The ADVENTURES of **Barnie**

See the  
U.S.A.  
in your  
**CHEVROLET**

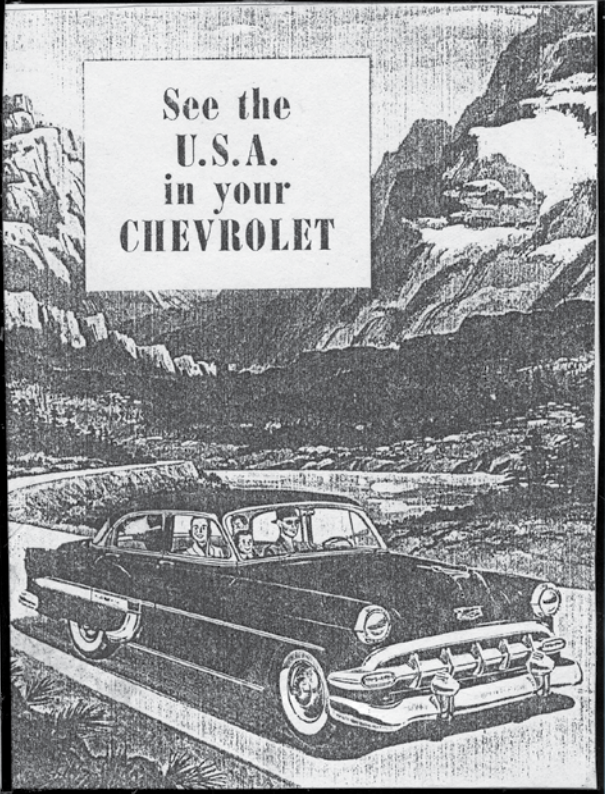

FANTASY.....

REALITY.....



DAVE REEVES 6-8-94



# 1949-54 WIRING HARNESSSES

## 1949-54 STARTER WIRE HARNESS

Goes from ignition to starter to distributor on standard transmission models or from ignition to starter to distributor and neutral safety switch on auto transmission models.



Tags mark wire placement.

12V harnesses include ballast resistors.

1949-52 12V AUTO ORDER #6450-S

**\$87**

1949-52 6V AUTO ORDER #6450-A

**\$75**

1949-52 6V STD. ORDER #6450-B

**\$75**

1949-52 12V STD. ORDER #6450-C

**\$87**

1953-54 12V AUTO ORDER #6450-P

**\$107**

1953-54 6V AUTO ORDER #6450-D

**\$95**

1953-54 12V STD. ORDER #6450-E

**\$87**

1953-54 6V STD. ORDER #6450-F

**\$95**

## 1949-54 HEADLIGHT BUCKET 6 OR 12V WIRES

Goes from headlights to junction blocks.



ORDER #2407

**\$59<sup>00</sup>**

## 1949-54 TAIL LIGHT HARNESS

Goes from dash to tail lights and includes sending unit dome light and license light wires.



1949, 50, 53 ORDER #6475-N

1949, 52, 54 ORDER #6475-S

**\$125**

## 1949-54 DASH HARNESS

From junction blocks to voltage regulator, **complete dash**, brake pedal, light switch dimmer switch and turn signal wires. 12V harness is wired for alternator and comes with new 6 terminal fuse block reducer. Wires are marked for placement. Starter wire **not** included.



**SPECIFY YEAR & MODEL**

1949 6V ORDER #6469-49

**\$379**

1950 6V ORDER #6469-50

**\$379**

1949-50 12V ORDER #6469-12V

**\$399**

1951-52 6V ORDER #6469-51-52

**\$379**

1951-52 12V ORDER #6469-1

**\$399**

1953-54 6V ORDER #6469-3

**\$379**

1953-54 12V ORDER #6469-4

**\$399**

## 1949-54 FRONT TURN SIGNAL HARNESS

Goes from junction block to front turn signals.

Tags mark placement.



1953-54 ORDER #6459-S

**\$27**

1949-52 ORDER #6459-N

pr.

## 1949-54 CONVERTIBLE POWER TOP HARNESS

Goes from dash knob to electric top motor.

1949-52

6V ORDER #6464-N

**\$39<sup>00</sup>**

12V ORDER #6464-12

**\$55<sup>00</sup>**

(includes reducer)

1953-54

6V ORDER #6464-6

**\$39<sup>00</sup>**

12V ORDER #6464-53

**\$55<sup>00</sup>**

(includes reducer)

**NOTE - We still have assorted cloth-covered wiring harnesses. Please call for discounted price/availability.**



## 1953/54 TURN SIGNAL SWITCH WIRING

ORDER #2434

**\$35<sup>00</sup>**

# 12V LIGHT BULB KITS

Contains all bulbs needed for 12V wiring kit. **Headlights not included.**



Actual kit not shown.

1949-50 ORDER #2435

**\$45<sup>00</sup>**

1953 ORDER #2438

**\$62<sup>00</sup>**

1951-52 ORDER #2437

**\$49<sup>00</sup>**

1954 ORDER #2439

**\$58<sup>00</sup>**



# WIRING



## 6V/12V COMPLETE WIRING HARNESSSES

**One harness does it all - Comes with everything you need.**

From headlights to tail lights, this wire harness is made like the original but with plastic-coated wire color coded with color diagrams for easy installation. Harnesses include headlight switch, junction blocks, dash sockets already wired in and grommets needed for wires to go through. Wires are also tagged for placement.

**NOTE: 12V cars will need alternator.**

**Alternator Bracket can be found on page 140.**

1954 Harness pictured.

### 6V SEDAN MODELS WITH STANDARD TRANSMISSION

1949	ORDER #6488-49	<b>\$575</b> ea.
1950	ORDER #6488-50	
1951-52	ORDER #6488-51-52	
1953	ORDER #6488-53	
1954	ORDER #6488-54	

### 6V SEDAN MODELS WITH AUTOMATIC TRANSMISSION

1949	ORDER #6489-49	<b>\$595</b> ea.
1950	ORDER #6489-50	
1951-52	ORDER #6489-51-52	
1953	ORDER #6489-53	
1954	ORDER #6489-54	

### 6V CONVERTIBLE WITH STANDARD TRANSMISSION

1949	ORDER #6490-49	<b>\$614</b> ea.
1950	ORDER #6490-50	
1951-52	ORDER #6490-51-52	
1953	ORDER #6490-53	
1954	ORDER #6490-54	

### 6V CONVERTIBLE WITH AUTOMATIC TRANSMISSION

1949	ORDER #6491-49	<b>\$634</b> ea.
1950	ORDER #6491-50	
1951-52	ORDER #6491-51-52	
1953	ORDER #6491-53	
1954	ORDER #6491-54	

### 6V HARDTOP MODELS WITH STANDARD TRANSMISSION

1950	ORDER #6497-50	<b>\$575</b> ea.
1951-52	ORDER #6497-51-52	
1953-54	ORDER #6497-53	
1954	ORDER #6497-54	

### 6V HARDTOP MODELS WITH AUTOMATIC TRANSMISSION

1950	ORDER #6497-50HT	<b>\$595</b> ea.
1951-52	ORDER #6497-51-52HT	
1953-54	ORDER #6497-53-54HT	

### 12V SEDAN MODELS WITH STANDARD TRANSMISSION

1949	ORDER #6492-49	<b>\$643</b> ea.
1950	ORDER #6492-50	
1951-52	ORDER #6492-51-52	
1953	ORDER #6492-53	
1954	ORDER #6492-54	

### 12V SEDAN MODELS WITH AUTOMATIC TRANSMISSION

1949	ORDER #6493-49	<b>\$663</b> ea.
1950	ORDER #6493-50	
1951-52	ORDER #6493-51-52	
1953	ORDER #6493-53	
1954	ORDER #6493-54	

### 12V CONVERTIBLE WITH STANDARD TRANSMISSION

1949	ORDER #6494-49	<b>\$694</b> ea.
1950	ORDER #6494-50	
1951-52	ORDER #6494-51-52	
1953	ORDER #6494-53	
1954	ORDER #6494-54	

### 12V CONVERTIBLE WITH AUTOMATIC TRANSMISSION

1949	ORDER #6495-49	<b>\$714</b> ea.
1950	ORDER #6495-50	
1951-52	ORDER #6495-51-52	
1953	ORDER #6495-53	
1954	ORDER #6495-54	

### 12V HARDTOP MODELS WITH STANDARD TRANSMISSION

1950	ORDER #6496-50	<b>\$643</b> ea.
1951-52	ORDER #6496-51-52	
1953-54	ORDER #6496-53-54	

### 12V HARDTOP MODELS WITH AUTOMATIC TRANSMISSION

1950	ORDER #6496-50HT	<b>\$663</b> ea.
1951-52	ORDER #6496-51-52HT	
1953-54	ORDER #6496-53-54HT	

# 6V TO 12V CONVERSION KITS

## ALTERNATOR BRACKET AND INSTRUCTIONS

Kit contains bracket, instructions for conversion and alternator wide belt pulley.



1949-52  
ORDER #2430-4  
**\$120<sup>00</sup>**

**2** This kit contains alternator bracket, instructions, fuel gauge reducer, reducers, horn relay, flasher, ballast resistor, DA plug and harness, 12V coil and alternator wide belt pulley.



1949-50  
ORDER #7190-1

1951-52  
ORDER #7190-2  
**\$265<sup>00</sup>**

**3** This kit contains alternator bracket, instructions, reducers, fuel gauge reducer, horn relay, flasher, ballast resistor, DA plug, harness and light bulbs, 12V coil and alternator wide belt pulley.



1949-50  
ORDER #7190-3  
1951-52  
ORDER #7190-4  
**\$400<sup>00</sup>**

## FULL KIT

This kit contains alternator bracket, instructions, reducers, horn relay, flasher, ballast resistor, D.A. plug and harness. All light bulbs required and fuel gauge reducer, and 12V coil.

1953 ORDER #2430-3  
1954 ORDER #2431-3

**\$375<sup>00</sup>**



**YOU WILL NEED TO PURCHASE AN ALTERNATOR FOR ANY KIT.**

**NOTE: ALL KITS REQUIRE AN ALTERNATOR.**

## BRACKET AND INSTRUCTIONS

Alternator bracket and instructions for conversion. 1953 or 1954

ORDER #2430-1  
**\$80<sup>00</sup>**



## PARTIAL KIT

This kit contains alternator bracket, instructions, reducers, fuel gauge reducer, horn relay, flasher, ballast resistor, D.A. plug and harness and 12V coil.

1953  
ORDER #2430-2  
1954  
ORDER #2431-2  
**\$240<sup>00</sup>**



## ALTERNATOR BRACKET

Fits 216/235 engine where stock generator attaches.

ORDER #2148  
**\$70<sup>00</sup>**

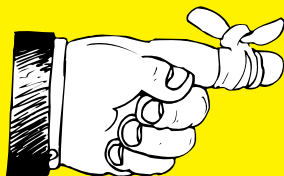

Whether by phone, fax, mail or email...  
**PLEASE BE SURE TO USE PART NUMBERS WHEN ORDERING.**

*This is the only way we can be sure of what you want and avoid costly mistakes.*



# 6 VOLT LAMPS



## TAIL LIGHTS

### 1949-52 — ALL MODELS

Running, Brake & Signal

### 1953 — ALL MODELS

Upper (Running)

Center (Stop)

Lower (Backup)

### 1954 — ALL MODELS

Upper (Running, brake, signal)

Lower (Backup)

All Cars "Bright Bulb" (Lights up brighter)

## PARK LIGHT

1949-52 All Models

1953 All Models

1954 All Models

## DOME LIGHTS

1949-54 Sedan, Coupe, Station Wagon

1950-54 Hardtop (2 per car)

1949-54 Convertible

## GLOVE BOX

1949-52 All Models

1953-54 All Models

## RADIO

1949-52 All Models

1953-54 All Models

## INSTRUMENT PANEL

1949-54 High Beam Indicator - All Models

1949-50 Dash Light (Requires 2)

1951-54 Dash Light (Requires 4)

1953-54 Directional Signal (Requires 2)

## CLOCK

1949-52 All Models

1953-54 All Models

## IGNITION

1949-54 All Models

## LICENSE LIGHT

1949-50 (Requires 2)

1951-52 (Requires 1)

1953-54 Sedan, HT, Convertible

1949-54 Sedan Delivery, Wagon

## LIGHTED ACCESSORIES

Underhood Lamp - All Years

Trunk Light - All Years

1953-54 Courtesy Lamp

1949-54 Transmission Control Indicator Lamp

All Models with Auto Transmission

Order #1804 **\$4<sup>00</sup>** ea.

Order #1801 **\$3<sup>00</sup>** ea.

Order #1802 **\$5<sup>00</sup>** ea.

Order #1803 **\$5<sup>00</sup>** ea.

Order #1804 **\$4<sup>00</sup>** ea.

Order #1805 **\$5<sup>00</sup>** ea.

Order #1825 **\$5<sup>00</sup>** ea.

Order #1806 **\$4<sup>00</sup>** ea.

Order #1806 **\$4<sup>00</sup>** ea.

Order #1807 **\$4<sup>00</sup>** ea.

Order #1808 **\$6<sup>00</sup>** ea.

Order #1809 **\$4<sup>00</sup>** ea.

Order #1810 **\$4<sup>00</sup>** ea.

Order #1815 **\$3<sup>00</sup>** ea.

Order #1811 **\$3<sup>00</sup>** ea.

Order #1815 **\$4<sup>00</sup>** ea.

Order #1812 **\$3<sup>00</sup>** ea.

Order #1814 **\$3<sup>00</sup>** ea.

Order #1815 **\$3<sup>00</sup>** ea.

Order #1815 **\$3<sup>00</sup>** ea.

Order #1813 **\$3<sup>00</sup>** ea.

Order #1815 **\$3<sup>00</sup>** ea.

Order #1816 **\$3<sup>00</sup>** ea.

Order #1817 **\$3<sup>00</sup>** ea.

Order #1818 **\$3<sup>00</sup>** ea.

Order #1818 **\$3<sup>00</sup>** ea.

Order #1818 **\$3<sup>00</sup>** ea.

Order #1819 **\$3<sup>00</sup>** ea.

Order #1822 **\$3<sup>00</sup>** ea.

Order #1823 **\$3<sup>00</sup>** ea.

Order #1824 **\$4<sup>00</sup>** ea.

Order #1821 **\$2<sup>00</sup>** ea.



## 1949-54 6 VOLT HALOGEN HEADLIGHT BULBS

Order #1820  
**\$24<sup>00</sup>** ea.

## 1949-54 JUNCTION BLOCK TERMINAL

Just like the original — excellent replacement  
for old terminals. Requires 2 per car.



ORDER #1376 **\$17** ea.

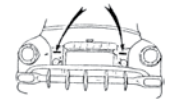

## ORIGINAL STYLE 6V HEADLIGHT SWITCH

Replace worn out switch with a new one. Use your old knob.



1949-54 Cars

ORDER #1333  
**\$75<sup>00</sup>**

## 1949-54 6V TURN SIGNAL FLASHER

Turn signal problems? Try a new flasher.

ORDER #1358  
**\$15<sup>00</sup>**



## 1949-54 12V HEADLIGHT SWITCH

Original Design

ORDER #1333-12V **\$75**



## FUEL GAUGE REDUCER

Converted to 12 Volts? Use this reducer to  
prevent burning out your fuel gauge.

Installation instructions included.

ORDER #2143 **\$14<sup>00</sup>**



## 1949-54 HEADLIGHT DIMMER SWITCH

Replaces your non-working one.

ORDER #1350 **\$34<sup>00</sup>**



# 1949-54 FRONT SUSPENSION

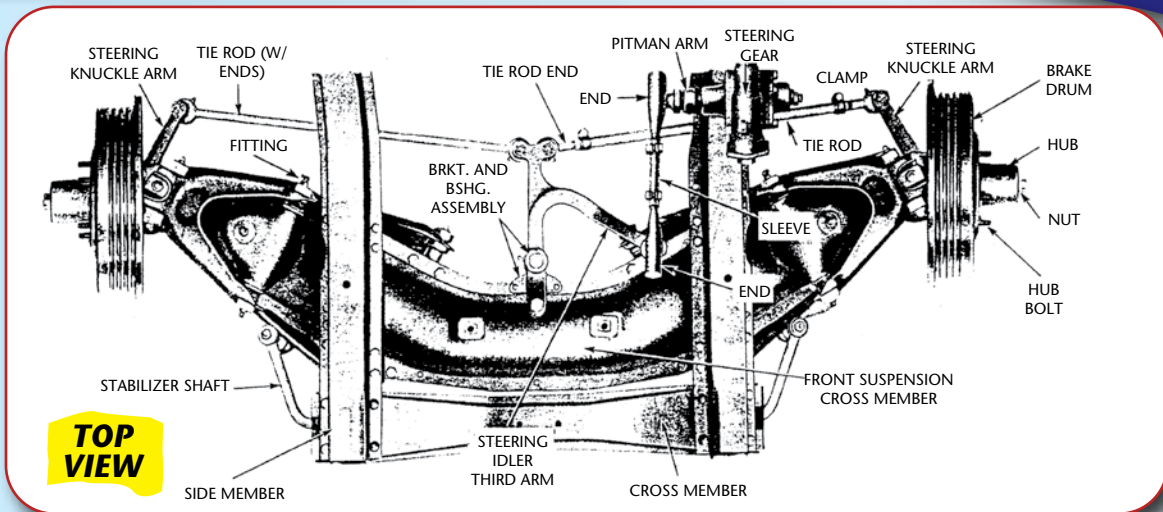

**TOP VIEW**

## INNER PINS



UPPER

ORDER #1509

**\$105** ea.



LOWER

ORDER #1510

**\$125** ea.

## PASSENGER SIDE TIE ROD

This assembly replaces the original non-adjustable tie rod with an adjustable unit.



ORDER #1501-A

**\$85<sup>00</sup>**

## LOWER STEERING COLUMN CONVERSION BEARING

This bearing can be used when converting to a newer column using the stock gear box or when using stock column and a new gear box or rack.



ORDER #1560

**\$19<sup>00</sup>**

## PASSENGER SIDE TIE ROD

(Not Adjustable)  
(DRAG LINK)



ORDER #1501

**\$195<sup>00</sup>**

## IDLER ARM PIN KIT

ORDER #1504

**\$73<sup>00</sup>**



## KING PIN SET

ORDER #1505

**\$70<sup>00</sup>**



## TIE ROD END BOOT

Replace missing boots from tie rods.



ORDER #1519

**\$6<sup>00</sup>** ea.

## DRIVER SIDE TIE ROD (Adjustable)



INNER TIE ROD END  
ORDER #1502 **\$32<sup>00</sup>**

OUTER TIE ROD END  
ORDER #1503 **\$32<sup>00</sup>**



TIE ROD END CLAMP  
ORDER #1525 **\$24<sup>00</sup>** pr.

## OUTER PINS

UPPER

Used to set wheel camber.

ORDER #1507

**\$90** ea.



LOWER

ORDER #1508

**\$75** ea.





# FRONT SUSPENSION

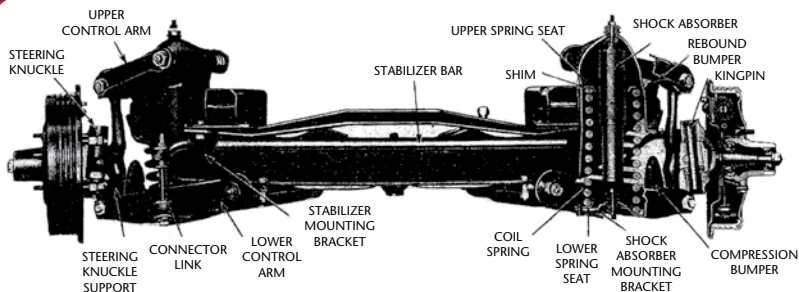

## STABILIZER BAR ENDS (BOTH SIDES)

ORDER #1506

**\$27**



## FRONT COIL SPRINGS

Front end sagging? Lift it up with these new coil springs.

1953-54  
ORDER #1527

**\$155<sup>00</sup>** pr.

1949-52  
ORDER #5527

**\$197<sup>00</sup>** pr.

## UPPER SUSPENSION BUMPER

Requires 2 per car.



ORDER #1514 **\$13** pr.

## LOWER SUSPENSION BUMPER

Requires 2 per car.



ORDER #1513 **\$19** pr.

## REPLACEMENT RUBBER BUSHINGS

For front end components.

Some replacements may require 2 bushings.

ORDER #1531

**\$11<sup>00</sup>** set of 20

## GREASE FITTINGS

18-pc. kit to replace old fittings.



ORDER #1526 **\$11<sup>00</sup>** kit

## FRONT SWAY BAR BUSHING

Replace worn bushings.

ORDER #1528

**\$14<sup>00</sup>** pr.

## STEERING ROD CONNECTOR SEAL

(Requires 2 per car)



ORDER #1532 **\$16** ea.

# 1949-54 SHOCKS

Ever watch a car go down the road that needs new shocks? Watch it bounce up and down? Don't let your car look that way. It's not cool! Replace broken or tired shocks with these new antique auto shocks. Improve your ride. Includes hardware. Sold in pairs.

## FRONT SHOCKS

ORDER #1516

**\$92<sup>00</sup>** pr.

## REAR SHOCKS

ORDER #1517

**\$98<sup>00</sup>** pr.



## SHOCK BUMPER

Available singly if you just need one.

ORDER #1523

**\$5<sup>00</sup>** ea.



## FRONT SHOCK BRACKET

After forty-some years, these are tired.

Replace them before they break.

ORDER #1515

**\$21** ea.



## SHOCK BUMPER KIT

Does all 4 shocks. Includes washers.

ORDER #1523KIT

**\$15**



# 1949-54 REAR SUSPENSION



## LEAF SPRINGS

Broken springs? Replace them with these all-new steel springs. Like the original with 7 leaves. Black in color. Fits all models. Includes new spring flange bushing.

ORDER #1530  
**\$410<sup>00</sup>** pr.

## U BOLTS

Replace tired old bolts now to avoid future problems. Includes U-Bolt style washers and nuts. *Set does one side only.*



ORDER #1522 **\$35** set of 2



## SPRING SHACKLE

Replaces worn or broken parts. Includes new rubber bushings. Requires 2 per car.

ORDER #1529 **\$35<sup>00</sup>** ea.

## SHACKLE BUSHINGS

New rubber replacement bushings. Sold by set. 2 sets required per car.

ORDER #1518  
**\$16<sup>00</sup>** set of 4



## SPRING FLANGE BOLT

Replace worn bolts with new ones.

ORDER #1521  
**\$5<sup>00</sup>** each



## SPRING FLANGE (Bushing)

Fits on front of rear spring. Requires 2 per car.

ORDER #1520  
**\$18** ea.



## LOWERING BLOCK KIT

Drop it the way you want it.

Kit includes: 1" and 1 3/4" blocks and 4 "U" bolts. "U" bolts are a little longer if you wish to use a bigger drop.

ORDER #2140  
**\$99<sup>00</sup>** set

*Blocks are solid aluminum.*

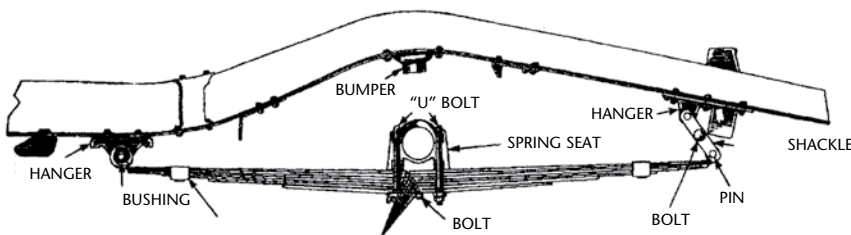

## REAR SPRING AND PARTS

The diagram may not be the actual 1953/54 rear suspension, but can be used as a guide to show you where parts go.

## NOTICE:

*Prices in catalog subject to change without notice.  
 Internet prices are current.*



# 1949-52 FIREWALL PAD/GROMMETS



## INSULATION PAD

Not an exact reproduction, but works very well. Thicker than before for better sound control. Glue installation. No clips.

ORDER #4711 **\$79<sup>00</sup>**

## 1 SPEEDOMETER AND HEADLIGHT WIRE HARNESS GROMMET

ORDER #602



**\$10<sup>00</sup>**

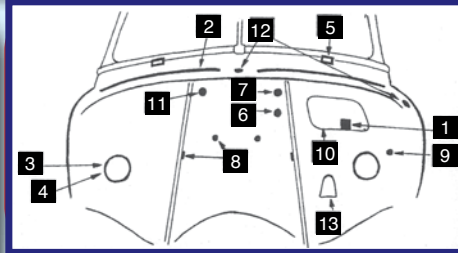

## 2 1949-52 COWL SEAL

Correct two-piece cowl seal.

ORDER #4603

**\$12<sup>00</sup>**



## 5 WIPER TRANSMISSION GASKET

ORDER #4610

**\$7<sup>00</sup>** pr.



## 3 FRESH AIR INLET SLEEVE

ORDER #605

**\$8<sup>00</sup>** pr.



## 4 FRESH AIR INLET FELT GASKET

ORDER #606

**\$9** pr.



## 6 STARTER WIRE HARNESS GROMMET

ORDER #612

**\$7<sup>00</sup>**



## 8A 1949-50 VENT CABLE GROMMET SET

(4 pcs.)

ORDER #4611

**\$23<sup>00</sup>**



## 7 WATER TEMP, WIPER AND OIL PRESSURE LINE GROMMET

ORDER #613

**\$15**



## 8B 1951-52 PASSENGER VENT CABLE GROMMETS

(2 pcs.)

ORDER #615

**\$17<sup>00</sup>**



## 9 FIREWALL PLUG

(Hole to use as grommet for neutral safety switch wires)

ORDER #616

**\$9<sup>00</sup>**



## 10 VOLTAGE REGULATOR PLATE TO FIREWALL SEAL

ORDER #618

**\$13<sup>00</sup>**



## 11 FIREWALL PLUG/GROMMET CIGARETTE LIGHTER WIRE

(1949-50 used as grommet, '51-52 plug)

ORDER #4612

**\$7<sup>00</sup>**



## 12 COWL PLUGS

Top center plug and driver side plug/grommet for antenna.

ORDER #601-14

**\$8<sup>00</sup>** pr.



## 13A STEERING COLUMN TO FIREWALL SEAL

(Installs from inside)

ORDER #720

**\$14<sup>00</sup>**



## 13B STEERING COLUMN TO FLOOR SEAL

(Installs from inside over firewall pad)

ORDER #719

**\$19<sup>00</sup>**



## COWL SEAL CLIPS

Clips and screws that hold cowl seal in place.

ORDER #601-21

**\$12<sup>00</sup>** set



## REPLACEMENT UNDERHOOD WIRING HARNESS CLIP SET

ORDER #601-24

**\$40<sup>00</sup>** set



## CLUTCH HEAD SCREW SET

Contains all screws in engine compartment.

ORDER #601-23

**\$24<sup>00</sup>**



Newsletters are available **FREE** in full color at [www.49-54nca.com](http://www.49-54nca.com)

# 1953-54 FIREWALL PAD / GROMMETS



## FIREWALL INSULATION PAD

Not an exact reproduction, but bottom looks like it. Works and fits very nicely and is thicker for more sound control. Great new price too! Glue installation - no clips.

ORDER #711 *Only* **\$79<sup>00</sup>**

## FIREWALL GROMMETS

**1** **SPEEDOMETER AND HEADLIGHT WIRE HARNESS GROMMET**  
  
 ORDER #602 **\$10<sup>00</sup>**

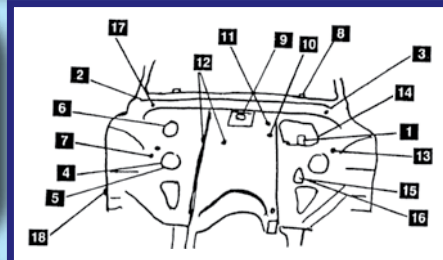

**2** **1953 COWL SEAL**  
 ORDER #603 **\$12**  
**3** **1954 COWL SEAL**  
 ORDER #604 **\$12**  

**4** **FRESH AIR INLET SLEEVE**  
 ORDER #605  
**\$8<sup>00</sup>** pr.  

**5** **FRESH AIR INLET FELT**  
 ORDER #606  
**\$9<sup>00</sup>** pr.  

**6** **HEATER MOTOR TO FIREWALL SEAL**  
  
 ORDER #607 **\$9<sup>00</sup>**

**7** **FIREWALL HEATER HOSE GROMMET**  
  
 ORDER #608 **\$7<sup>00</sup>**

**8** **WIPER TRANSMISSION GASKET**  
 ORDER #610  
**\$7<sup>00</sup>** pr.  

**9** **AUXILIARY WIPER DRIVE SEAL**  
  
 ORDER #611 **\$9<sup>00</sup>** pr.

**10** **FIREWALL GROMMET FOR STARTER WIRE HARNESS**  
  
 ORDER #612 **\$7<sup>00</sup>**

**11** **FIREWALL GROMMET FOR WATER TEMP, WIPER AND OIL PRESSURE LINE**  
  
 ORDER #613 **\$15<sup>00</sup>**

**12** **FIREWALL PLUG FOR RIGHT VENT**  
 (2 pcs.)  
 ORDER #615  
**\$16<sup>00</sup>**  

**13** **FIREWALL PLUG UNIVERSAL PLUG**  
 ORDER #616  
**\$9<sup>00</sup>**  

**14** **WIRING HARNESS COWL TO FIREWALL SEAL**  
 (Fits behind voltage regulator)  
 ORDER #618  
**\$12<sup>00</sup>**  

**15** **STEERING COLUMN TO FIREWALL SEAL**  
 (Installs from Inside)  
  
 ORDER #720 **\$14<sup>00</sup>**

**16** **STEERING COLUMN TO FLOOR SEAL**  
 (Installs from Inside - Over Carpet)  
  
 ORDER #719 **\$19<sup>00</sup>**

**17** **ACCESS PLUG ON TOP OF COWL**  
 ORDER #601-14  
**\$8<sup>00</sup>** pr.  

**COWL SEAL CLIPS**  
  
 Clips and screws that hold cowl seal in place.  
 ORDER #601-21 **\$12** set

**REPLACEMENT UNDERHOOD WIRING HARNESS CLIP SET**  
  
 ORDER #601-24 **\$40** set

**CLUTCH HEAD SCREW SET**  
 Contains all screws in engine compartment.  
 Order #601-23  
**\$24<sup>00</sup>**  

**18** **ACCESS PLUG ON LOWER COWL SIDE**  
 ORDER #601-17  
**\$8<sup>00</sup>** pr.  



# 1949-54 HEADLIGHT SEALS, HARDWARE & SPRINGS

**1** Headlight wire harness grommet.  
Fits to side of radiator

ORDER #614 **\$7<sup>00</sup>** pr.



**2** Generic headlight bezel seal  
without wire core (just slips on)

ORDER #1616 **\$11<sup>00</sup>** pr.



**2A** Headlight Bezel Seal. Like original with wire core.  
Instructions for bending included.

ORDER #1606 **\$24<sup>00</sup>**



**3** Headlight bucket gasket  
(seals rear of bucket to body of car) (pr)

ORDER #1605 **\$9<sup>00</sup>** pr.



**4** Main front wire harness grommet (carries headlight,  
turn signal, horn wires to front of radiator)

ORDER #601-18 **\$5<sup>00</sup>**



## HEADLIGHT HOUSING SCREW SET

Attaches headlight buckets  
to fenders.

ORDER #1610 **\$12<sup>00</sup>** set



## HEADLIGHT BUCKET GROMMET

Fits on back of  
headlight  
bucket - carries wires.

ORDER #1607 **\$9<sup>00</sup>** pr.

## 1949-52 HEADLIGHT ASSEMBLY

Comes with 12V bulb,  
original style loom,  
original style wiring.

ORDER #1620-1

**\$103** ea.



## 1949-54 HEADLIGHT BUCKET ADJUSTING SPRING

ORDER #1619 **\$8<sup>00</sup>** ea.

## 1949-54 HEADLIGHT BULB RETAINING RINGS

ORDER #1617 **\$14** ea.

## 1949-54 HEADLIGHT BUCKET



Good solid metal bucket to  
replace your old rusty ones.

ORDER #1618  
**CALL FOR AVAILABILITY**

## 1949-52 HEADLIGHT BEZELS

Excellent stainless steel reproduction  
of originals.

ORDER #4307 **\$20** ea.



## 1949-52 HEADLIGHT RIM CLIPS

Does both sides.

ORDER #4308 **\$7<sup>00</sup>** set



## 1954 HEADLIGHT RIM

Great reproduction. Everything you need to replace dented  
or scratched headlight rims.

1 Rim Only - Includes rim, gasket, clips, screw. ORDER #507-1 **\$69**

2 Rims Only - Includes rims, gaskets, clips, screws. ORDER #507-2 **\$135**



## COMPLETE HEADLIGHT BUCKET ASSEMBLY

Fits 1949-52. Includes 12V headlight bulb, inner bucket, outer bucket,  
plastic wiring. Have also been able to use on 1953-54 cars.

ORDER #1620 **\$75** ea.

# ANTI-SQUEAK KITS / BODY TO FRAME PADS

## FRONT FENDER ANTI SQUEAK KIT

All pieces needed to assemble front fenders to inner fenders.  
Includes front fender "U" seals and radiator shims.

1949-50

ORDER #5511



1951-52

ORDER #5512

1953

ORDER #1511

1954

ORDER #1512

**CALL FOR AVAILABILITY**

## BODY TO FRAME PADS

For the body-off restoration, frame pads are a must.



1949-52 SEDAN

ORDER #5513

1949-52 COUPE, HARDTOP,  
CONVERTIBLE

ORDER #5514

1953-54 SEDAN

ORDER #1109

1953-54 HARDTOP

ORDER #1110

1953-54 CONVERTIBLE

ORDER #1110C

**\$34**

## '53-'54 FRONT CLIP ASSEMBLY KIT

Contains all bolts, nuts, washers, etc.  
to reassemble front clip.  
(Fenders, inner fenders)



ORDER #1905

**\$29<sup>00</sup>**

## 1949-54 FRONT FENDER "U" SEAL



U-shaped seal that seals  
rear inner fender  
to fender.

ORDER #609

**CALL FOR AVAILABILITY**

## 1949-54 RADIATOR SADDLE CUSHIONS & SHIMS

ORDER #1111

**\$18<sup>00</sup>** set



## 1949-52 STEERING GEAR BOX SEAL

Seals driver side inner fender  
to steering box.

ORDER #5515

**\$14<sup>00</sup>**



## 1949-54 RADIATOR SADDLE BOLTS

ORDER #1906

**\$8<sup>00</sup>** pr.



## 1949-52 FRONT CLIP ASSEMBLY KIT

Contains all nuts, bolts, washers, etc. to  
reassemble front clip. (Fenders, inner fenders)

ORDER #5516

**\$40<sup>00</sup>**





# 1949-52 HOOD GROMMETS, SEALS, BOLTS & SPRINGS

## 5 1949-52 HOOD SPRINGS

Replace those sagging hood springs.  
Remanufactured to original specifications with black powder coat finish.



ORDER #5356

**\$58<sup>00</sup>** pr.

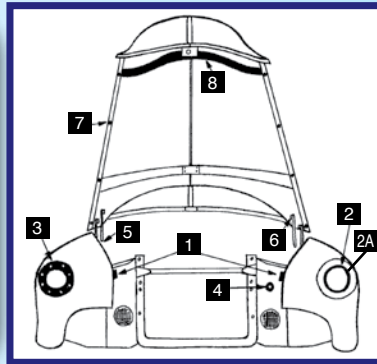

## 6 1949-54 HOOD BOLTS

Replace one or all four.



Top quality hood bolts made with proper shoulder just like the original.

ORDER #1385

**\$5<sup>00</sup>** ea.

SET OF 4

ORDER #1385-4

**\$18<sup>00</sup>**

## 1949-54 HOOD SPRING REMOVAL TOOL



Using this tool is the best and easiest way to remove old hood springs and install new ones. Comes with instruction sheet.

ORDER #1357

**\$49<sup>00</sup>** pr.

## 7 HOOD GROMMET KIT

Includes all grommets on side of hood, grill bumpers and hood rest bumpers.

ORDER #4601-5

**\$18<sup>00</sup>** set



## 8 HOOD BRACE SEAL

Seals top of radiator to hood when hood is closed.



ORDER #619

**\$18<sup>00</sup>**



## 1949-54 HOOD ASSEMBLY KIT

Hood taken apart? Put it back together with this handy kit that has everything you need to do the job.

ORDER 601-25

**\$18<sup>00</sup>** pr.

# 1953-54 HOOD GROMMETS, BOLTS, SPRINGS, TOOLS

## 5 REPLACE THOSE SAGGING HOOD SPRINGS ON YOUR CAR

1953/54 CHEV HOOD SPRINGS

Remanufactured to original specifications.

ORDER #1356

**\$58<sup>00</sup>** pr.

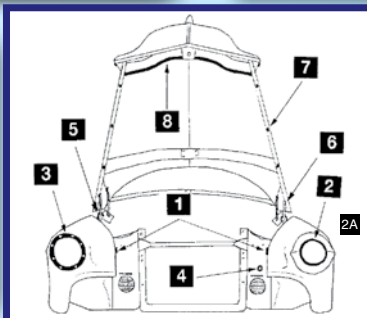

## 6 REPLACE ONE, OR ALL FOUR, IF YOU NEED TO.

1949-54 CHEV HOOD BOLTS

Top quality hood bolts made with proper shoulder just like the original.

ORDER #1385

**\$5<sup>00</sup>** ea.



## 1949-54 HOOD SPRING REMOVAL TOOL

Using this tool is the best and easiest way to remove old hood springs and install new ones. Comes with instruction sheet.

ORDER #1357

**\$49<sup>00</sup>** pr.



## 7 1953-54 HOOD GROMMET KIT

Includes all grommets on side of hood, grill bumpers and hood rest bumpers.

ORDER #601-5

**\$18<sup>00</sup>**



## 8 1949-54 HOOD BRACE SEAL

Goes under bottom of hood as seal between top of radiator and hood.

ORDER #619

**\$18<sup>00</sup>**



# SOUND CONTROL

## UNDER HOOD INSULATION PAD

Durable light weight high performance sound absorption with this acoustical panel made from recycled cotton. 2 piece set, 1" thick and pre-cut for easy installation. Fits all models.

1949-52  
ORDER #7187-9

1953-54  
ORDER #7187

**\$99<sup>00</sup>** set



## FLOOR PAN INSULATION

This 3-piece set  
glues to floor  
before carpet  
pad is installed.  
Fits all models.

1949-52  
ORDER  
#4717-32

1953-54  
ORDER #7186

**\$45** set



## ROOF PANEL INSULATION KIT

Glue to roof before headliner is installed for sound control.  
5 piece set.

1949-52 ORDER #4717-31  
1953-54 ORDER #7185

**\$45** set



## KICK AND DECK PANEL SOUND DEADENING KIT

Uses thin padding under your deck panel and behind your kick panels for a quieter ride.

1949-52 STYLELINE 2 & 4 DOOR. SEDAN  
ORDER #6485

1949-52 COUPE  
ORDER #6485-1

1949-52 HARDTOP  
ORDER #6485-2

1949-52 FLEETLINE 2 & 4 DOOR SEDAN  
ORDER #6486

1953-54 COUPE  
ORDER #798

1953-54 2 & 4 DR. SEDAN  
ORDER #798-1

1953-54 HARDTOP  
ORDER #798-2



## KICKS ONLY

1949-52 ORDER #6487  
1953-54 ORDER #798-3

**\$14<sup>00</sup>** pr.

*Prices in catalog  
are subject to change  
without notice.*

*Prices at  
[www.nationalchevyassoc.com](http://www.nationalchevyassoc.com)  
are always current.*



# MUFFLERS, EXHAUST SYSTEMS & PARTS

## 1949-52 COMPLETE EXHAUST SYSTEMS

Replace your exhaust system *right in your own garage*. Aluminized tubing is used to eliminate future rust problems and improve appearance. Exhaust systems are bent to original specifications using state-of-the-art bending equipment to make installation trouble free. Each system is complete, including correct muffler, exhaust donut, clamps, and universal tailpipe hangers.

(Note: Original style tailpipe hanger sold separately.)

Complete **\$231<sup>00</sup>**



- 1949-52 with standard transmission (216 engine) except convertible..... Order #6010
- 1950-52 with Powerglide transmission (235 engine) except convertible... Order #2010-3
- 1949-52 Convertible with standard transmission (216 engine) ..... Order #6011
- 1950-52 Convertible with Powerglide transmission (235 engine) ..... Order #6012
- 1949-52 Stn. Wgn./Sed. Del. with standard trans. (216 engine) ..... Order #6013
- 1950-52 Stn. Wgn./Sed. Del. with Powerglide trans. (235 engine) ..... Order #2013

## 1953-54 COMPLETE EXHAUST SYSTEMS

Replace your exhaust system right in your own garage. Exhaust tubing is aluminized to eliminate future rust problems and improve appearance.

Exhaust systems are bent to original specifications using state-of-the-art bending equipment to make installation trouble free.

Each system is complete, including correct muffler, exhaust donut, clamps, and universal tailpipe hangers.

(Note: Original style tailpipe hanger sold separately.)

2 AND 4 DOOR SEDAN, COUPE

HARDTOP

CONVERTIBLE

STATION WAGON, SEDAN DELIVERY

1953

ORDER #2010-3

ORDER #2011-3

ORDER #2012

ORDER #2013

**\$231** ea.

1954

ORDER #2010-4

ORDER #2011-4

ORDER #2012

ORDER #2013-4

**\$241** ea.

\*Oversize Shipping

## COMPLAINT BOX



Please write legibly.

## STAINLESS EXHAUST DEFLECTOR

Made of heavy stainless with bowtie stamped in.

Hardware not included.

ORDER #512

**\$23<sup>00</sup>** ea.



## STAINLESS EXHAUST DEFLECTOR WITH RED REFLECTOR JEWEL

ORDER #573

**\$29** ea.



## 2 1/2" STAINLESS TIPS

Finishing touch for your dual exhaust system.

ORDER #2150

**\$79** pr.

1949-54



# CUSTOM EXHAUST



## COMPLETE DUAL EXHAUST SYSTEM WITH NEW "Williams Headers" FOR 1949-54 CHEV

\*Oversize  
Shipping

**\$695<sup>00</sup>**  
COMPLETE

New "WILLIAMS" CAST  
IRON HEADERS



Nothing can beat the sound of the "Split Six" Dual Exhaust! This complete dual exhaust system has been designed for the do-it-yourselfer, and can be installed right in your own backyard or garage. All exhaust pipes are pre-bent, to fit and are made of aluminized tubing for long lasting life. Williams Exhaust Headers will improve performance, and glass packed mufflers will give your car the sound made famous in the 50's. Complete with all necessary hardware and installation instructions. (Clamps, hangers, donuts, etc.) **"RAP" THEM PIPES!**

**DUAL EXHAUST SYSTEM W/GLASS PACK MUFFLERS** ORDER #2017  
**FOR 1949-54 CONVERTIBLES** ORDER #2017C

## WILLIAMS EXHAUST HEADERS

These are the new Williams Headers that made the Chevy "Split 6" exhaust system a legend! Will improve engine performance and give your car the sound "Oldtimers" will recognize blocks away. We include a few installation tips to help you out. Will not work on 1953-54 with power steering. Includes gaskets, flanges & hardware.  
**Fits all after-market intakes. Made in the U.S.A.**



ORDER  
#2014-W

**\$295<sup>00</sup>**

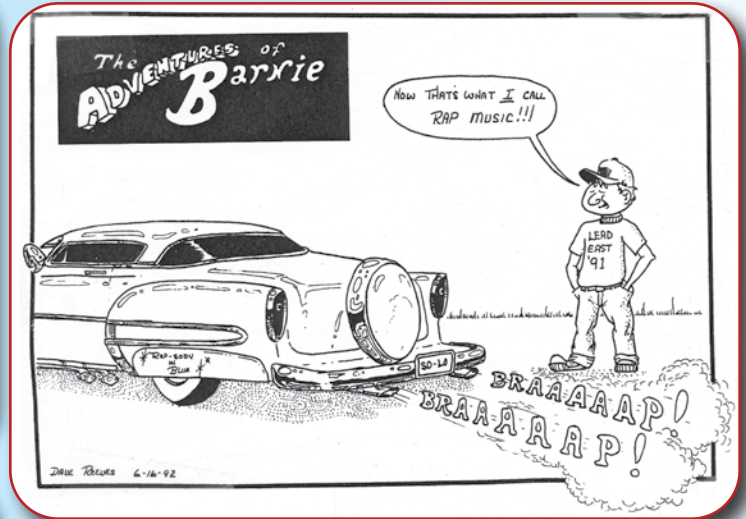

## DUAL EXHAUST PIPES

Aluminized pipes with flanges, clamps, hangers, and glass pack mufflers. Pre-bent for installation. **Fits Williams Headers**



ORDER #2017-P

**\$425** set

\*Oversize Shipping

## GLASS PACK MUFFLERS

For that radical 50's sound. 29" overall length, 2" inlet and outlets.  
**Give your "Blue Flame Six" a rap!**



ORDER #2015 **\$89** pr.

## LINKAGE ROD

Correct linkage rod to use with headers. Ready to install.

1949-52 216 or 235

ORDER #2017-L

1953-54 235

ORDER #2017-A

**\$30<sup>00</sup>**





# MUFFLERS/EXHAUST PARTS

## MUFFLERS

These original replacement mufflers are the correct size and shape and are great for low-mileage cars if you just need to replace the muffler. Works great if you're looking for original size, placement and sound.



**1949-54  
CONVERTIBLE**

ORDER #2005  
**\$66<sup>00</sup>**



**1949-53 ALL  
(Except Conv.)**

ORDER #2003 **\$59<sup>00</sup>**



**1954 ALL  
(Except. Conv.)**

ORDER #2004 **\$80<sup>00</sup>**

## EXHAUST PARTS

### ORIGINAL STYLE TAIL PIPE HANGER

ORDER #2002

**\$45<sup>00</sup>**



### MUFFLER/ EXHAUST CLAMP

Correct size  
for your  
1953-54 exhaust system.

ORDER #2009

**\$5<sup>00</sup>** ea.



### HEAT RISER SPRING



ORDER #1372

**\$30** ea.

### EXHAUST MANIFOLD NUTS (Brass)



ORDER #2000

**\$7<sup>00</sup>**

### UNIVERSAL TAILPIPE HANGER

With rubber vibration damper,  
fits tailpipe shape nicely.

ORDER #2008

**\$14<sup>00</sup>**



### EXHAUST DONUT 2" ORDER #2001 1-7/8" ORDER #2009

**\$6<sup>00</sup>** ea.



### EXHAUST PIPE HANGER

Use to support exhaust system by attaching  
to muffler clamp in center of car.

(Muffler clamp not included.)

ORDER #2007

**\$13<sup>00</sup>**



*William B  
Ohio*

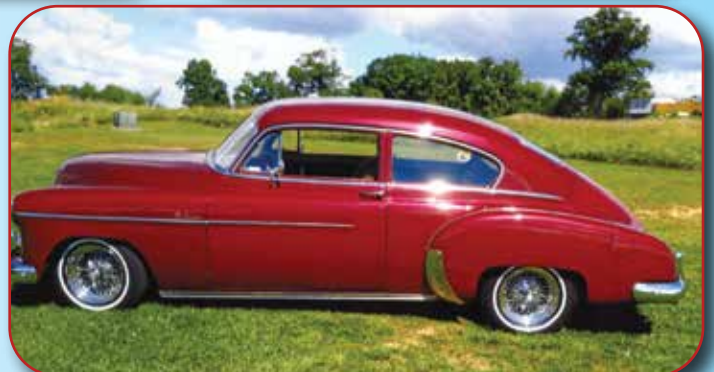

# 1949-52 METAL PANELS

## 1949-52 UNDER BATTERY AIR DUCT



Order #6484 **\$40<sup>00</sup>**

### COMPLAINT

#### BOX



Please write legibly.

## 1949-52 SPARE TIRE WELL



Yes — This is the section of the trunk that the spare tire sets in. Excellent heavy gauge metal reproduction with 1" lip on top for easy installation.

Order #692 **\$189<sup>00</sup>**

## 1949-52 FLEX-EDGE STRIPS

Ideal for repairing wheel openings.

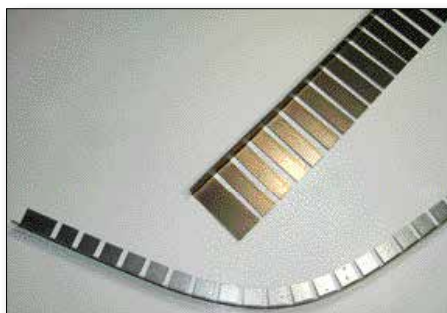

3' x 3" with 3/4" lip. **\$20** ea.  
Order #685

3' x 3/4" with 3/4" lip. **\$15** ea.  
Order #686



## 1949-52 SHEET STEEL

9" x 48"

18 Ga. Steel

Works well on bigger repair areas.

Order #687

**\$30<sup>00</sup>** ea.

## 1953-54 WHEEL WELL ACCESS RUBBER PLUG

Located at front of rear wheel well. Fits all cars.

Requires 2 per car.

ORDER #601-19

**\$15<sup>00</sup>** pr.



## GAS TANK BRACE

Sold for 1949-52.

Great replacement for rusty parts.



(1953-54 Pictured)

1949-52 DRIVER SIDE ORDER #7107-49L  
1949-52 PASS. SIDE ORDER #7107-49R

**\$60<sup>00</sup>** Ea.



Buddy M  
Maryland



# 1949-52 FLOOR PANS

## 1949-52 FLOOR PAN / TRUNK FLOOR PLUG

Fits 1/2" hole.

ORDER #601-15

**\$3<sup>00</sup>** ea.



## 1949-52 REAR FLOOR PANS

Right (Pass) Side

Order #693R

Left (Driver) Side  
Order #693L

**\$125** ea.

Replaces those rusty or mostly missing floor pans. These panels are slightly oversize and must be trimmed for proper fit.

Approx. 28 x 24



## 1949-52 FLOOR PAN PLUG

Fits 3/4" hole.

ORDER #4601-11

**\$3<sup>00</sup>** ea.



## 1949-52 FRONT FLOOR PANS

Excellent new floor replacement.

Sure cuts down on the noise and air coming in.

Driver Side Order #694L  
Passenger Side Order #694R

**\$135** ea.

Approx. 24 x 20



## 1949-52 REAR FLOOR PANS

TOP QUALITY 18 GAUGE STEEL

Fits all body styles. Starts a few inches under rear seat and goes forward to just past the back part of the front seat. Extends from rocker panel to rocker panel.

Includes rear part of transmission tunnel.

Driver Side

Order #4664L

Passenger Side

Order #4664R

**\$228** ea.



## 1949-52 FRONT FLOOR PANS

BEST QUALITY 18 GAUGE STEEL

Fits all body styles. From bottom of toe board and extends rearward to about the rear of the front seat. Extends from transmission tunnel to rocker panel.

Driver Side Order #4665L  
Passenger Side Order #4665R

**\$217** ea.



## 1953-54 FRONT FLOOR PANS

HIGH QUALITY DIE STAMPED 18 GAUGE STEEL

Made in USA. Goes from bottom of toe board to just behind the front seat.

Driver Side

Order #533L

Passenger Side

Order #533R

**\$217** ea.



# TOE BOARDS

## 1949-52 FRONT FLOOR TOE BOARDS

The part of the floor that slants upward into firewall.

Very nice part! Approx. 24 x 9

Driver Side

Order #691L

Passenger Side

Order #691R

**\$115<sup>00</sup>** ea.



## 1953-54 REAR FLOOR PANS

18 GAUGE STEEL

Another top quality panel with all original shapes and curves. Extends from rocker panel to rocker panel

Driver Side

Order #559L

Passenger Side

Order #4559R

**\$228** ea.



## 1949-52 TOE BOARDS

Fits all body styles. Extends from trans. hump to inner kick panel.

Driver Side Order #4663L  
Passenger Side Order #4663R

**\$148<sup>00</sup>** ea.



# 1949-52 METAL BODY PANELS

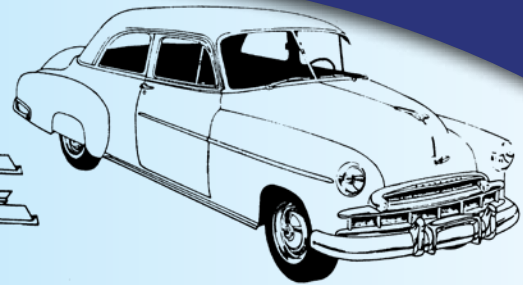
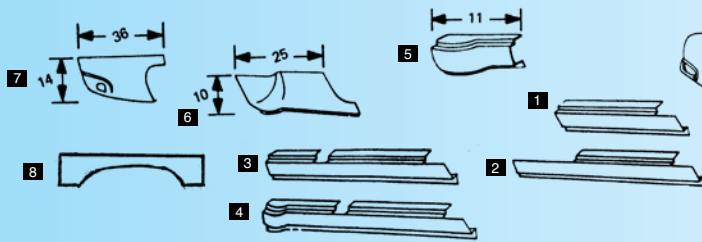

## 1 1949-52 2-DOOR ROCKER PANEL

(DR. SIDE) ORDER #4690L  
(PASS. SIDE) ORDER #4690R

CALL FOR  
AVAILABILITY



## 5 1949-52 ROCKER EXTENSION

Fits all models. 11" long.

(DR. SIDE) ORDER #4689L  
(PASS. SIDE) ORDER #4689R

CALL FOR  
AVAILABILITY



## 1949-52 INNER ROCKER PANEL (REPAIR PANEL)

Repair panel (in correct shape) for  
repairing inner rocker panels.  
3 ft. long.

Order **\$35**  
#4683



## 2 1949-52 2-DOOR ROCKER PANEL WITH EXTENSION

(DR. SIDE)  
ORDER #4695L  
(PASS. SIDE)  
ORDER #4695R

CALL FOR  
AVAILABILITY



## 7 1949-52 REAR FENDER REAR SECTION PANEL

(14" tall, 36" long)

(DR. SIDE) ORDER #4699L  
(PASS. SIDE) ORDER #4699R

CALL FOR  
AVAILABILITY



## 1949-52 UNDER DECK LID REPAIR PANEL

Metal panel to repair the gutter area  
where the rear gravel pan attaches  
to body of car under the deck lid.  
Requires both left and right repair  
panels to do entire rear of car.

1949-50

(DR. SIDE) ORDER #4681L  
(PASS. SIDE) ORDER #4681R

1951-52

(DR. SIDE) ORDER #4682L  
(PASS. SIDE)  
ORDER #4682R

**\$35** ea.



## 3 1949-52 4-DOOR ROCKER PANEL

(DR. SIDE) ORDER #4696L  
(PASS. SIDE) ORDER #4696R

CALL FOR  
AVAILABILITY

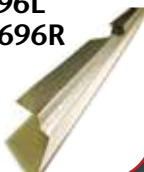

## 4 1949-52 4-DOOR ROCKER PANEL WITH EXTENSION

(DR. SIDE)  
ORDER #4688L  
(PASS. SIDE)  
ORDER #4688R

CALL FOR  
AVAILABILITY



## 1949-50 WHEEL OPENING REPAIR PANEL

(DR. SIDE) ORDER #4698L  
(PASS. SIDE) ORDER #4698R

## 1951-52 WHEEL OPENING REPAIR PANEL

(DR. SIDE) ORDER #4684L  
(PASS. SIDE) ORDER #4684R

**\$40<sup>00</sup>** ea.

Metal panel to repair rusty wheel openings.  
This is not one of those "universal" repair  
panels. Has correct shape so your 1949-52  
fendershirts fit to a "T".



## 1949-52 CHEV SEDAN DELIVERY LOWER FRONT QUARTER PANEL

(DR. SIDE) ORDER #4653L  
(PASS. SIDE) ORDER #4653R

**\$299<sup>00</sup>** pr.

2-piece set  
as shown.

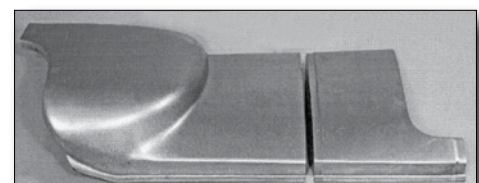



# 1949-52 BRACES/TRANSMISSION TUNNEL

## 1949-52 DOOR POST BRACE

Fits all body styles.

(DR. SIDE)  
ORDER #4667L

(PASS. SIDE)  
ORDER #4667R

**\$102** ea.

Fits 1949-52 Cars.



## 1949-52 FRONT FLOOR BRACE

Fits all body styles.

(DR. SIDE) ORDER #4666FL

(PASS. SIDE) ORDER #4666FR

**\$102<sup>00</sup>** ea.



## 1949-52 CENTER FLOOR BRACE

Fits all body styles.



(DR. SIDE) ORDER #4666CL  
(PASS. SIDE) ORDER #4666CR

**\$102<sup>00</sup>** ea.

## 1949-52 REAR TRUNK FLOOR BRACE

Fits all body styles. Extends from fender to fender and includes body bracket.



ORDER #4666T

**\$136<sup>00</sup>** ea.

## 1949-54 TRANSMISSION TUNNEL

Fits all models.



ORDER #4668

**\$217** ea.

# 1949-52 DOOR BOTTOMS

Includes inner die stamped section and outer section.

Fits Sedan and Coupe.



(DR. SIDE)  
ORDER  
#4675

(PASS. SIDE)  
ORDER  
#4674

**\$263<sup>00</sup>** ea.

## 1949-50 FRONT SPLASH PAN

Excellent reproduction!  
Fits all models.



ORDER #1944

**\$279** ea.

## 1949-52 REAR GRAVEL PANS

1949-50 fits all  
models except  
Station Wagon.



ORDER #4654

**\$267<sup>00</sup>**



1951-52 fits all  
models except  
Station Wagon and  
Sedan Delivery.

ORDER #4654-51

**\$267<sup>00</sup>**

# 1949-52 BODY PANELS

## 1949-52 LOWER FRONT QUARTER PANEL

Fits all 2-dr. body styles. From rear door post to center of rear wheel opening.

(DR. SIDE) ORDER #4661L

(PASS. SIDE) ORDER #4661R

**\$240<sup>00</sup>** ea.



## 1949-52 LOWER REAR QUARTER PANEL

Fits all 2- and 4-dr. body styles. Extends from center of wheel opening to rear bumper.

(1949-50 DR. SIDE) ORDER #4659L

(1949-50 PASS. SIDE) ORDER #4659R

(1951-52 DR. SIDE) ORDER #4660L

(1951-52 PASS. SIDE) ORDER #4660R

**\$240** ea.

NOTE: To use fender skirts with 1951-52 panels, you must use 1949-50 skirts.



## 1949-52 LOWER FRONT FENDER PANEL

Fits all models.  
Installs behind front tire.  
(PASS. SIDE) ORDER #4687R  
(DR. SIDE) ORDER #4687L

**\$90<sup>00</sup>** ea.



# 1949-52 TAIL PANS/TRUNK FLOOR REAR SECTION

## 1949-50 COUPE/SEDAN TAIL PAN

Fits 2-dr., 4-dr., conv., and hardtop body styles.  
Fits from fender seam to fender seam.

ORDER #4670

**\$335<sup>00</sup>**



## 1949-50 FLEETLINE TAIL PAN

Fits all 2- and 4-dr. models. Fits from fender seam to fender seam.

ORDER #4669

**\$335<sup>00</sup>**



## 1951-52 COUPE/SEDAN TAIL PAN

Fits 2-dr., 4-dr., conv., and hardtop from fender seam to fender seam.

ORDER #4662

**\$297<sup>00</sup>**



## 1951-52 FLEETLINE TAIL PAN

Fits all 2- and 4-dr. body styles from fender seam to fender seam.

ORDER #4672

**\$297<sup>00</sup>**



## 1949-52 SEDAN DELIVERY TAIL PAN

Goes under the rear cargo door and extends from fender to fender.

ORDER #4680

**\$349<sup>00</sup>**



## 1949-52 TRUNK FLOOR REAR SECTION

Starts at bottom of tail pan and extends forward about 8".  
Fits all 2- and 4-door body styles.

ORDER #4671

**\$194<sup>00</sup>** ea.





# FLOOR BRACES

## 1949-52 FLOOR BRACES

### ONE PIECE FLOOR BRACES

1949-52 One-Piece Front Floor Brace

ORDER #4655F **\$184<sup>00</sup>**

1949-52 One-Piece Center Floor Brace

ORDER #4655C **\$172<sup>00</sup>**

1949-52 One-Piece Rear Floor Brace

ORDER #4655R **\$184<sup>00</sup>**



## 1953-54 FLOOR BRACES

### 1953-54 FRONT FLOOR BRACE

ORDER #1621  
**\$184<sup>00</sup>** ea



### 1953-54 CENTER FLOOR BRACE

ORDER #1622  
**\$184<sup>00</sup>** ea



### 1953 REAR FLOOR BRACE

ORDER #1623  
**\$230<sup>00</sup>** ea



### 1953-54 CHEVY FLOOR BRACES - SHORT BRACES

First, second and third rows are now available. Fourth row should be available soon. Approximately 14" long.

#### 1st Row

(PASS. SIDE) ORDER #688-1R  
(DR. SIDE) ORDER #688-1L



#### 2nd Row

(PASS. SIDE) ORDER #688-2R  
(DR. SIDE) ORDER #688-2L



#### 3rd Row

(PASS. SIDE) ORDER #688-3R  
(DR. SIDE) ORDER #688-3L



#### 4th Row

(PASS. SIDE) ORDER #688-4R  
(DR. SIDE) ORDER #688-4L



**\$102<sup>00</sup>** ea.

# 1953-54 METAL BODY PANELS

CALL FOR AVAILABILITY



## 1 1953-54 2-DOOR OUTER ROCKER PANEL WITH EXTENSION

Replace your rusty rocker panels with this fabricated replacement that extends to rear fender flare.

DRIVER SIDE  
PASS. SIDE

ORDER #695L  
ORDER #695R

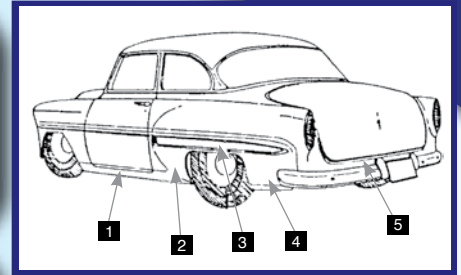

## 1953-54 2-DOOR OUTER ROCKER PANEL

Excellent reproduction rocker panel stamped out just like original. (No extension)

DRIVER SIDE ORDER #690L  
PASS. SIDE ORDER #690R



## 2 1953-54 2-DOOR REAR QUARTER PANEL FRONT

Replaces metal in front of rear tire under gravel shield.

DRIVER SIDE  
ORDER #697L

PASS. SIDE  
ORDER #697R



**\$35<sup>00</sup>** ea.



## 1953-54 4-DOOR SEDAN ROCKER PANEL

Fits 4 door Sedans that need rocker panel replacement. Extends to back edge of rear door.

DRIVER SIDE ORDER #696L  
PASS. SIDE ORDER #696R



## 1953-54 2-DOOR INNER ROCKER PANEL

Reproductions of metal repair panels do not get any nicer than this. Stamped and cut like originals.

DRIVER SIDE ORDER #689L  
PASS. SIDE ORDER #689R

## 3 1953-54 WHEEL OPENING REPAIR PANEL

Metal panel to repair rusty wheel openings. This is not one of those "universal" repair panels. It has correct shape so your 1953/54 fenderskirts fit to a "T."

DRIVER SIDE  
ORDER #698L  
PASS. SIDE  
ORDER #698R



**\$40** ea.

4



## 1953-54 REAR FENDER REAR SECTION PANEL

Extends around rear to taillight seam.

DRIVER SIDE ORDER #699L  
PASS. SIDE ORDER #699R

3

5

## 1953-54 UNDER DECK LID REPAIR PANEL

Metal panel to repair the gutter area where rear gravel pan attaches to body of car, under the deck lid. Requires both left and right repair panels to do entire rear of car.



DRIVER SIDE  
ORDER #684L

PASS. SIDE  
ORDER #684R

**\$24<sup>00</sup>** ea.

## 1953-54 LOWER FRONT QUARTER PANEL

Extends from door jamb to about half way through wheel well opening and extends about 4" over top of wheel well.

DRIVER SIDE ORDER #682L  
PASS. SIDE ORDER #682R

**\$240<sup>00</sup>** ea.



## 1953-54 REAR FENDER REAR SECTION

Fits behind tire.

DRIVER SIDE ORDER #683L  
PASS. SIDE ORDER #683R

**\$240<sup>00</sup>** ea.





# 1953-54 METAL PANELS



## 1953-54 TRUNK FLOOR

Trunk floor complete.  
Includes placement instructions.

ORDER #661

**\$320<sup>00</sup>**

## 1953-54 DOOR BOTTOMS

Fits all 1953-54 2 Dr. Sedans.



(DR. SIDE) ORDER #660L  
(PASS. SIDE) ORDER #660R

**\$263<sup>00</sup>** ea

## 1953-54 TRUNK FLOOR EXTENSION

Covers last 8" of trunk floor  
from side to side.

ORDER #680

**\$182<sup>00</sup>**



## 1953-54 FRONT FENDER BRACE



Fits all models.  
Fits behind the tire.

(DR. SIDE)  
ORDER #681L

(PASS. SIDE)  
ORDER #681R

**\$56<sup>00</sup>** ea

## 1953 FRONT SPLASH PAN

Excellent reproduction! Fits all models.

ORDER #1945

**\$247<sup>00</sup>** ea



## 1953-54 LOWER FRONT FENDER PANEL BEHIND FRONT TIRE

Fits all 2-dr. cars.

Will fit Sedan Delivery, 4-dr. Station Wagon with some modification.

(PASS. SIDE) ORDER #528R

(DR. SIDE) ORDER #528L

**\$102<sup>00</sup>** ea



## 1953-54 TAILPAN

Fits all models except Station Wagons.

Full width fender to fender seam.

18 gauge die stamped with all OEM shapes and curves.

ORDER #677

**\$316<sup>00</sup>**



## 1953-54 REAR GRAVEL PAN

ORDER #678

**\$274<sup>00</sup>** ea



# 1949-54 METAL BODY PANELS

## 1953-54 INTERIOR REAR QUARTER PANEL

DR. SIDE

ORDER #663-L

PASS. SIDE

ORDER #663-R

**\$189<sup>00</sup>** ea.



## 1953-54 SEDAN DELIVERY CARGO FLOOR SUPPORT BRACKET KIT

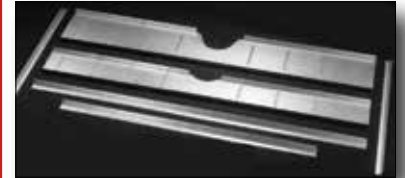

ORDER #679

**\$159<sup>00</sup>**

## 1953-54 COMPLETE TRUNK FLOOR (1 pc.)

ORDER #665

**\$825<sup>00</sup>**

DROP SHIP **only \$200.00**

Total Cost **\$919<sup>00</sup>**



## 1953-54 REAR TRUNK FLOOR BRACE

All brackets already attached.  
Ready to install. Painted black.

ORDER #644

**\$140<sup>00</sup>**



1949-52  
Top View

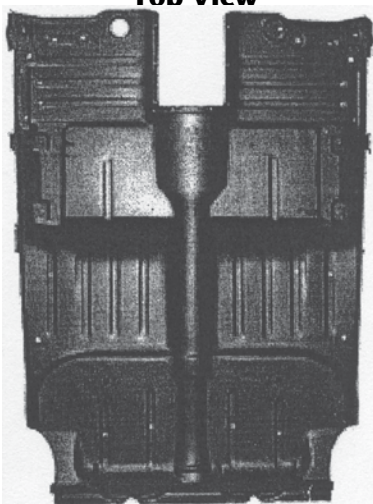

## 1949-54 FULL INTERIOR FLOOR

Complete and ready to install.

1949-52 ORDER #665-1

1953-54 ORDER #665-2

**\$1299<sup>00</sup>\***

Shipping extra.

**\*Ship by truck only.**

To Business \$250.00

To Residence \$300.00

1953-54  
Top View

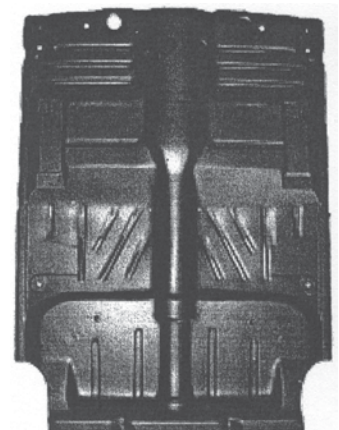



# 1953-54 METAL PANELS

## 1953-54 FRONT FLOOR PANS

**HIGH QUALITY DIE STAMPED 18 GAUGE STEEL**

Made in USA. Goes from bottom of toe board to just behind the front seat.



**Driver Side**  
Order #533L  
**Passenger Side**  
Order #533R

**\$189** ea.

## 1953-54 REAR FLOOR PANS

**Right (Pass) Side**

Order #693R

**Left (Driver) Side**

Order #693L

**\$109** ea.

Replaces those rusty or mostly missing floor pans. These panels are slightly oversize and must be trimmed for proper fit.

Approx. 28 x 24



## 1953-54 REAR FLOOR PANS

**18 GAUGE STEEL**

Another top quality panel with all original shapes and curves. Extends from rocker panel to rocker panel.



**Driver Side**  
Order #559L  
**Passenger Side**  
Order #559R

**\$199** ea.

## 1953-54 FRONT FLOOR PANS

Excellent new floor replacement.

Sure cuts down on the noise and air coming in.

**Driver Side** Order #694L

**Passenger Side** Order #694R

**\$119** ea.

Approx. 24 x 20



## GAS TANK BRACE

Sold for 1953-54.

Great replacement for rusty parts.



(1953-54 Pictured)

1953-54 DRIVER SIDE ORDER #7107-53L

1953-54 PASS. SIDE ORDER #7107-53R

**\$60<sup>00</sup>** Ea.

## 1953-54 FRONT FLOOR TOE BOARDS

The part of the floor that slants upward into firewall.

Very nice part! Approx. 24 x 9

**Driver Side**  
Order #691L  
**Passenger Side**  
Order #691R

**\$99<sup>00</sup>** ea.



## 1949-54 HOOD SPRING TOOL

Using this tool is the best and easiest way to remove old hood springs and install new ones. Comes with instruction sheet.



ORDER #1357

**\$49<sup>00</sup>** pr.

## 1949-52 INSIDE DOOR HANDLE REMOVAL PLIER

Removes horseshoe-shaped handle clip. Makes handle removal a snap.



ORDER #4713

**\$23<sup>00</sup>**

## 1949-54 HOG RING PLIERS

Straight Nose Spring Grip, holds rings in place for fast work.



ORDER #767

**\$36<sup>00</sup>**

## 1949-54 TERMINAL CRIMPER/BOLT CUTTER

Crimps non-insulated terminals, the type found originally on your car.

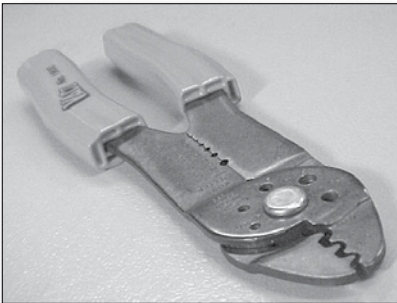

ORDER #2401

**\$39<sup>00</sup>**

## 1949-54 HOG RINGS

You need these to install that new interior. Approx. 250 rings.



ORDER #768

**\$12<sup>00</sup>**

## 1949-54 HEADLINER TOOL

Pushes headlining in channel above doors. Easy to use around curves and near corners.



ORDER #770

**\$20<sup>00</sup>**

## 1953-54 INSIDE DOOR HANDLE REMOVAL TOOL

Removes horseshoe-shaped handle clip. Makes handle removal a snap. Fits many other makes also.



ORDER #713

**\$15** ea.

## HOG RING CUTTER

ORDER #769

**\$35<sup>00</sup>**



## CLUTCH HEAD SCREWDRIVER

Magnetic screw driver handle with a 1/4" and a 5/32" clutch head inserts. Great for use on firewall.

ORDER #788

**\$29**





# LOCKS/KEYS/RETAINERS/IGNITION SWITCH

## 1953-54 REPLACEMENT IGNITION SWITCH RETAINING NUT



Not exact repro but works. Holds plastic bezel to your dash and ignition switch.

ORDER #792

**\$19<sup>00</sup>**

## 1953-54 IGNITION BEZEL

Exact reproduction.  
Clear plastic with black letters.

ORDER #731

**\$35<sup>00</sup>**



## 1953-54 ORIGINAL STYLE TRUNK LOCK



Replace that missing or broken lock with one that works. Does not include lock rod.

ORDER #1132

**\$49<sup>00</sup>**

## REPLACEMENT IGNITION CYLINDER WITH KEYS

This will replace your worn ignition cylinder.

ORDER #793

**\$25<sup>00</sup>**



## 1949-54 KEY BLANKS

Original style key blanks to have cut for your locks.



## 1953-54 TRUNK LOCK RETAINER



ORDER #1133

**\$12<sup>00</sup>**

## 1953-54 REPLACEMENT TRUNK LOCK



Economy model lock that uses late model style key

ORDER #1134

**\$39<sup>00</sup>**

## PRIMARY KEY SQUARE HEAD

ORDER #1141

**\$7<sup>00</sup>** ea.

## SECONDARY KEY ROUND SHAPED

ORDER #1142

**\$7<sup>00</sup>** ea.

## 1951-52 IGNITION SWITCH



ORDER #4761

**\$60<sup>00</sup>**

## 1949-50 IGNITION SWITCH



ORDER #4760

**\$60<sup>00</sup>**

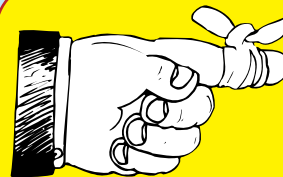

Whether by phone, fax, mail or email...

**PLEASE  
BE SURE TO USE  
PART NUMBERS  
WHEN ORDERING.**

*This is the only way we can be sure of what you want and avoid costly mistakes.*

*Don't forget to check out our website for used parts  
[www.nationalchevyassoc.com](http://www.nationalchevyassoc.com)  
While you're at it, check out the newsletter in full color.*



# NEW PANELS

## 1953-54 INTERIOR REAR QUARTER PANEL

DR. SIDE  
ORDER #663-L

PASS. SIDE  
ORDER #663-R

**\$169<sup>00</sup>** ea.



## 1953-54 COMPLETE TRUNK FLOOR (1 pc.)

ORDER #665

**\$719<sup>00</sup>**

DROP SHIP **only \$200.00**

Total Cost **\$919<sup>00</sup>**



## 1953-54 REAR TRUNK FLOOR BRACE

All brackets already attached.  
Ready to install. Painted black.

ORDER #644

**\$140<sup>00</sup>**



## 1949-54 SEDAN DELIVERY CARGO FLOOR SUPPORT BRACKET KIT

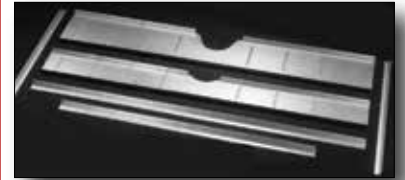

ORDER #679

**\$159<sup>00</sup>**

## 1949-52 Top View

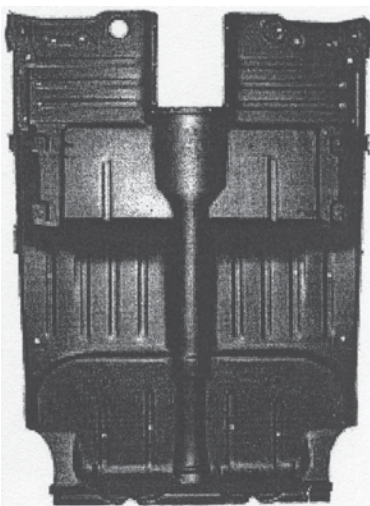

## 1949-54 FULL INTERIOR FLOOR

Complete and ready to install.

1949-52 ORDER #665-1

1953-54 ORDER #665-2

**\$999<sup>00</sup>\***

Shipping extra.

**\*Ship by truck only.**

To Business \$150.00

To Residence \$200.00

## 1953-54 Top View

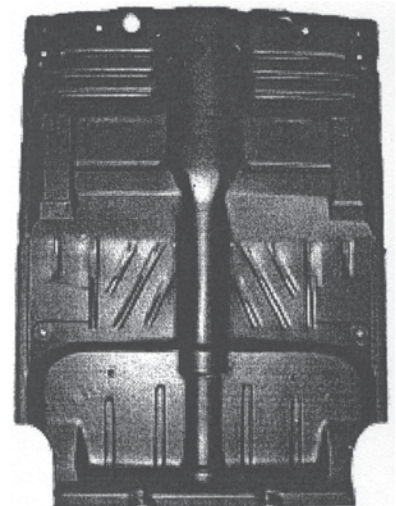



# TOOLS

## 1949-54 HOOD SPRING TOOL

Using this tool is the best and easiest way to remove old hood springs and install new ones. Comes with instruction sheet.



ORDER #1357

**\$49<sup>00</sup>** pr.

## 1949-52 INSIDE DOOR HANDLE REMOVAL PLIER

Removes horseshoe-shaped handle clip. Makes handle removal a snap.



ORDER #4713

**\$23<sup>00</sup>**

## 1949-54 TERMINAL CRIMPER/BOLT CUTTER

Crimps non-insulated terminals, the type found originally on your car.

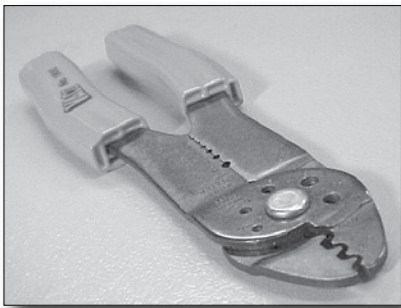

ORDER #2401

**\$39<sup>00</sup>**

## 1949-54 HOG RINGS

You need these to install that new interior. Approx. 250 rings.



ORDER #768

**\$12<sup>00</sup>**

## 1949-54 HOG RING PLIERS

Straight Nose Spring Grip, holds rings in place for fast work.



ORDER #767

**\$36<sup>00</sup>**

## 1949-54 HEADLINER TOOL

Pushes headlining in channel above doors. Easy to use around curves and near corners.



ORDER #770

**\$20<sup>00</sup>**

## 1953-54 INSIDE DOOR HANDLE REMOVAL TOOL

Removes horseshoe-shaped handle clip. Makes handle removal a snap. Fits many other makes also.



ORDER #713

**\$15** ea.

## HOG RING CUTTER

ORDER #769

**\$35<sup>00</sup>**



## CLUTCH HEAD SCREWDRIVER

Magnetic screw driver handle with a 1/4" and a 5/32" clutch head inserts. Great for use on firewall.

ORDER #788

**\$29**



# LOCKS/KEYS/RETAINERS/IGNITION SWITCH

## 1953-54 REPLACEMENT IGNITION SWITCH RETAINING NUT



Not exact repro but works. Holds plastic bezel to your dash and ignition switch.

ORDER #792

**\$19<sup>00</sup>**

## 1953-54 IGNITION BEZEL

Exact reproduction.  
Clear plastic with black letters.

ORDER #731

**\$35<sup>00</sup>**



## 1953-54 ORIGINAL STYLE TRUNK LOCK



Replace that missing or broken lock with one that works. Does not include lock rod.

ORDER #1132

**\$49<sup>00</sup>**

## REPLACEMENT IGNITION CYLINDER WITH KEYS

This will replace your worn ignition cylinder.

ORDER #793

**\$25<sup>00</sup>**



## 1949-54 KEY BLANKS

Original style key blanks to have cut for your locks.



## 1953-54 TRUNK LOCK RETAINER

ORDER #1133

**\$12<sup>00</sup>**



## 1953-54 REPLACEMENT TRUNK LOCK

Economy model lock that uses late model style key

ORDER #1134

**\$39<sup>00</sup>**



## PRIMARY KEY SQUARE HEAD

ORDER #1141

**\$7<sup>00</sup>** ea.

## SECONDARY KEY ROUND SHAPED

ORDER #1142

**\$7<sup>00</sup>** ea.

## 1951-52 IGNITION SWITCH



ORDER #4761

**\$60<sup>00</sup>**

## 1949-50 IGNITION SWITCH



ORDER #4760

**\$60<sup>00</sup>**

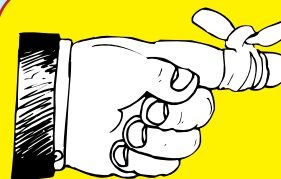

Whether by phone, fax, mail or email...

**PLEASE  
BE SURE TO USE  
PART NUMBERS  
WHEN ORDERING.**

*This is the only way we can be sure of what you want and avoid costly mistakes.*



*Don't forget to check out our website for used parts  
[www.nationalchevyassoc.com](http://www.nationalchevyassoc.com)  
While you're at it, check out the newsletter in full color.*



# INDEX

## ORDERING AND SHIPPING INFORMATION FOUND ON PAGE 4

### A

#### ACCELERATOR

Pedal .....	120
Pedal Cover .....	120
Pedal and Dimmer .....	
Switch Grommet .....	66
Shaft Seal Set .....	120
Accessory Fuse Holder .....	59
Accessory Installation Manual .....	
1949-52 .....	21
1953 .....	23
1954 .....	24
Accessory Vanity Mirror .....	41
Air Cleaner (Custom) .....	125
Air Cleaner (Custom) Filter .....	125
Alternator Bracket .....	140
Armrests .....	74
<b>ASHTRAY</b> .....	
Insert - HT/Conv. ....	61
Sliding Top - HT/Conv. ....	61

### B

#### BATTERY

Air Duct (Under Battery 1949-52) .....	154
Cables .....	128
Disconnect Switch .....	128
Hold Down Bolts .....	128
Retainer .....	128
Tender .....	128
Tray .....	128
BelAir Bloomers .....	17
Belt Moulding Clip Kits .....	43-47
Belt Weatherstrip .....	108
Blue Dot Lenses .....	31-34
Blue Dots .....	35
Body Repair Panels .....	154-162
Body to Bezel Gasket (Tail Light) .....	33, 34
Body to Frame Pads .....	148
Bow Drill Cloth .....	116

#### BRAKE

Adjustor Screw .....	129, 130
Adjustor Screw Spring .....	129, 130
Adjustor Hole Plug .....	129, 130
Bleeder Screw .....	129, 130
Drum .....	129, 130
Dual Braking System .....	132
Frame Clips .....	131

Hoses .....	133
Hose T Fitting .....	133
Hose Retaining Clip .....	133
Light Switch .....	129, 130
Lines (Stainless) .....	131
Pedal Pad .....	129, 130
Shoes .....	129, 130
Shoe Hold Down Spring Kit .....	129, 130
Return Springs .....	129, 130
Bullet Valve Stem Covers .....	39
Bull Nose Hood Strip .....	17
<b>BUMPER</b> .....	49, 50
Arm Grommet (1949-52 Rear) .....	49
Assembly Kits .....	49, 50
Bumper Bolt Kits .....	49, 50

### C

California Duster .....	16
California Water Blade .....	16
Car Cover .....	16
<b>CARBURETOR</b> .....	
Float .....	121
Gasket .....	121
Insulator Plate .....	121
Rebuild Kit .....	121

#### CARPET

Interior .....	68, 69
Trunk .....	98, 99
Carpet Adhesive .....	66, 97
Carpet Mats .....	66

#### CLUTCH

Assemblies .....	127
Clutch and Brake .....	
Pedal Stop Bumper .....	130
Pilot Bushing .....	126
Shaft Seal Set .....	130

#### CLUTCH HEAD

Screwdrivers .....	163
Coat Hooks .....	63
Coffee Mug .....	16
Coil (6 V) .....	125
Continental Kit .....	12, 13
Continental Kit Parts .....	13
Conversion Kit (6V to 12V) .....	140

#### CONVERTIBLE

Top .....	115
Top Operation Manual - 1954 .....	20, 24
Top Pads .....	115
Top Pins .....	115

#### CONVERTIBLE TOP WEATHERSTRIP

Roof Rail Weatherstrip .....	113, 114
Stops/Grommets .....	116
Top Corners .....	116
Top Header Seal .....	116

### D

#### DASH

Glass .....	61
Knobs (1949-52) .....	58
Script .....	61

#### DECALS

Engine .....	22, 27
--------------	--------

#### DOME LIGHT

Covers .....	63
Housing (Hardtop) .....	63
Rim (Sedan) .....	63
Switch .....	63
Switch Gasket .....	63
Door Edge Metal Strips .....	93

#### DOOR

Access Plug (Sedan) .....	111, 112
Bottoms (1949-52) .....	157
Bottoms (1953-54) .....	161
Check Link .....	94
Glass Roller Stops .....	113, 114
Grommets .....	94, 95

#### HANDLES

Inside .....	62
Outside .....	39
Retainers for Outside Handles .....	39
Handle Horseshoe Clip .....	62
Handle Lock Pads .....	39
Handle Removal Tool .....	62, 163
Handle Retainer Washer .....	62
Handle Shields .....	39
Handle Tension Spring .....	62
Hinge Pins .....	94, 95
Hinge Pin Bushing .....	94, 95
Lock Buttons .....	63
Lock Set (Exterior) .....	39
Molding Trim Strip .....	42
Panel Cardboard .....	92, 93
Panel Metal Edge Strips .....	93
Panel Nails .....	92
Sill Plates .....	70, 71
Striker Plate .....	95
Weatherstrip (All Models) .....	94, 95
Drive Shaft Bushing Seal Assembly .....	126

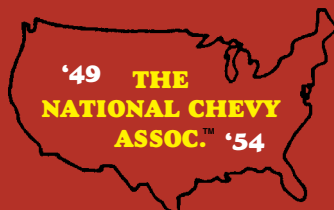

The National Chevy Association was formed in 1985 as a car club dedicated to the "pleasure, pride and preservation" of the '53 and '54 Chevrolet. Beginning February 2000, the National Chevy Association expanded to include the 1949-52 Chevrolets in the Association. We have developed a complete line of parts and accessories for the 1949-52 Chevs and encourage you to contact us for a fully illustrated catalog of 1949-52 Chevrolet parts, if you have one of these "forgotten classics."

Drive Shaft Bushing	
Installation Tool.....	126
Dual Exhaust (V-8).....	152
Dummy Spotlights.....	17

## E

Electric Fan (6V/12V).....	135
Electronic Ignition.....	125
Emblems (Hood and Trunk).....	36-37
Emblem with Bezel (1954).....	36

### EMERGENCY BRAKE

Bar Spring.....	132
Cable.....	132
Cable Boot.....	132
Cable and Bracket Kit.....	132
Cable Bracket.....	132
Cable Seal.....	132
Handles.....	129, 130
Engine Gaskets.....	122, 123
Engine Paint.....	27, 124

### EXHAUST

Chrome Tips.....	151
Deflector.....	151
Donut.....	153
Manifold Gaskets.....	122
Manifold Nuts.....	153
Mufflers.....	153
System (Complete).....	151
System (Dual).....	152

## F

Fan, Electric.....	135
Fan Belt.....	136

### FENDER SKIRTS

Brackets.....	55
Rubber.....	55
Skirts.....	55

### FIREWALL INSULATION

Clips.....	146
Pad.....	145, 146
Firewall Grommets.....	145, 146
Flipper Bar Seal (Hardtop).....	113
Floor Mats.....	66
Floor Pans.....	155
Floor Shift Kit (3-Speed).....	127
Front Clip Assembly Kit.....	148

### FRONT FENDER

Anti-Squeak Kits.....	148
Fender to Door Seal.....	94
Gravel Shields.....	38
Markers.....	38
Molding Trim Strip.....	42
U Seal.....	148
Front Inner Wheel Bearing.....	128
Front License Pocket Guard (1949-50) ..	49
Front Outer Wheel Bearing.....	128
Front Splash Pan (1949-50).....	157
Front Splash Pan (1953).....	159

Front Splash Pan Plug (1949-52).....	49
Fuel Filter.....	118
Fuel Gauge.....	120
Fuel Gauge Reducer.....	141
Fuel Lines.....	119
Fuel Line Frame Clip.....	119
Fuel Pumps.....	120
Fuel Pump to Engine Block Gasket.....	120
Fuel Tank Neck Grommet.....	119
Full Trunk Floor (1949-52).....	162
Full Trunk Floor (1953-54).....	162
Fuzzy Dice.....	74

## G

Garage/Shop Decals.....	Inside Back Cover
-------------------------	-------------------

### GAS

Cap.....	118, 119
Door Grommets.....	121
Door Guard (Accessory).....	120
Filter.....	120
Line Frame Clips.....	119
Lines.....	119
Tank.....	118, 119
Tank Float.....	119
Tank Neck Grommet	
(Sed. Del., Sta. Wagon).....	120
Tank Sending Unit (All Models) ....	118
*Tank Sending Unit	
Gasket/Screws.....	118
Tank Braces.....	154
Tank Straps.....	118, 119

### GASKETS

Engine.....	122, 123
Rear End.....	122
Sealer.....	122, 123
Garnish Molding Screw Kit.....	66
Gear Indicator Needle (Powerglide).....	61
Gear Shift Collar.....	56
Generator Rebuild Kit.....	125
Gift Certificate.....	5

### GLASS CHANNEL

Windshield, Rear Window.....	106, 107
Glass - Side Windows.....	102-104

### GLASS SETTING CHANNEL RUBBER

Hardtop/Conv.....	113, 114
Sedan.....	111, 112
Glass Tracks.....	109, 110
Glass - Window Frame Set Channel	
(HT/Conv).....	113, 114

Glove Box.....	60
Glove Box Grommet.....	60
Glove Box Lock.....	60

### GRAVEL SHIELDS (REAR)

1953-54 2-dr. BelAir Models.....	42
Grill Assembly Kits.....	48
Grill Bars (1949, 1953, 1954).....	53
Grill Installation Kits.....	48
Grill Teeth 1953.....	53
Grill Teeth 1954.....	53

## H

Hats.....	5
Headers.....	152

### HEADLIGHT

Bezels.....	147
Bezel Seal.....	147
Bucket Gasket.....	147
Bucket Grommet.....	147
Bucket Wire Harness.....	136
Bulb.....	141
Bulb Retainer Ring.....	147
Covers (Custom).....	15
Dimmer Switch.....	141
Housing Screw Set.....	147
Junction Block.....	141
Switch (6V, 12V).....	141
Switch Knobs (1949-52).....	58
Visors (Custom).....	15

### HEADLINER

Hardtop.....	65
Sedan.....	65
Headliner Installation Tool.....	64
Heat Plate (Headers).....	152
Heat Riser Springs.....	153
Heater Control Valve (Replacement) ....	136
Heater Control Valve Seal.....	136
Heater Hose.....	136
Heater Knobs (1951-52).....	58
Hog Rings.....	163
Hog Ring Cutter.....	163
Hog Ring Pliers.....	163
Hood Birds.....	36

### HOOD

Bolts.....	149
Brace Seal.....	149
Grommet Kit.....	149
Springs.....	149
Spring Removal Tool.....	149

### HORN BUTTONS

Contact Insulating Sleeve.....	57
Contact Spring.....	57
Mounting Screw Insulators.....	57
Relay.....	57
Ring.....	56, 57
Ring Spacer (1949-52).....	57

## I

### IGNITION

Bezel.....	164
Cylinder.....	164
Switch Retaining Nut.....	164
Intake Manifold Sleeves.....	123

### INTERIORS

Custom Interiors.....	76-89
-----------------------	-------

## J

Jack Tag 1953, 1954.....	99
Junction Blocks - Headlight.....	141



# INDEX

## K

Key Blanks .....	164
Key Ring .....	16
Kick Panels.....	72, 73

## L

Lake Pipe Clamps.....	151
Lake Pipes.....	151
Lamp Plug ('54 Tail Light).....	35
Leaf Springs.....	144

### LICENSE PLATE

Bracket .....	51
Fasteners .....	54
Frames.....	54
Light Bulbs 6V .....	141

### LITERATURE

1949-54 .....	18-28
---------------	-------

### LOWER WINDOW STOP IN DOOR

Hardtop/Conv. ....	113, 114
Sedan.....	111, 112
Lower Rear Quarter Window Stop (HT/Conv) .....	113, 114
Lowering Block Kit.....	144
Lug Nuts.....	39

## M

<b>MASTER CYLINDER</b> .....	133
Braking System (Dual) .....	132
Cover.....	133
Rebuild Kit.....	133
Remote Filler Conversion Kit (Stock) .....	132
Shaft Lock Pin.....	133

Metal Panels (Inside, Outside).....	154-162
Metal Signs.....	29, 30

### MIRRORS

Accessory Day/Night .....	41
Brackets ('53-43 HT).....	41
Inside Rear View .....	41
Outside .....	40
Molding Clip Kits.....	43-47
Motor Mounts .....	122
Mufflers .....	153
Muffler Clamps.....	153

## O

Oil Cap .....	124
Oil Filter.....	124
Oil Lines .....	124
Outside Sunvisor.....	115
Outside Sunvisor Center Bracket.....	115
Owners Manual - 1949-1954.....	18, 19, 23, 24

## P

Package Shelf.....	73
Paint Divider Clips, BelAir.....	42

### PAINT

Engine.....	27, 124
Trim .....	27

### PARK LIGHT

Assembly (1951).....	51
Bezel (1954).....	52
Gaskets - 1949-1954 .....	51, 52
Housing - 1953-1954 .....	52
Lens - 1949-1954 .....	51, 52
Pictures .....	20, 28
Pilot Bushing .....	126
Power Brake Pedal Pad.....	130

## Q

Quarter Window Seals (HT/Conv).....	113, 114
Quarter Window Stop (HT/Conv) .....	113, 114

## R

<b>RADIATOR</b> .....	135
Cap .....	135
Hoses .....	135
Overflow Canister.....	136
Petcock.....	135
Saddle Bolts.....	135
Saddle Cushions & Shims .....	135

<b>RADIO (6V or 12V)</b> .....	59
Antenna .....	59
Glass.....	60
Vibrator Tube .....	59

Rear Gravel Pans (1949-52) .....	157
Rear Gravel Pans (1953-54) .....	161
Rear Gravel Pan Installation Kit.....	99
Repair Panels (Metal) .....	154-162

### ROCKER

Molding Clips.....	42
Molding Trim Strips.....	42
Panels.....	156, 160
Roof Rail Weatherstrip (Conv) .....	115

## S

Sales Brochure - 1949-1954.....	18-24
---------------------------------	-------

### SCRIPTS

BelAir.....	37
Chevrolet (1954 Trunk) .....	37
Chevrolet (Dash) .....	37
Deluxe.....	37
Powerglide .....	37
Seat Belts.....	74
Seat Braces (Front).....	74
Seat Cushion Padding.....	90
Seat Knob (1949-52) .....	61
Service Bulletins - 1949-1954.....	20, 23, 24
Shackle Bushings .....	144
Shift Box Shaft Rubber Boot.....	126

Shift Knobs (1949-54) .....	56
Shift Knobs (Custom).....	127
Shift Lever Bushings.....	126
Shift Lever Retainer Kit (1949-52) .....	58
Shift Rod Grommet.....	127
Shirts .....	5
Shocks .....	143
Shock Bracket (Front).....	143
Shock Bumpers.....	143
Shop Manual.....	18, 19, 23, 24
Side Molding Clip Kits .....	46, 47
Side Window Bumper (HT/Conv) .....	111, 112
Sill Plate Tag .....	70
Sound Control Kits.....	150
Sound Control Kits (Hood).....	150

### SPARE TIRE

Cover .....	97
Well.....	154
Spark Plugs.....	125
Spark Plug Wires.....	125
Speedometer Cable .....	126
Speedometer Glass (1949-50).....	61
Splash Pan Anti Rattle Seal.....	48
Spray Adhesives.....	66, 97

### SPRING

Flange .....	144
Flange Bolt .....	144
Shackle.....	144

### STARTER

Motor Brush Band .....	125
Rebuild Kit.....	125
Solenoid .....	125
Steering Column Bearing (Upper).....	57
Steering Column Seals .....	145, 146
Steering Wheels.....	57

### SUNVISOR

(Inside).....	64
Bracket (Outside).....	115
End Clips (Inside).....	64
End Bracket (Sedan) .....	115

### SUSPENSION (FRONT)

Front Coil Spring .....	143
Grease Fittings.....	143
Idler Arm Pin Kit .....	142
Inner Tie Rod End .....	142
King Pins .....	142
Outer Tie Rod End .....	142
Pass. Side Tie Rod .....	142
Rubber Bushing .....	143
Stabilizer Bar Ends .....	143
Steering Rod Connecting Seal .....	143
Suspension Bumpers.....	143
Sway Bar Bushing .....	143
Tie Rod End Boot.....	142
Tie Rod End Clamp.....	142
Upper & Lower Inner Pins.....	142
Upper & Lower Outer Pins.....	142

### SUSPENSION (REAR)

Leaf Springs.....	144
Shackle Bushings .....	144
Spring Flange .....	144
Spring Flange Bolt .....	144
Spring Shackle.....	144
U Bolts.....	144

## T

Tack Strip .....	64
Tail Light Bezels .....	31-34
Tail Light Divider 1954 .....	35
Tail Light Gaskets.....	31-34
Tail Light Lens - 1949-1954 .....	31-34
Tail Pans (1949-52).....	158
Tail Pans (1953-54).....	161
Tail Pipe Hanger .....	153
Thermostat.....	135
Thermostat Gaskets .....	135
Tissue Dispenser .....	60
Toe Boards .....	155
Tools .....	163
Traffic Light Viewer.....	60
<b>TRANSMISSION</b>	
3 Speed Floor Shift .....	127
Cooler Lines (Powerglide).....	126
Mount.....	127
Rebuild Kit.....	127
Shift Lever Knobs.....	56
Tunnel.....	157
<b>TRUNK CARDBOARDS</b>	
Carpet Covered (All Models).....	96
Replacement (All Models).....	96
<b>TRUNK CARPET</b> .....	97
<b>TRUNK GROMMETS</b>	
Floor Pan Plug .....	98, 99
Gas Door Grommet.....	98, 99
Rear Bumper to	
Gravel Pan Seal.....	98, 99
Indent Plug.....	98, 99
License Light Wire - Gravel Pan....	98, 99
License Light Wire - Trunk Floor....	98, 99
Rear License Plate .....	98, 99
Sending Wire.....	98, 99
Spare Tire Plug .....	98, 99
Trunk Lid Grommet.....	98, 99
Trunk Kit - Deluxe.....	99
Trunk Lock and Retainer .....	164
Trunk Lid Inserts (Inner).....	97
Trunk Mat.....	99
<b>TRUNK WEATHERSTRIP</b>	
Correct.....	97
Universal.....	97
Trunk Wings (1950).....	37
Tune-up Kit .....	125
<b>TURN SIGNAL</b>	
Flasher (6 V) .....	141
Housing Wedge.....	58
Switch .....	58
U Bolt (Rear Spring).....	144
Under Deck Lid Repair Panel	
(Metal).....	158, 160, 161
<b>UNIVERSAL JOINT</b>	
Clip & Nut Set.....	126
Gasket Set .....	126
Upper Door Glass Adjustable Stops	
(HT/Conv) .....	113, 114
Upper Steering Column Bearing .....	57

## V

Vacuum Advance.....	125
<b>VACUUM LINE</b>	
Transmission (Powerglide).....	124
Wiper Motor.....	117
Valve Stems and Caps.....	39
<b>VALVE COVER</b>	
Chrome Cover/Side Pan .....	124
Grommets.....	124
Nut Kit .....	124
Ventshades .....	103
<b>VENT WINDOW</b>	
Breezies .....	40
Glass Setting Rubber.....	111-114
Handle (1949-52).....	110
Rivet (Sedan).....	111, 112
Vertical Seal (HT/Conv).....	113, 114
Vertical Seal (Sedan).....	111, 112
Weatherstrip (HT/Conv) .....	113, 114
Weatherstrip (Sedan).....	111, 112
Voltage Regulator (6 V).....	125

## W

Water Neck (Chrome).....	136
Water Pump and Gasket .....	136
Weatherstrip Adhesive .....	94, 95
<b>WHEEL BEARINGS</b>	
Front .....	128
Rear.....	128
Grease Seal.....	128
Wheel Covers (All Models).....	38
Centers (1954) .....	38
Custom .....	15
Wheel Cylinders.....	134
Wheel Cylinder Rebuild Kit .....	134
Wheel Opening Repair Panel .....	156, 160
Wheel Studs .....	39
Wheel Trim Rings.....	38
Wheel Well Access Plug.....	154
Windlace (All Models).....	64, 65
Window Channel Kits (All Models).....	108, 109
Window Glass (Side - All Models).....	102, 104
Window Glass Tracks .....	109, 110
<b>WINDOW RUBBER</b>	
Rear Window .....	107
Windshield .....	106

## WINDOW STOPS IN DOOR

HT/Conv.....	111, 112
Sedan.....	109, 110
Window Crank Handles .....	62
Window Frames (Htp.Conv.) .....	105
Window Regulator Grommet ('49-54) ..	111
Window Regulator	
Roller Kit.....	111-114
<b>WINDOW WIPER</b>	
Arms.....	117
Blades.....	117
Windshield Wiper Vacuum Hose ...	117
Windshield .....	103
Windshield Center Divider Nut &	
Bolt Kit (1949-52).....	103
Windshield (Rear) .....	105
Windshield Washer Nozzles .....	117
Windshield Wiper Transmission Clip &	
Spring (1949-52).....	117
Wiper Motor (6V, 12V) .....	117
<b>WIRING</b>	
Crimper.....	163
Harnesses .....	138, 139
Junction Block (Headlight) .....	141

**ORDERING  
AND  
SHIPPING  
INFORMATION  
FOUND ON  
PAGE 4**

**DID YOU  
KNOW...**

Our first newsletter was published March 1, 1986. It was 4 pages, including the cover page. It featured 2 cars, a 1953 150 Series 4-Door Sedan and a 1953 210 Series Sport Coupe.



# *Quick Reference Guide gpj*

# SHOP/GARAGE DECALS



Blue, white and yellow.

5 1/2" ORDER #229

**\$5<sup>00</sup>**

12" ORDER #232

**\$7<sup>00</sup>**

Shop Garage Decals are  
5 1/2" and 12"  
in diameter.



Red, blue and yellow.

5 1/2" ORDER #228

**\$5<sup>00</sup>**

12" ORDER #234

**\$7<sup>00</sup>**



Red, white, blue and yellow.

5 1/2" ORDER #230

**\$5<sup>00</sup>**

12" ORDER #233

**\$7<sup>00</sup>**



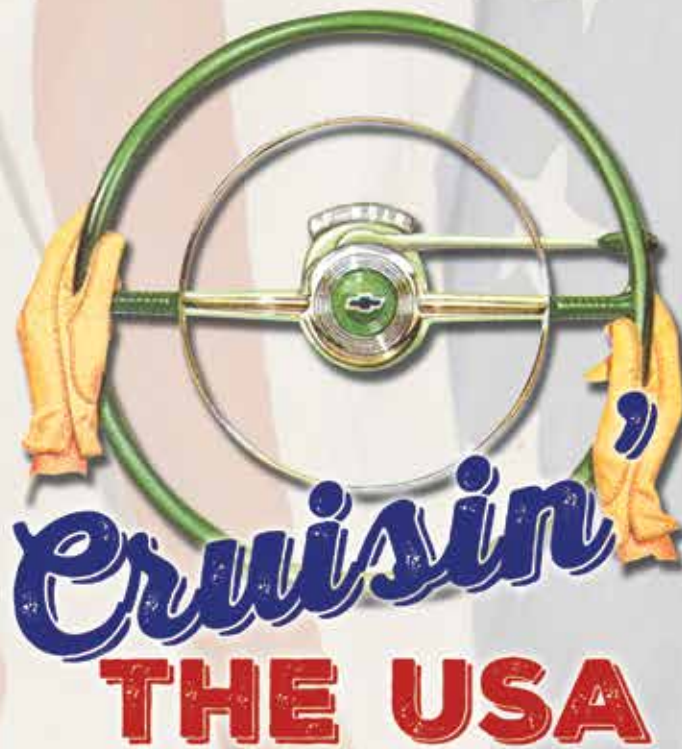

# *Cruisin'* **THE USA**



*The National Chevy Association™*



*Dedicated to the pleasure,  
pride and preservation of  
1949 - 1954 Chevrolets*

947 ARCADE  
ST. PAUL, MN 55106  
(651) 778-9522  
FAX 1-800-785-5354  
[www.nationalchevyassoc.com](http://www.nationalchevyassoc.com)  
[www.49-54nca.com](http://www.49-54nca.com)

# FREQUENTLY ASKED QUESTIONS

## **Q. Where are you located?**

A. We are located at 947 Arcade Street, Saint Paul, MN 55106

## **Q. What are your hours of business?**

A. We are open Monday- Friday 8:30-5 p.m. Central Standard Time.

## **Q. Do you have to be a member to order?**

A. No, you do not. Anyone can order parts from us.

## **Q. Do I need to have the part #'s to order?**

A. Yes, we do prefer for you to give us the part #'s for your order. This will ensure that you get exactly what you want and will help avoid costly mistakes. Part #'s can be found in the catalog and on our website at [www.nationalchevyassoc.com](http://www.nationalchevyassoc.com).

## **Q. How much does shipping cost?**

A. We have a minimum shipping cost of \$12.50 on all orders with a sub-total of \$105.00 or less. Any orders over \$105.00 shipping will cost 12% of the sub-total. Within the continental U.S. **\*\*PLEASE NOTE THAT SOME ORDERS REQUIRE ADDITIONAL SHIPPING DUE TO SIZE AND WEIGHT.**

## **Q. How do you ship?**

A. We use UPS and FedEx for the majority of orders, however, for orders in MN, WI, ND, SD, IA and IL we use Spee-Dee Delivery.

## **Q. How long does it take to ship my order?**

A. Most orders usually ship out within two business days. Some exceptions apply.

## **Q. Is there tracking for my order?**

A. Yes, if the order is placed online you should receive tracking information from UPS or FedEx once the order has been shipped. If you place your order over the phone, please provide us with your email address and we can send tracking information.

## **Q. I sent an email and have not gotten a reply**

A. We get a lot of emails on a daily basis and can not get around to replying to them all. If you have a question or concern, it's best to call us and we will be happy to help you.

## **Q. Do you ship internationally?**

A. Yes we do. Please call us or email us and we will be happy to assist. [info@nationalchevyassoc.com](mailto:info@nationalchevyassoc.com)

## **Q. How do I return an item?**

A. Send the item(s) back within 30 days with a copy of your invoice and a reason for the return. All parts must be in the original package in resalable condition. Please allow a few days for your refund to be processed.



# MAKE YOUR NEW INTERIOR KIT POP! WITH THESE UPGRADES



## NO STAINLESS? NO PROBLEM!!

- Add stylish pleats on your panels
- Available on all kits!

**\$169<sup>00</sup>**



## COLOR PIPING

A subtle, but nice addition to any kit

**\$149<sup>00</sup>**



## PLEATED PACKAGE TRAY

Like the street rod look? We got you covered!

**\$49<sup>00</sup>**



## TWO-TONE COLOR MIX!

Add stylish pleats on your panels. Available on all kits!

**\$195<sup>00</sup>**

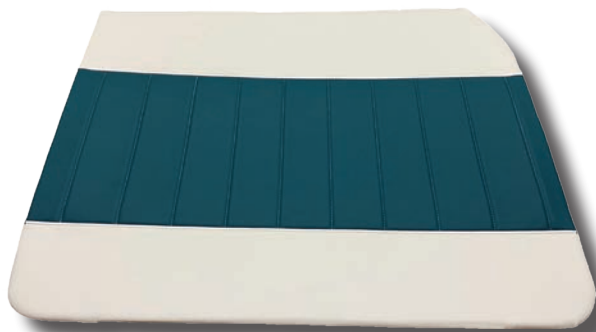

## GOT BUCKET SEATS? WE CAN HELP!

We can substitute the front seat with matching fabric that is pleated, padded and ready to go for your installer!

**NO CHARGE  
JUST LET US KNOW**

## SUN VISORS

Missing your visors? Not a problem! Nice and new visors sewn up to match perfectly with your new headliner.

ORDER #797 **\$139<sup>00</sup>**

**\*\* SEAT PADDING KITS ALSO AVAILABLE! PAGE 90 IN CATALOG**

# 10% REBATE

## SAVE \$\$

**Example...**

**Interior cost \$2100**

**Rebate \$210**

You get **\$210**  
in **FREE** parts  
on your next order

**Rebate good on all parts in catalog**

# COMPLETE INTERIOR KIT

Start at  
**\$1995**

*Comes with...*

- Front and rear seat upholstery
- Ready to install door panels
- Front and rear carpet and pad
- Headliner
- Windlace
- Matching covered kick panels
- Matching covered deck panel
- Interior sunvisors (send us your cores and we'll cover them)
- Pleated door panels available

***Our interiors offer - affordable prices with quality materials, attention to details, made with USA***

***\* NOT A UNIVERSAL FIT. Made to order for your year and model***